



Baelz Catalogue

Want to save energy? Baelz offers solutions worldwide.

Energie sparen? Baelz bietet weltweit Lösungen.

Économiser de l'énergie ? Baelz offre des solutions à l'international.

¿Ahorro de energía? Baelz ofrece soluciones en todo el mundo.

想节能吗? 贝尔茨在全球范围能提供解决方案。



WANT TO SAVE ENERGY? BAE LZ OFFERS SOLUTIONS WORLDWIDE.	4
1. VALVES	6
1.1 Product Identification - Valves.....	6
1.2 Technical Specifications of Control Valves.....	7
1.3 Noise Reduction.....	10
1.4 2-Way Control Valves.....	12
1.5 Control valves requiring no auxiliary power.....	43
1.6 3-Way Control Valves.....	46
1.7 Table of Kvs values for 2-way and 3-way control valves.....	68
1.8 Control elements, solenoid valves, accessories.....	69
2. EJECTORS	76
2.1 Ejectors - Product identification.....	76
2.2 Ejectors - Range of products.....	77
3. ACTUATORS	93
3.1 Linear Pneumatic Diaphragm Actuators.....	93
3.2 Accessories for Pneumatic Actuators.....	102
3.3 Electric Actuators - Range of products and product identification.....	107
3.4 Built-in controllers for electric actuators.....	126
4. CONTROLLERS, CONTROL TECHNOLOGY AND ANCILLARY EQUIPMENT	129
4.1 Controllers, control technology and ancillary equipment - product overview.....	129
4.2 Overview of microprocessor controllers - closed loop.....	131
4.3 Control application examples.....	132
4.4 Ancillary equipment.....	150
5. HEAT EXCHANGERS AND TANKS	163
5.1 Heat exchangers and tanks - product overview.....	164

6. SYSTEMS, STATIONS AND ABSORPTION CHILLERS	182
6.1 Steam and condensate - Baelz-thermodynamic®	183
6.1.1 Steam and condensate - selection table, planning advice and inquiry	186
6.1.2 Steam Terminal® – Steam heat transfer stations	187
6.1.3 Steam Terminal® Modulo	189
6.1.4 Clean steam generator compact stations	190
6.1.5 Condensate Terminal®	192
6.1.6 Connection to a condensate system	194
6.2 Ejector technology - the basics	195
6.2.1 Steam ejector technology - Baelz-vapordynamic®	196
6.2.2 Steam ejector technology - Superheated steam cooling & pressure reduction	199
6.2.3 Steam ejector technology - Mixing ejectors	201
6.3 Water ejector technology - Baelz-hydrodynamic®	202
6.4 Cooling - Absorption chillers	205
7. SENSORS - PRODUCT OVERVIEW	212
8. THERMOSTATS, CONTACTORS AND PUMPS - PRODUCT OVERVIEW	223
9. FITTINGS - PRODUCT OVERVIEW	237
10. SPARE PARTS - PRODUCT OVERVIEW	295
11.1 Max. pressures and temperatures according to DIN EN 1092	312
11. BAE LZ PRESSURE EQUIPMENT: PRESSURE AND TEMPERATURE LIMITS OF MATERIALS	312
11.2 Baelz Pressure Equipment: Materials used According to Baelz Type	314
12. SUMMARY OF STANDARDS AND MATERIALS	315

Key to symbols:



steam



liquids



thermal oil



gases



Want to save energy? Baelz offers solutions worldwide.

Baelz is a family-owned enterprise with over a century of tradition and experience, based in Heilbronn, Germany. Baelz technologies are geared towards innovation for the economical use of energy and resources. Thanks to our commitment to continuous development and improvement, Baelz components and products for control, heat and cold engineering are in operation worldwide.



Control Valves for Industry and Building Services

Baelz-electrodyn®

Electrically and pneumatically operated **control valves from DN15 to DN300** for water, steam, thermal oil, hot water, condensate, oxygen, nitrogen and many other media. Baelz control valves have a far superior design and long service life because they are built with decades of Baelz experience as developer of thermal systems, making Baelz a competent partner when it comes to selecting and designing valve housings and drives for specific applications



Controlled Ejectors for Fluids

Baelz-hydrodynamic® Jetomat®

Baelz ejectors offer durability and excellent value for money with long service lives and low maintenance. Installations are reliable, energy-economical and cost-effective to run.

Controlled Ejectors for Vapor

Baelz-vapordynamic®

Fields of application for baelz 590 controlled thermocompressor / ejector for vapor include recirculation, compression and pressure reduction in rotary drum dryers or compression of exhaust vapor.



Heat Exchangers

Baelz-thermodynamic®

Baelz offers a wide range of heat exchangers for all types of plant in HVAC, district heating and industry. Suitable heat transfer media are steam, heating and hot water and thermal oil.

Our in-house production in Germany enables us to manufacture individual, customized solutions using unique modular systems. We supply heat exchangers, steam generators with straight, U-shaped and spiral tubing or fixed tube bundles in either vertical or horizontal design.





System Solutions - Water

Baelz-hydrodynamic®

System solutions can be individual components or compact units, pre-assembled and ready-wired to suit customer requirements. They are ready to operate upon delivery, eliminating time-consuming installation work on site and saving money for the customer.

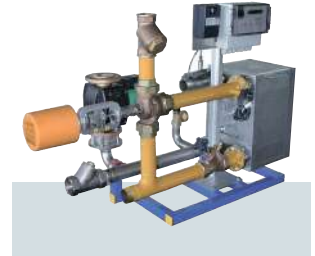

System Solutions - Steam

Baelz-thermodynamic® Steam Terminal®

Wherever steam is used, there are potential energy savings which can be realized by our versatile system solutions. These are fully piped and wired, insulated and skid-mounted as required.



System Solutions - Absorption Refrigeration

Baelz-absorpdynamic®

These are medium-range compact and energy efficient heat-operated refrigeration systems. Possible sources of heat are power plants, local and district heating networks, solar-powered systems or industrial waste heat. The use of low feed temperatures from 55°C enables the use of excess heat. Available with power outputs of up to 500 kW.

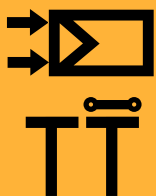

Closed-Loop Systems

Baelz-electrodyn® Pilot®

Baelz closed-loop controllers with internally developed hardware and software are designed for intelligent control and automation in industry and building services, optimizing efficiency in the generation, consumption and conversion of energy. All Baelz Touchpilot controllers are touch screen operated.



Central Control Systems

Baelz-electrodyn®

The WinBAS universal software package for Baelz building and plant control technology is flexible, adaptable and modular. It offers all the options necessary for comprehensive automation concepts in buildings and industry.

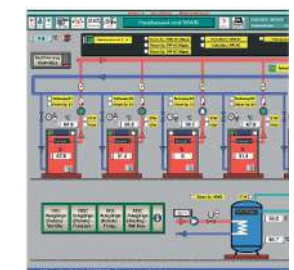



1.1 Product Identification - Valves

Example of identification for ordering: **Baelz 340-2-B-TK-DN50-PN16-Kvs10-Skr-spheroid ductile iron**

Baelz - 340-2 - B - TK - DN50 - PN16 - Kvs10 - Skr - spheroid iron

Series									
	185								
	192								
	334								
	340-2								
	344								
	356								
	358 / 359								
	360								
	365								
	335								
	342-2								
	347-2								
	353 / 354								
	367								
Valve options									
Universal valve. max. 240°C			B / BB						
Valve with cooling tube. max. 350°C			K / BK / BBK						
Valve made of stainless steel			ES / VA						
Plug options and spindle sealing									
Balanced plug				EMF					
Soft seal				TK					
High-temperature type				EMF-K					
With bellows seal				SS					
Balanced, piston plug in a fixed cage / with perforated cage				C / CC					
Nominal diameter									
					DN				
Nominal pressure									
						PN			
Metric flow factor (Kvs)									
							Kvs		
Additional plug options									
Cage plug								LK	
Reduced Kvs value								Skr	
Housing material									
									Spheroid ductile iron
									Steel
									Cast steel
									Stainless steel
									Heat-resistant steel
									Cast brass
									Red brass

Examples of plug designs and control characteristics

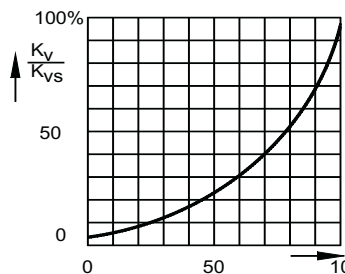

Equal percentage

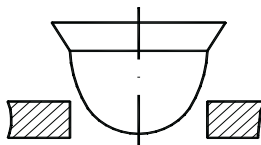

baelz 356

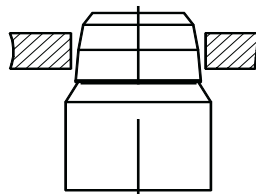

baelz 340-2

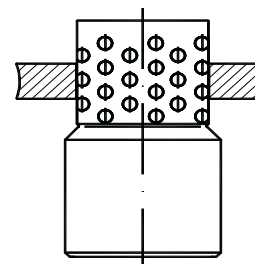

baelz 340-2-LK

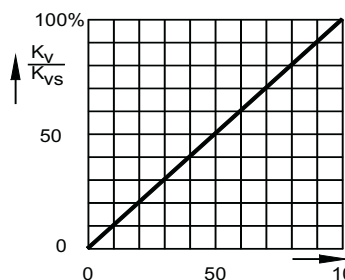

Linear

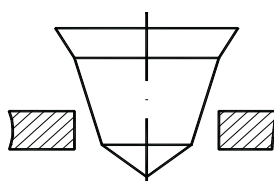

baelz 356

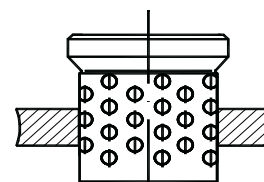

baelz 356-LK

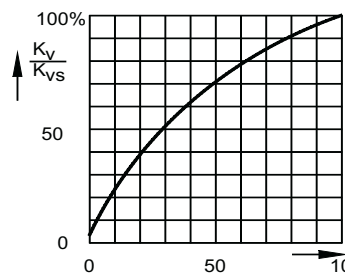

Open/close

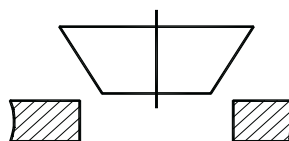

baelz 340-2, baelz 356

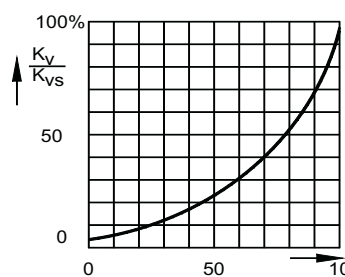

Equal percentage

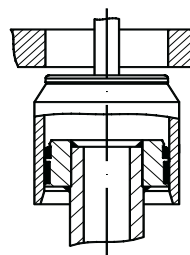

baelz 340-2-B-EM

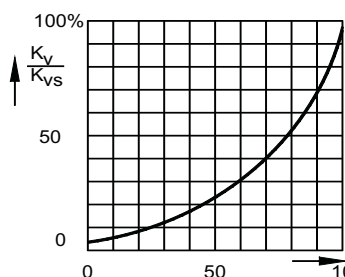

Equal percentage

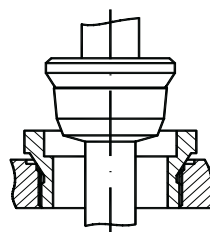

baelz 346-EMB
(on request)

[Inquiry form](#)

Baelz Surface Treatments for Valves and Ejectors		
	Standard coating	Enhanced corrosion protection (surcharge) Order-No.: MP-KORROSIONSSCHUTZ
Product for surface treatment	High-temperature-resistant aluminium paint	Gray zinc-rich paint + topcoat "white aluminium"
Description / Applications	Oil-free synthetic resin aluminium paint as a protective coating for hot surfaces (boilers, heating systems etc.)	Coating based on specially modified synthetic resins for chemical, heat and corrosion resistance in machine and plant construction.
Properties	Heat and weather-resistant coating. Weathering can affect the mechanical resistance of the coating. Not resistant to fats, oils, mineral oils, benzines, salts, alcoholic liquids, acids and alkalis.	Corrosion protection category 3 according to DIN EN ISO 12944 . Good adhesion to steel. Resistant to corrosive and aggressive substances.
Temperature resistance	In dry, indoor spaces up to 500 °C. At 500 °C no silicone constituents are released.	Resistant to sustained temperature 200 °C Short-term resistant to a temperature of 250°C
Color	Metallic aluminium gloss	Metallic aluminium gloss

Fu/SB = spring below / **FSR** = fail-safe retracts → in case of air/power supply failure actuator retracts spindle
Fo/SA = spring above / **FSE** = fail-safe extends → in case of air/power supply failure actuator extends spindle

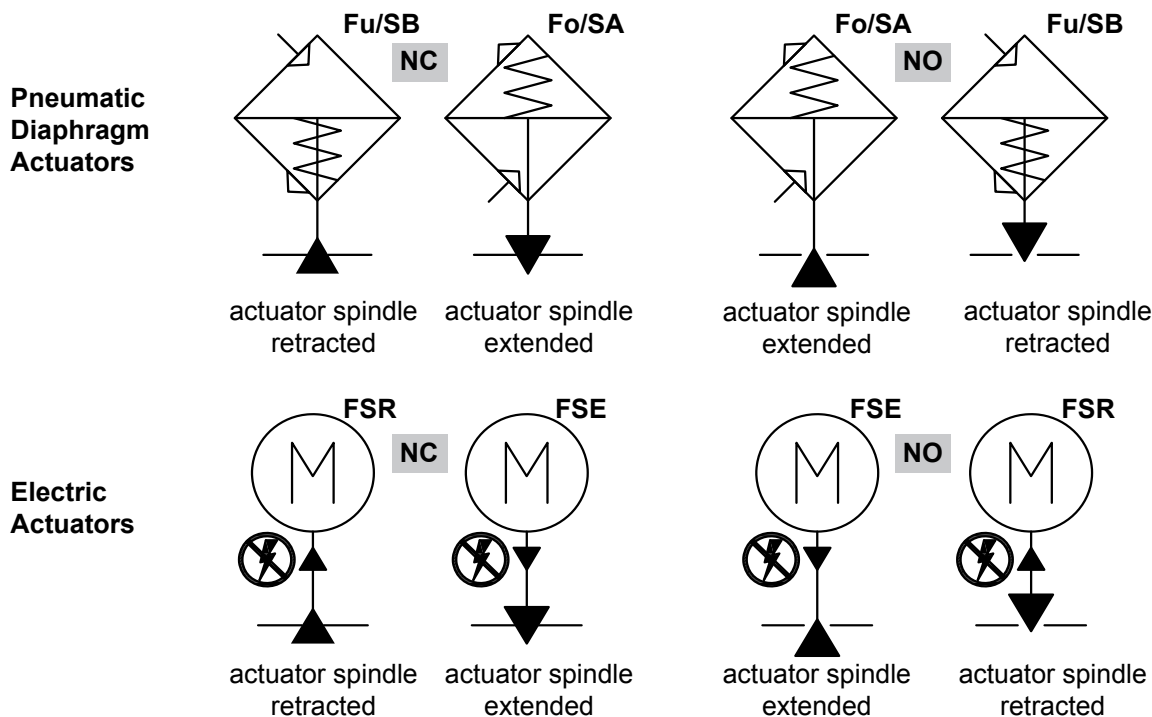

2-way valves have two possible fail-safe positions:

spindle retracted = valve closed and spindle extended = valve closed.

Direction of action **NC** (normally closed): air / power failure → valve **closed**
 Direction of action **NO** (normally open): air / power failure → valve **open**

Fail-Safe Positions of Baelz Valves and Ejectors in Case of Air / Power Supply Failure dependent upon the configuration of the actuator			
Air / power supply failure: valve closed (NC) Air / power supply failure: valve open (NO)		Air/power supply failure: Way A-AB closed*	
2-way valves SB / FSR	2-way valves SA / FSE	all ejectors SA / FSE	all Baelz 3-Way valves SB / FSR
actuator spindle retracted			
NC	NO	NO	NC
actuator spindle extended			
NO	NC	NC	NO
340-2	340-2-AI	471	335
334	185	472	342-2
365	344	475	347-2
	346	480	347-2-AI
	356	485	354
	358	590	367
	359	591	
	360		

*If the B-AB way of 3-way valves is to be closed in case of air/power supply failure:
 To reverse direction of action → Select an Fo/SA actuator (pneumatic) / FSE actuator (electric).

Examples of solutions for noise reduction:

1. Cage plug LK

The LK cage plug is available for all valve series and is effective against noise and cavitation. The parabolic plug is replaced by the cage plug, which changes the direction of flow and divides it into several currents through smaller openings.

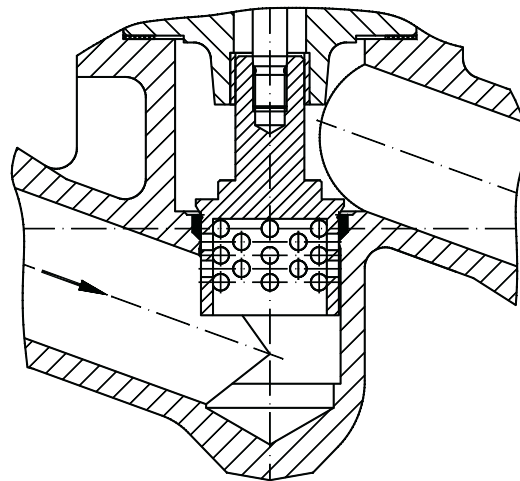

Cage plug

2. Valve with baelz 6250 perforated plate for noise reduction

The baelz 6250 perforated plate protects the valve against damage caused by an excessive pressure drop and has a noise-damping effect. The perforated plate is connected downstream from the valve and absorbs most of the pressure drop. Thus, the cheap perforated plate is "sacrificed" to prevent damage to the expensive valve.

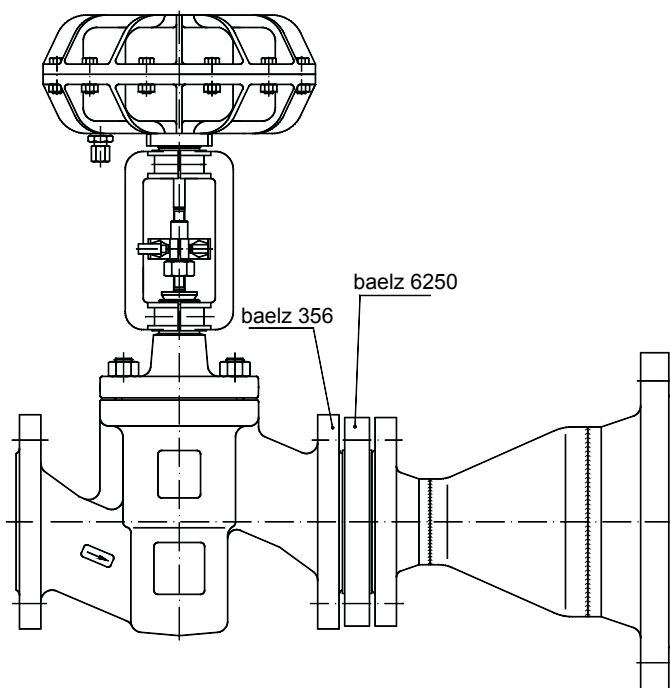

Example of mounting a baelz 6250 noise-damping perforated plate in the pipeline

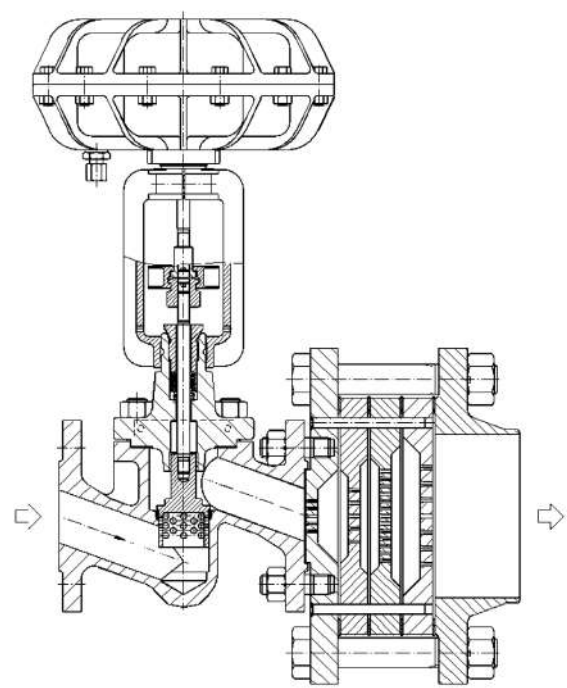

Example of mounting several baelz 6250 noise-damping perforated plates in the pipeline

3. Noise damping and prevention of cavitation with balanced and unbalanced plugs

Unbalanced plug

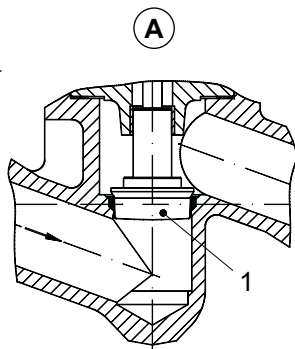

1. Parabolic plug

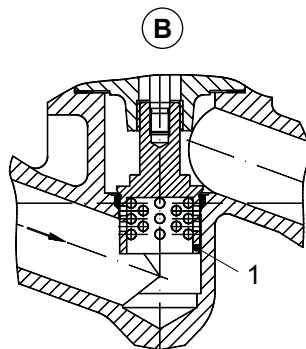

1. Cage plug

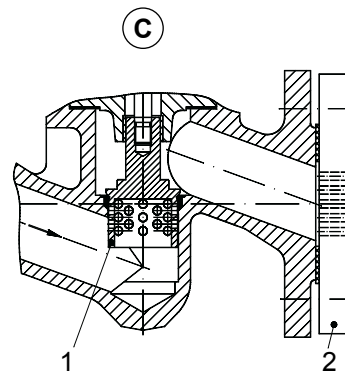

1. Cage plug
2. Noise damper (perforated disk)

Balanced pressure plug

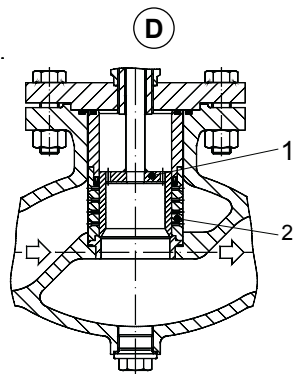

1. Plug
2. Seat

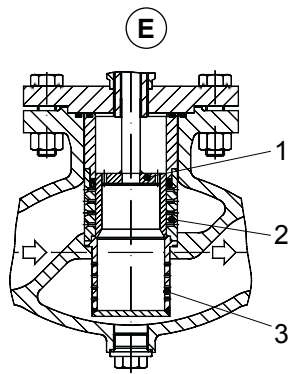

1. Plug
2. Seat
3. Cage

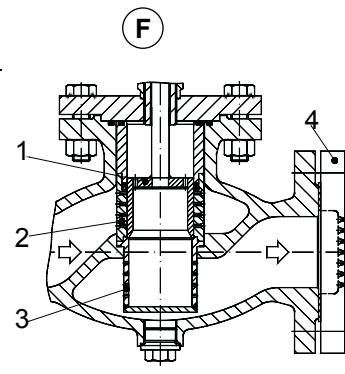

1. Plug
2. Seat
3. Cage
4. Noise damper

Determination of the noise level and cavitation for control valves

Application for hot water (and condensate)

Temperature $T_v = 120^\circ\text{C}$ Inlet pressure $P_1 = 6$ bar absolute outlet pressure $P_2 = 3$ bar absolute saturation pressure $P_v = 2$ bar absolute vapor pressure at temperature T_v				150 °C 16 bar abs. 5 bar abs. 4.8 bar abs.				
Fig.	A	B	D	A	B	C	D	E
Cavitation	Yes	No	No	Yes	Yes	No	Yes	No
Noise reduction dB	0	30	30	0	6	31	20	31
Compared to c XF*	<0.2	$0.2 < X_f < 0.5$	$0.5 < X_f < 0.75$	<0.2	$0.2 < X_f < 0.5$	$0.2 < X_f < 0.5$	$0.2 < X_f < 0.5$	$0.75 < X_f$

* $X_f =$ ratio of the differential pressure for liquids $X_f = P_1 - P_2 / P_1 - P_v$

Application for steam

Inlet pressure Outlet pressure						
Fig.	A	B	C	D	E	F
Noise reduction dB (A) compared to Fig. A. parabolic plug	0	7	11-21*	8	12	16-23*

*1-5 perforated disks

page 14

baelz 185



- DN 15
- PN 40
- Flanged connection
- Housing 1.4021
- max. 350°C
- For low flow volumes
- Built-in strainer
- V-rings in PFTE
- Cooling tube
- Bellows seal
- Water, hot water, steam



page 17

baelz 334



- 1/2"– 1 1/2" / DN 15-40
- PN 16 / 25
- External thread/for welding
- Housing CC491K - CuSn5Zn5Pb5-C
- max. 150°C
- V-rings in PFTE
- Water, hot water, steam



page 20

baelz 340 & 340-2-B baelz 340 & 340-2BB baelz 340 & 340-2-B-EMF baelz 340 & 340-2BB-EMF



- DN 15-300
- PN 16 / 25 / 40
- Flanged connection
- Housing 5.3103 / 1.0619 / 1.4313
- max. 240°C
- Balanced valve
- Cage plug
- Reduced Kvs
- V-rings in PFTE
- Liquids, water, steam, gases



page 20

baelz 340 & 340-2-BK-SS baelz 340 & 340-2BBK-SS



- DN15-125 / 150-300
- PN 16 / 25 / 40
- Flanged connection
- Housing 5.3103 / 1.0619
- max. 350°C
- Cage plug
- Reduced Kvs
- V-rings in PFTE
- Cooling tube
- Bellows seal
- Liquids, water, thermal oil, steam, gases



page 26

baelz 344



- DN50-150
- PN 16 / 25 / 40
- Flanged connection
- Housing 1.4408
- max. 350°C
- Balanced valve
- Cage plug
- V-rings in PFTE
- Cooling tube
- Bellows seal
- Liquids, water, thermal oil, steam, gases



page 29

baelz 356-1 & 356-2



- DN 15-65
- PN 16 / 25 / 40
- Flanged connection
- Housing 1.0460 / 1.4571 / 1.0619
- max. 240°C
- Cage plug
- Reduced Kvs
- V-rings in PFTE
- Liquids, water, steam, gases



page 29

baelz 356-1 & 356-2-K-SS



- DN 15-65
- PN 16 / 25 / 40
- Flanged connection
- Housing 1.0460 / 1.4571 / 1.0619
- max. >350°C
- Cage plug
- Reduced Kvs
- V-rings in PFTE
- Cooling tube
- Bellows seal
- Liquids, water, thermal oil, steam, gases



page 33

baelz 358-K / 359-K



- DN 15-125
- PN 63 / 100 / 160
- Flanged connection
- Housing 358-K 1.7335 / 1.7357
- Housing 359-K 1.0460 / 1.0619+N
- max. >350°C
- Cage plug
- Reduced Kvs
- V-rings in PFTE
- Cooling tube
- Bellows seal
- Liquids, water, steam, gases



page 37

baelz 360-EM-C baelz 360-EM-CC



- DN 32-150
- PN 40
- Flanged connection
- Housing 1.0619
- max. 315°C
- Balanced valve
- Additional perforated cage
- V-rings in PFTE
- Cooling tube
- Liquids, water, steam, gases



page 40

baelz 365 & 365-2-2-A3 baelz 365 & 365-2-A3 baelz 365-2-K-SS-A3 baelz 365-K-SS-A3



- 1/2" - 10" / DN 15-250
- ANSI 300
- Flanged connection
- Housing SA216WCB - 1.0619
- max. 400°C
- Cooling tube
- Bellows seal
- Liquids, water, thermal oil, steam, gases



page 43

baelz 192



- DN 15-125
- PN 16 / 40
- Flanged connection
- Housing 5.3103 / 1.0619
- max. 240°C
- Cage plug
- Pilot valve
- Solenoid valve





baelz 185

DESCRIPTION

The baelz 185 is a versatile DN 15 microflow control valve for low flow rates with integrated strainer and stainless steel housing.

Provided with 6 holes („VA“ and „VU“, page 15) with G1/2" thread, for connecting accessories:

- Pneumatic or electric actuator
- Solenoid valve
- Manual isolating valve
- Direct-acting pilot valve
- Safety valve
- Pressure sensor or temperature sensor
- Drain valve or ball valve

TECHNICAL SPECIFICATIONS

Housing material - stainless steel 1.4021

Connection type: flange EN 1092-2; EN 1092-1 Shapes D / E / F on request.

Plug type: Tapered plug, PTFE soft seal plug. Plug and seat replaceable.

Additional options:

- baelz 260st single or double manual valves for filter cleaning
- Plug soft seal

Working fluids: water, hot water, steam

Leakage class (EN 1349)
metal-to-metal seal: 0.004% Kvs (better than class IV)
with PTFE plug: 0.001% Kvs (better than class VI)

Valve	Stroke	Spindle diameter
DN 15, PN 40	16 mm	10 mm

Options	Special features	T max. / P max.	Designation
Plug	Stainless steel (standard)	240 °C / 40 bar ... 50 °C / 40 bar	baelz 185
	Stainless steel + PTFE (PTFE)	240 °C / 40 bar ... 50 °C / 40 bar	MP185-TK-15
Spindle seal	V-rings in PTFE (standard)	240 °C / 40 bar ... 50 °C / 40 bar	baelz 185
	Cooling tube	350 °C / 34 bar ... 50 °C / 40 bar	MP185-K
Housing	Locking screws made of stainless steel 1.4401 (Standard: galvanized steel)	240 °C / 40 bar ... 50 °C / 40 bar	MP185-VA-15
Flange	EN 1092-1 Shapes D / E / F on request	240 °C / 40 bar ... 50 °C / 40 bar	MP185-VR-15

Actuators	Identification
Pneumatic diaphragm actuator	baelz 373-P21
Electric linear actuator	baelz 373-E07 / 373-E07-OSD/OSZ
Solenoid valve	baelz 266st, baelz 265st*
Direct acting controller	baelz 206r**

* When used with the solenoid valve, the temperature is limited, see Chapter «Electric actuators»

** see Chapter «baelz 192 pilot-operated reducing valve ».

DN	Kvs value (m³/h)									
	15									
Standard	0.025	0.04	0.10	0.12	0.16	0.30	0.60	1.00	1.20	1.40
With soft seal (TK)	-									

baelz 185 DN15 dimensions and weight							
Model	BL	h1	h2	L1	L2	L3	Weight, approx. (kg)
	(mm)						
baelz 185	130	90	98.5	113.5	65	4	5.2
baelz 185-K	130	90	251	113.5	65	4	6.2
Additionally with a baelz 260st manual valve							+ 0.4
Additionally with two baelz 260st manual valves							+ 0.8

baelz 373 dimensions (mm)					
Designation	L	x	Ød	l	ØD
E07	320	145	129		
E07-OSX	354	145	129		
P11				244	160
P21				268	242

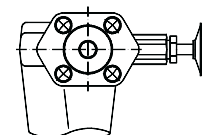

baelz 185 - 260st

baelz 185 + 206r dimensions (mm)				
L	A	C	T max	ØD max
100	450	135	110	130
200	550	165	200	130
300	650	195	300	130

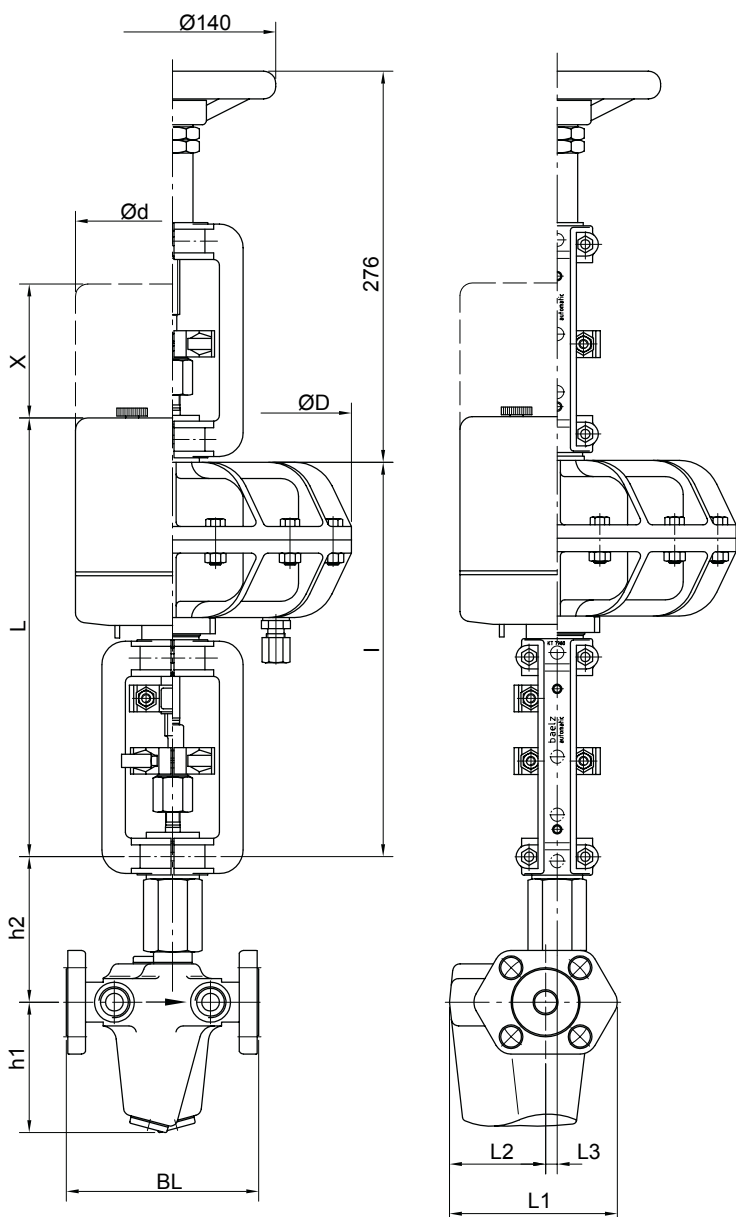

baelz 185 with pneumatic / electric actuator

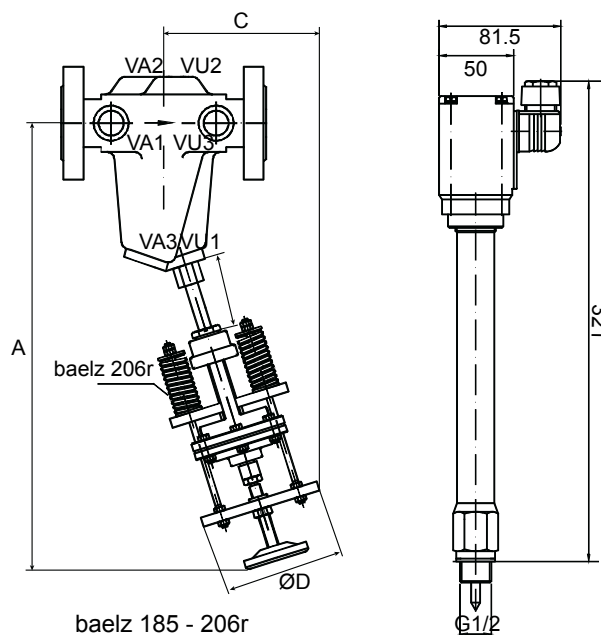

baelz 185 - 206r

baelz 265st solenoid valve

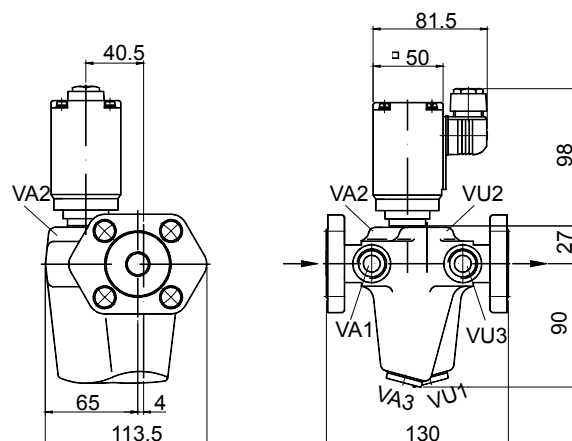

baelz 185 with baelz 266st solenoid valve

Option: baelz 185 valve with integrated manual valves baelz 260st

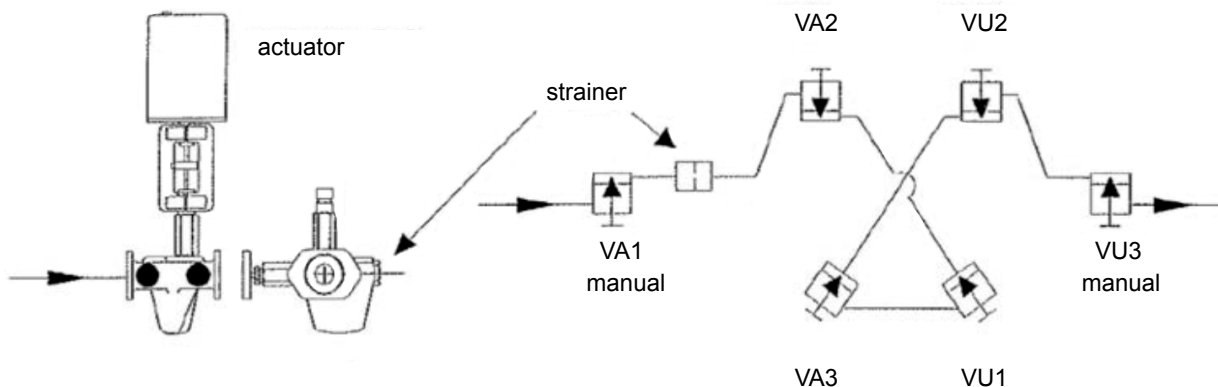

Sectional drawings of the baelz 185 plug

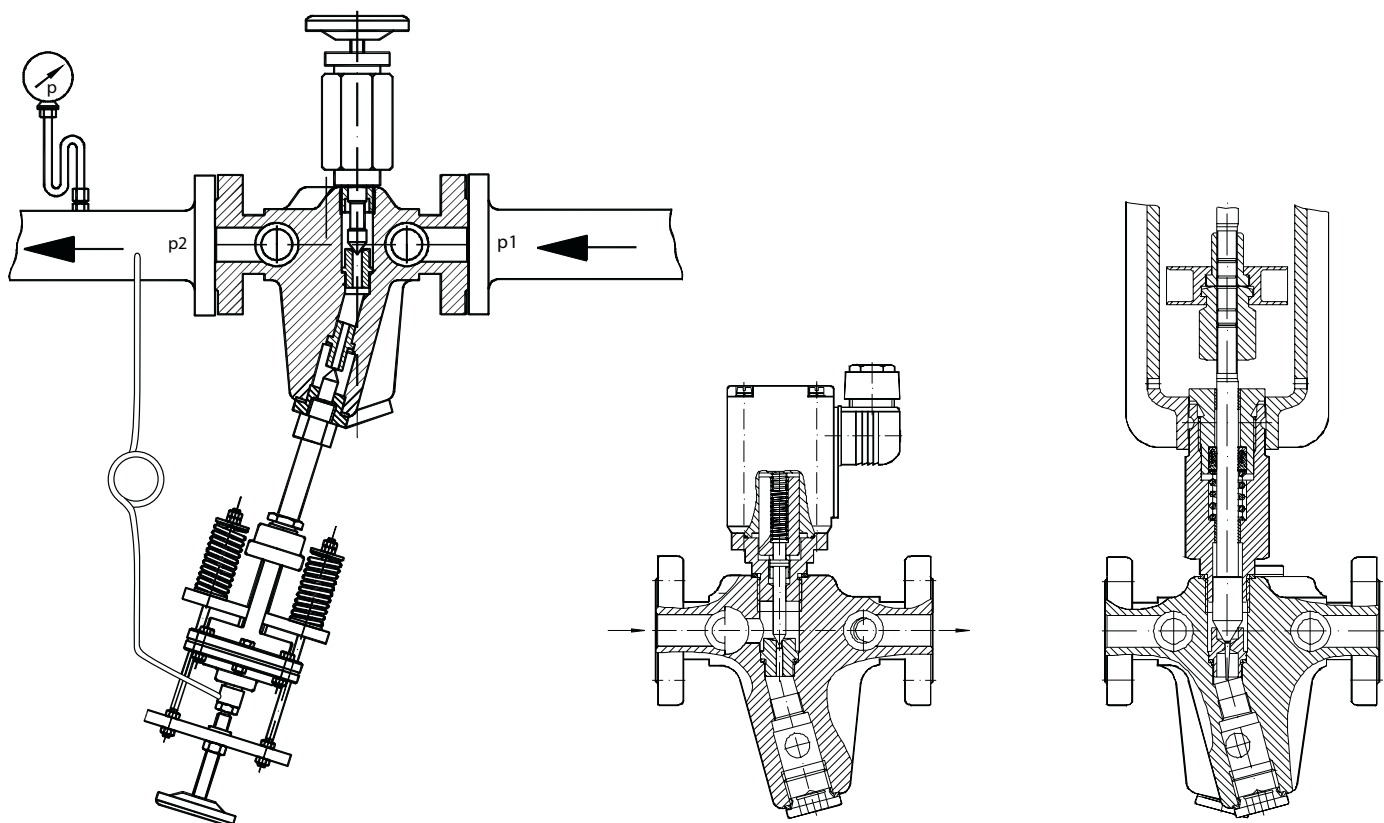

baelz 185 needle plug with 206r direct acting actuator and baelz 260st manual valve

needle plug baelz 185 with baelz 266st solenoid valve

needle plug / parabolic plug baelz 185



baelz 334

DESCRIPTION

The baelz 334 is a 2-way control valve with a red brass housing for heating, ventilation and air conditioning systems.

TECHNICAL SPECIFICATIONS

Connection type: external thread with union nut and weld-on steel sockets

Plug type: standard control plug

Control characteristic: linear

Stroke - 12 mm

Additional options:

Weld-on stainless steel sockets (ASE) or threaded brass sockets (GT)

Working fluids: water, hot water, steam

Leakage class (EN 1349)

metal-to-metal seal: 0.004% Kvs (better than class IV)

Options		Designation
Plug	Parabolic plug, slot guides (standard) stainless steel 1. 4571	baelz 334-1
Spindle seal	V-rings in PFTE (standard)	baelz 334-1
Connection	Brass union nut + steel nozzle for welding	baelz 334-1
	Brass union nut + weld-on stainless steel sockets	MP334-ASE...
	Brass union nut + threaded brass sockets	MP334-GT...

T max. (°C) / P max. (bar)	
Housing material	Red brass CC491K - CuSn5Zn5Pb5
Nominal pressure	PN 16 / 25
baelz 334-1	Water: 150 / 25
baelz 334-GT	Steam 150 / 10 ... -10 / 22
baelz 334-ASE	

Kvs value (m³/h)					
DN	15 (1/2")	20 (3/4")	25 (1")	32 (1 1/4")	40 (1 1/2")
Standard	3.5	5	9	16	16

baelz 334 dimensions and weight					
DN		BL	h1	h2	Weight, approx.
		(mm)			(kg)
1/2"	15	92	38	72	1.5
3/4"	20	95	45	72	1.7
1"	25	105	50	72	1.8
1 1/4"	32	105	58	72	2
1 1/2"	40	114	62	72	2.5

Dimensions of the baelz 373 actuators (mm)					
Designation	L	x	Ød	l	ØD
E07	320	145	129		
P11				244	160
P21				268	242

Electric actuators: baelz 373-E
 Pneumatic actuators: baelz 373-P

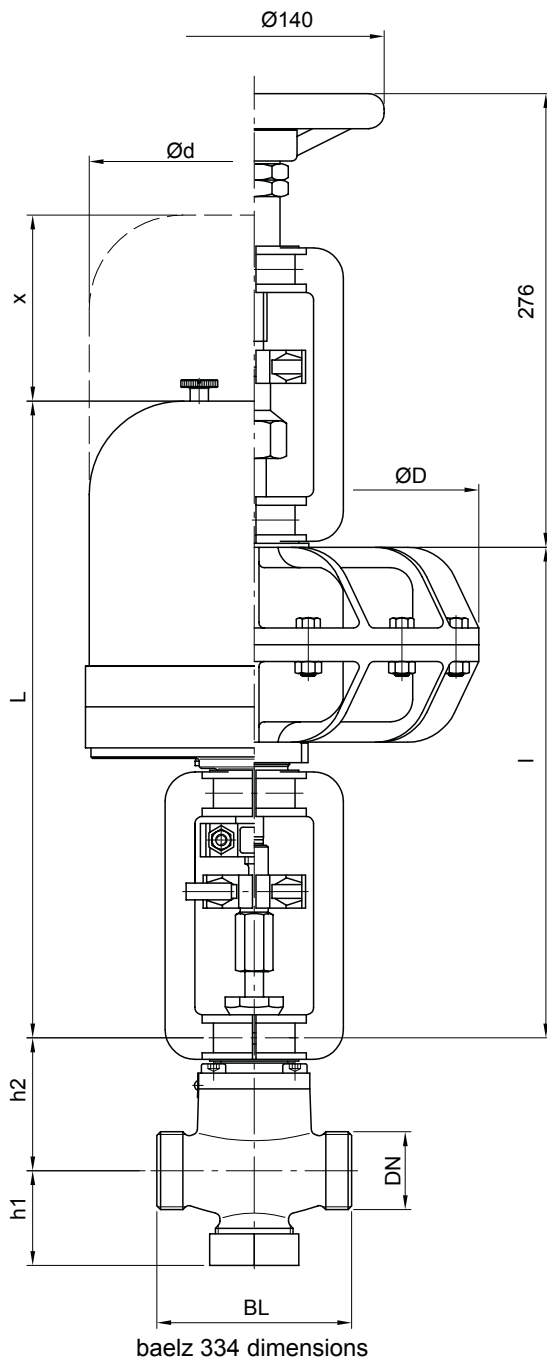

Sectional drawing of the baelz 334 plug

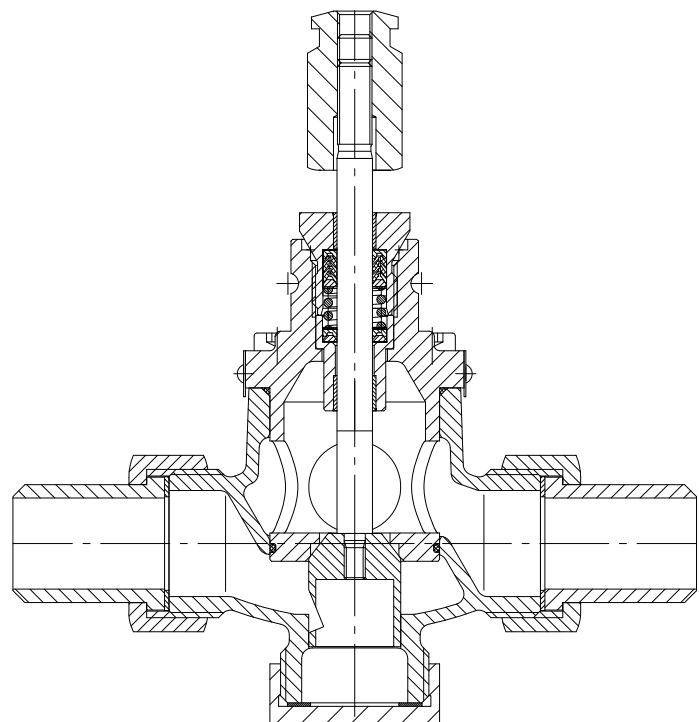

standard control plug
 baelz 334

Maximum differential pressure ΔP_{max} (bar) at which the actuator closes the valve completely
 The differential pressures specified here are limited by the nominal pressure of the housings, if this is lower.

Electric actuators. Plug closes against the flow.

Actuator baelz 373-	Power (N)	DN (mm) / maximum differential pressure ΔP_{max} (bar)														
		15	20	25	32	40	50	65	80	100	125	150	200	250	300	
E07- OSX-	700	14	14	10	5	2.5	1.2	0.3								
E07- 20-	2000	40	40	32	20	12	8	4.8	3	2	1.2					
E65- 11-	1100	25	25	16	10	6.3	3.5	1.7	0.9	0.3						
E65- 20-	2000	40	40	32	20	12	8	4.8	3	2	1.2					
E45- 40-	4000	40	40	40	40	25	16	10	6.9	4.4	2.8	1.7				
E66- 80-	8000											3.1	1.6	0.9		
E66- 150-	15000											7.1	3.8	2.3	1.5	
E88- 100-	10000							28	18	11	7.4	5	2.7	1.7	1.1	
E88- 100-	13000							37	24	15	9.8	6.7	3.7	2.3	1.5	
E88- 100-	16000							40	30	19	12	8.4	4.6	2.9	2	
E88- 300-	30000									(36)	(23)	15.3	9	5.8	3.9	
E88- 300-	35000											18.9	10.5	6.7	4.6	
E88- 300-	40000											21.7	12.1	7.7	5.3	

Pneumatic actuators (OPG) closed without compressed air. Plug closes against the flow.

Actuator baelz 373-	Power (N)	req. feed pressure (bar)	DN (mm) / maximum differential pressure ΔP_{max} (bar)													
			15	20	25	32	40	50	65	80	100	125	150	200	250	300
P11- 1	950	3.0	39.5	18.2	13.6	8.1	4.3	2.4	1.1	0.5						
P21- 3	1020	1.2	29	29	16	9.9	6.3	4.6	2.7	1.8	1	0.6				
P21- 6	2040	3.0	40	40	35	21	13.5	8.9	5.2	3.4	2.2	1.4				
P21- 12	3390	6.0	40	40	40	36	23	14	8	5	3.5	2.1				
P21- 18	4030	6.0	40	40	40	40	27	18	10	7	4.5	2.8				
P21- V6	7590	6.0	40	40	40	40	40	34	20	13	8	5				
P22- 3	1846	3.0	40	40	34.5	18.8	11	6.5	3.4	2	1.1	0.5				
P22- 6	3692	6.0	40	40	40	40	25.2	15.3	8.5	5.3	3.2	1.9				
P31- 3	2480	1.2											1.1			
P31- 6	4960	3.0											2.4			
P31- 18	10560	6.0											5.3			
P32- 6	4402	3.0												0.8		
P32- 18	8115	6.0												1.8		
P41- 3	3765	1.2											2.4	1	0.6	0.4
P41- 6	7530	3.0											5	2	1.3	0.9
P41- V6	31920	6.0											21	10.5	6.5	4.5

Pneumatic actuators (OPO) open without compressed air. Plug closes against the flow.

Actuator baelz 373-	Power (N)	req. feed pressure (bar)	DN (mm) / maximum differential pressure ΔP_{max} (bar)													
			15	20	25	32	40	50	65	80	100	125	150	200	250	300
P11- 1	2111	6.0	40	40	40	29.2	17	10.5	5.8	3.7						
		1.2	7	7	4.5	2.8	1.8	1.1	0.6	0.4						
P21- 3	1020	3.0	40	40	40	40	31	19	12	8	5	3				
		6.0	40	40	40	40	40	40	30	20	12	8				
P21- 6	2040	3.0	40	40	35	21	14	8	5.3	3.5	2.2	1.4				
		6.0	40	40	40	40	40	39	24	16	10	6				
P31- 3	2480	1.2											0.6			
		3.0											6			
		6.0											14.8			
P31- 6	4960	3.0											3			
		6.0											12			
P41- 3	3765	1.2											1.2	0.7	0.4	0.3
		3.0											12	6.8	4.3	3
		6.0											30	17	11	7.5
P41- 6	7530	3.0												5	3	2
		6.0												15	10	6



baelz 340 & 340-2

DESCRIPTION

The baelz 340 / 340-2 is a 2-way control valve in a 3-way housing for industrial applications. Several plug variants allow utilization for different control tasks.

TECHNICAL SPECIFICATIONS

Connection type: Flange EN 1092-2; EN 1092-1 Shapes D / E / F on request.

Plug type: parabolic plug, special plug, cage plug

Control characteristic: equal percentage, linear

Working fluids: liquids, gases, water, steam, thermal oil, etc.

Leakage class (EN 1349)

metal-to-metal seal: 0.004% Kvs (better than class IV)
with PTFE plug: 0.001% Kvs (better than class VI)

Stroke (mm)

DN 15 - DN 25	12
DN 32 - DN 125	22
DN 150	44
DN 200 - DN 300	66

Spindle diameter (mm)

DN 15 - DN 25	12	10
DN 32 - DN 125	22	10 (16*)
DN 150	44	22
DN 200 - DN 300	66	

** for baelz 340-2-B-EMF DN 100, DN 125

Options		Designation**
Plug	Parabolic plug (standard)	baelz 340-2-B...
	Balanced	baelz 340-2-XX-EMF
	Cage plug	MP340-LK...
	Reduced Kvs	MP340-SKr...
	With PTFE soft seal plug (max. 200°C)	MP340-TK...
Spindle seal	V-rings in PFTE standard	baelz 340-2-B...
	Cooling tube	baelz 340-2-BK...
	Cooling tube + bellows seal	baelz 340-2-BK-SS...
Flanges	Flange facing: inlet groove, outlet tongue	MP340-NF...
	Flange facing: inlet/outlet: male/female	MP340-VR...
	Flange facing: groove both sides	MP340-ALL-N...
Additional options	V-shaped seal heating (for fluids at temperatures of - 10 to - 40°C) Pmax. 20 W; 12-24 V / 110-230 V AC/DC	baelz 85950...
	Construction without silicone	MP340-Silf...

** Designation: 340-2-B up to DN 125 and for spindle Ø up to 16 mm; 340-BB from DN 150 and for spindle Ø 22 mm

Housing material	T max. (°C) / P max. (bar)		
	Spheroid ductile iron GJS-400-18-LT - 5.3103		Cast steel GP240GH - 1.0619
Nominal pressure	PN 16	PN 25	PN 40
baelz 340-2-B, 340-BB	240/12.3 ... 50/16	240/19.3 ... 50/25	-
baelz 340-2-B-EMF, 340-BB-EMF			240/30.9 ... 50/40
baelz 340-2-BK, 340-BBK	350/10.2 ... 50/16	350/16 ... 50/25	350/25.7 ... 50/40
baelz 340-2-BK-SS, 340-BBK-SS			350/25 ... 50/25
baelz 340-2-BK-EMF, 340-BBK-EMF	315/10.7...260/11.8 ... 50/16	315/16.8 ...260/18.6 ... 50/25	315/27...260/29.8 ... 50/40

Note: As we are constantly improving our products, there is more than one series of this article. When ordering spares or parts for an existing system, please state the old serial numbers and, if in doubt, contact Baelz. We'll be pleased to help.

DN	Kvs value (m³/h)													
	15	20	25	32	40	50	65	80	100	125	150	200	250	300
Standard plug (B/BB)	5.9	7.8	9.6	16	25	36	63	105	130	200	360	580	960	1340
Balanced plug (EMF)					25	36	63	105	130	200	360	580	960	1340
Balancing cage plug (EMF-LK)	-	-	-	-	20	32	50	80	100	130	250	320	-	-
Reduced Kvs (Skr)	2	2.5	5	8	12.5	20	32	50	80	130	-	-	-	-
	1	1.6	3.2	4	6.3	10	16	25	40	63	-	-	-	-
Cage plug (LK)	2.5	4	6.3	12.5	20	32	50	80	100	130	250	320	580	-
	(LK)	3.2	5	10	16	25	40	63	80	100	200	-	-	-
	1.6	2.5	4	6.3	10	16	25	40	63	-	130	-	-	-

DN		340-2-B										340-BB			
		15	20	25	32	40	50	65	80	100	125	150	200	250	300
Standard	PN16	6.2	7.1	7.8	11.5	13.9	18.5	27.8	32.9	44.5	65.6	101	200	240	425
	PN25														
	PN40														
Cooling tube (K)	PN16	7.2	8.1	8.8	12.5	14.9	19.5	28.8	33.9	45.5	66.6	107	250	300	470
	PN25	7.7	8.6	9.3	13.5	16.4	21.5	31.8	37.9	50.5	73.6	117	270	345	540
	PN40	7.5	8.4	9.1	12.8	15.2	19.8	29.1	34.2	45.8	66.9	107.7	250	300	470
Cooling tube and bellows seal (K-SS)	PN16	7.5	8.4	9.1	12.8	15.2	19.8	29.1	34.2	45.8	66.9	107.7	250	300	470
	PN40	8	8.9	9.6	13.8	16.7	21.8	32.1	38.2	50.8	73.9	118	270	-	-
Balanced plug (EMF)	PN16	-	-	-	-	14.4	19	28.4	32.9	46.3	71	101	200	240	425
	PN25	-	-	-	-	15.9	21	31.4	36.9	51.3	78	111	252	310	518
	PN40	-	-	-	-	16.9	22	32.4	37.9	52.3	79	122	302	370	558
Cooling tube and balanced plug (K-EMF)	PN16	-	-	-	-	15.4	20	29.4	33.9	47.3	72	107	250	300	470
	PN25	-	-	-	-	15.4	20	29.4	33.9	47.3	72	107	250	300	470
	PN25 steel	-	-	-	-	15.4	20	29.4	33.9	47.3	72	107	250	320	450
	PN40	-	-	-	-	16.9	22	32.4	37.9	52.3	79	122	302	370	558

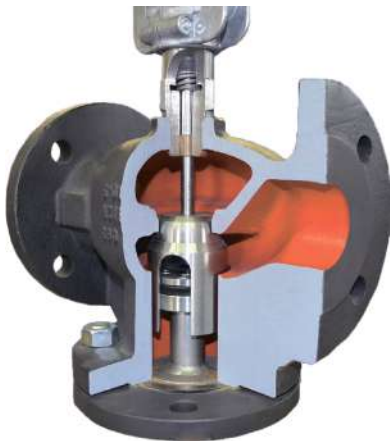

Sectional view of baelz 340-2-B-EMF plug



baelz 340-2-B-EMF balancing guide



baelz 340-2-B cage plug

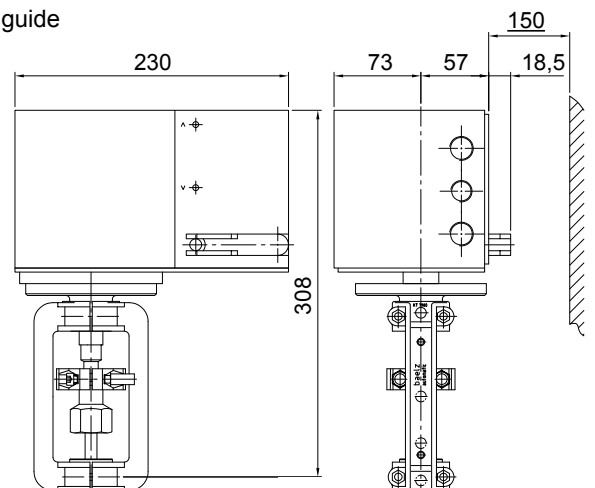

Dimensions of baelz 373-E65 actuator

Dimensions of the baelz 340 & 340-2 valves (mm)

DN	BL	h1			h2	
					340-2-B	340-2-BK / 340-2-BK-SS
15	130	101			110 (105)*	236 (231)*
20	150	103			110 (105)*	236 (231)*
25	160	113			110 (105)*	236 (231)*
32	180	130			104	283 (283)*
40	200	135			114	283 (281)*
50	230	147			124	293 (277)*
65	290	159			144	313 (269)*
80	310	166			154	323 (269)*
100	350	189			169	338 (262)*
125	400	243			189	358 (252)*
		PN16	PN25	PN40	340-BB	340-BBK / 340-BBK-SS
150	480	269	277	277	244	234
200	600	272	280	288	268	258
250	730	314	322	332	317	307
300	850	327	335	345	361	351

* Dimension h2 for previous version of baelz 340

Dimensions of the baelz 373 actuators (mm)

Designation	L	x	Ød	I	ØD
E07	320	145	129		
E45	560	150	175		
E65	see dimensional drawing on previous page				
P11				244	160
P21				268	242
P21-V6				304	242
P22				322	242
	340-BB/ 340-BB-EMF	340-BBK/ 340-BBK-SSF		340-BB/ 340-BB-EM	340-BBK/ 340-BBK-SS
E45	577	1057	150	175	
E66	614	1094	200	188 (258*)	
P31				509	989
P32				525	1005
P41				562	1042
P41-V6				687	1167

* Dimensions with manual operation

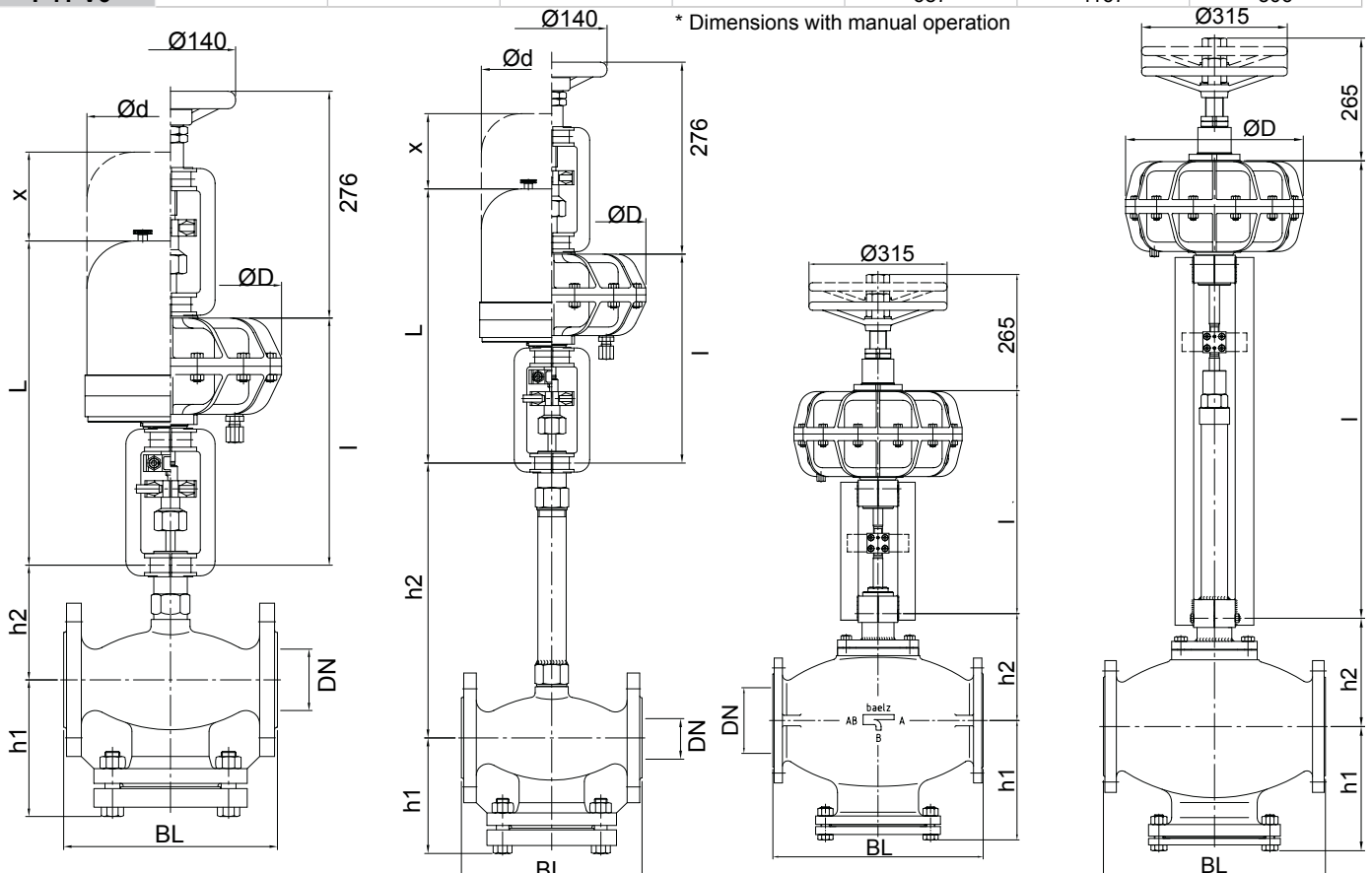

baelz 340-2-B DN15-125

baelz 340-2-B-EMF DN40-125

baelz 340-2-BK DN15-125

baelz 340-2-BK-SS DN15-125

baelz 340-BB DN150-300

baelz 340-BB-EMF DN150-300

baelz 340-BBK DN150-300

baelz 340-BBK-SS DN150-300

Maximum differential pressure ΔP_{max} (bar) at which the actuator closes the valve completely

The differential pressures specified here are limited by the nominal pressure of the housings, if this is lower.

Electric actuators. baelz 340-2-B/340-BB, 340-2-BK/340-BBK, 340-2-BK-SS/340-BBK-SS. Plug closes against the flow.

Actuator baelz 373-	Power (N)	DN (mm) / maximum differential pressure ΔP_{max} (bar)													
		15	20	25	32	40	50	65	80	100	125	150	200	250	300
E07- OSX-	700	14	14	10	5	2.5	1.2	0.3							
E07- 20-	2000	40	40	32	20	12	8	4.8	3	2	1.2				
E65- 11-	1100	25	25	21	11	6.3	3.5	1.7	0.9	0.3					
E65- 20-	2000	40	40	32	20	12	8	4.8	3	2	1.2				
E45- 40-	4000	40	40	40	40	25	16	10	6.9	4.4	2.8	1.7			
E66- 80-	8000											3.1	1.6	0.9	
E66- 150-	15000											7.1	3.8	2.3	1.5
E88- 100-	10000							28	18	11	7.4	5	2.7	1.7	1.1
E88- 100-	13000							37	24	15	9.8	6.7	3.7	2.3	1.5
E88- 100-	16000							40	30	19	12	8.4	4.6	2.9	2
E88- 300-	30000											15.3	9	5.8	3.9
E88- 300-	35000											18.9	10.5	6.7	4.6
E88- 300-	40000											21.7	12.1	7.7	5.3

Balanced 2-way valves for liquids and steam baelz 340-2-B-EMF, 340-BB-EMF. Plug closes against the flow.

Actuator baelz 373-	Power (N)	DN (mm) / maximum differential pressure ΔP_{max} (bar)													
		15	20	25	32	40	50	65	80	100	125	150	200	250	300
E07- OSX-	700					40	40	40	40						
E07- 20-	2000					40	40	40	40	40	40				
E65- 11-	1100					40	40	40	40						
E65- 20-	2000					40	40	40	40	40	40				
E45- 40-	4000					40	40	40	40	40	40	8.2			
E66- 80-	8000											24.8	15	9.7	6.3
E66- 150-	15000											40	40	29.1	22.1
E63- 440-	4448											10.3			
E88- 100-	10000											36.7	23.4	16.1	11.5
E88- 100-	13000											40	33.5	23.9	17.9
E88- 100-	16000											40	40	31.7	24.2
E88- 300-	30000											40	40	40	40
E88- 300-	35000											40	40	40	40
E88- 300-	40000											40	40	40	40



Maximum differential pressure ΔP_{max} (bar) at which the actuator closes the valve completely

The differential pressures specified here are limited by the nominal pressure of the housings, if this is lower.

2-way valves: baelz 340-2-B/340-BB, 340-2-BK/340-BBK, 340-2-BK/340-BBK-SS

Pneumatic actuators (OPG) closed without compressed air. Plug closes against the flow.

Actuator baelz 373-	Power (N)	required feed pressure (bar)	DN (mm) / maximum differential pressure ΔP_{max} (bar)													
			15	20	25	32	40	50	65	80	100	125	150	200	250	300
P11- 1	950	3.0	39.5	18.2	13.6	8.1	4.3	2.4	1.1	0.5						
P21- 3	1020	1.2	29	29	16	9.9	6.3	4.6	2.7	1.8	1	0.6				
P21- 6	2040	3.0	40	40	35	21	13.5	8.9	5.2	3.4	2.2	1.4				
P21- 12	3390	6.0	40	40	40	36	23	14	8	5	3.5	2.1				
P21- 18	4030	6.0	40	40	40	40	27	18	10	7	4.5	2.8				
P21- V6	7590	6.0	40	40	40	40	40	34	20	13	8	5				
P22- 3	1846	3.0	40	40	34.5	18.8	11	6.5	3.4	2	1.1	0.5				
P22- 6	3692	6.0	40	40	40	40	25.2	15.3	8.5	5.3	3.2	1.9				
P31- 3	2480	1.2											1.1			
P31- 6	4960	3.0											2.4			
P31- 18	10560	6.0											5.3			
P32- 6	4402	3.0												0.8		
P32- 18	8115	6.0												1.8		
P41- 3	3765	1.2											2.4	1	0.6	0.4
P41- 6	7530	3.0											5	2	1.3	0.9
P41- V6	31920	6.0											21	10.5	6.5	4.5

2-way valves: baelz 340-2-B/340-BB, 340-2-BK/340-BBK, 340-2-BK/340-BBK-SS

Pneumatic actuators (OPO) open without compressed air. Plug closes against the flow.

Actuator baelz 373-	Power (N)	required feed pressure (bar)	DN (mm) / maximum differential pressure ΔP_{max} (bar)														
			15	20	25	32	40	50	65	80	100	125	150	200	250	300	
P11- 1	2111	6.0	40	40	40	29.2	17	10.5	5.8	3.7							
P21- 3	1020	1.2	7	7	4.5	2.8	1.8	1.1	0.6	0.4	-	-					
		3.0	40	40	40	40	31	19	12	8	5	3					
P21- 6	2040	6.0	40	40	40	40	40	40	30	20	12	8					
		3.0	40	40	35	21	14	8	5.3	3.5	2.2	1.4					
P31- 3	2480	6.0	40	40	40	40	40	39	24	16	10	6					
		1.2												0.6			
P31- 6	4960	3.0												6			
		6.0												14.8			
P41- 3	3765	3.0												3			
		6.0												12			
P41- 6	7530	1.2												1.2	0.7	0.4	0.3
		3.0												12	6.8	4.3	3
P41- 6	7530	6.0												30	17	11	7.5
		3.0													5	3	2
		6.0												15	10	6	

Balanced 2-way valves for liquids and steam: baelz 340-2-B-EMF, 340-BB-EMF

Pneumatic actuators (OPG) closed without compressed air. Plug closes against the flow.

Actuator baelz 373-	Power (N)	required feed pressure (bar)	DN (mm) / maximum differential pressure ΔP_{max} (bar)														
			15	20	25	32	40	50	65	80	100	125	150	200	250	300	
P11- 1	950	3.0					40	40	40	40							
P21- 3	1020	1.2					40	40	40	40							
P21- 6	2040	3.0					40	40	40	40	40	40					
P22- 3	1846	3.0					40	40	40	40	40	40					
P22- 6	3692	6.0					40	40	40	40	40	40					
P31- 3	2480	3.0												1			
P31- 6	4960	3.0												12.8			
P31- 18	10560	6.0												39.4			
P32- 6	4402	3.0													4.6	1.6	
P32- 18	8115	6.0													17.1	11.2	7.5
P41- 3	3765	1.2												7.1	2.5		
P41- 6	7530	3.0												24.9	15.1	9.7	6.3
P41- V6	31920	6.0												40	40	40	40

Sectional drawings of the baelz 340-2 plug

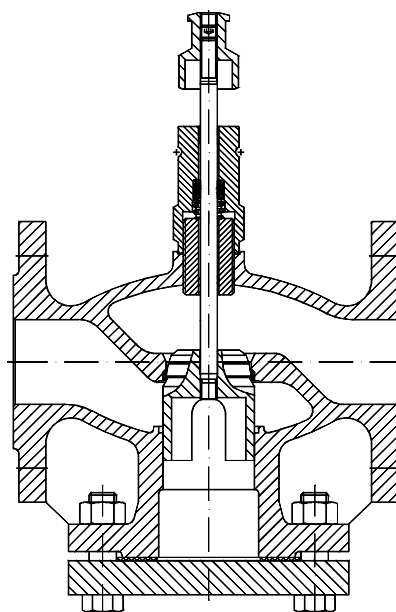

baelz 340-2-B parabolic plug with slot guides

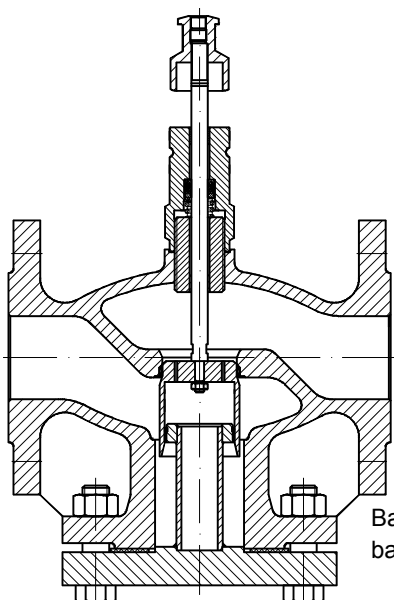

Balanced plug
baelz 340-2-B-EMF

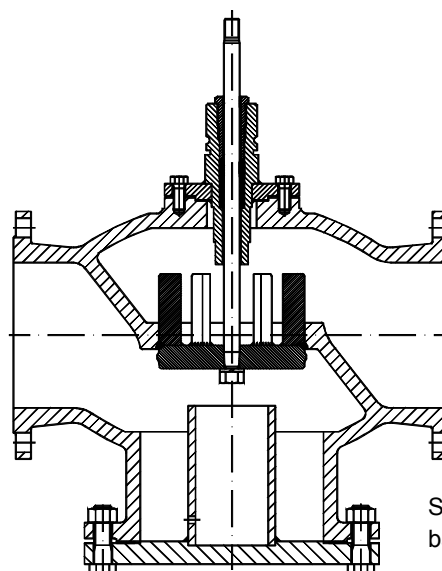

Slit plug
baelz 340-BB

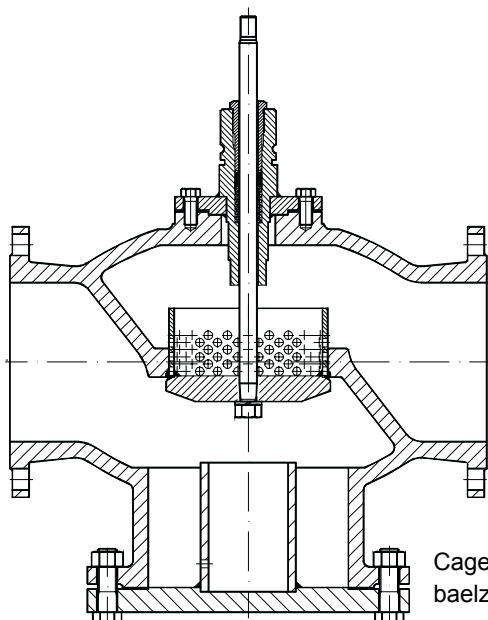

Cage plug
baelz 340-BB-LK

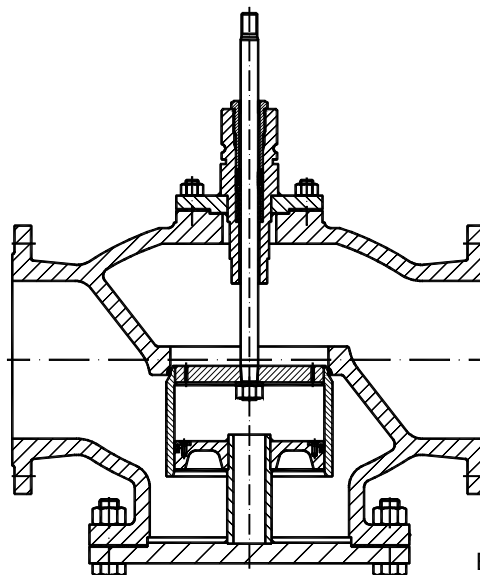

Balanced plug
baelz 340-BB-EMF



baelz 344

DESCRIPTION

The baelz 344 is an industrial 2-way control valve. The stainless steel housing allows utilization under demanding operating conditions.

TECHNICAL SPECIFICATIONS

Connection type: Flange EN 1092-2; EN 1092-1 Shapes D / E / F on request.

Plug type: parabolic plug / conical

Control characteristic: equal percentage, linear, OPEN / CLOSED

Working fluids: liquids, water, thermal oil, steam, gases

Leakage class (EN 1349)

metal-to-metal seal: 0.004% Kvs (better than class IV)
with PTFE plug: 0.001% Kvs (better than class VI)

Stroke (mm)

Stroke (mm)	Spindle Ø (mm)
DN 65	22
DN 80	22
DN 100, DN 125	22
DN 150	44

Spindle Ø (mm)

	Options	Designation
Plug	Parabolic plug (standard)	baelz 344...
Spindle seal	V-rings in PFTE standard	baelz 344...
	Cooling tube	MP344-K
	Cooling tube + double-walled stainless steel bellows seal	MP344-SS...
Additional options	V-shaped seal heating (for fluids at temperatures of - 10 to - 40°C) Pmax. 20 W; 12-24 V / 110-230 V AC/DC	baelz 85950...
	Version for drinking water	MP344-Twg

T max. (°C) / P max. (bar)

Housing material	Stainless steel 1.4408 (internal parts in contact with working fluid 1.4571)	
Nominal pressure	PN 16	PN 25/40
baelz 344	240/12.8 ... 100/16	240/32.1 ... 100/40
baelz 344-EMF	350/11.4 ... 100/16	350/28.5 ... 100/40
baelz 344-K	350/11.4 ... 100/16	350/25 ... 100/40
baelz 344-K-SS	350/11.4 ... 100/16	350/25 ... 100/40

Sectional drawings of the baelz 344 plug

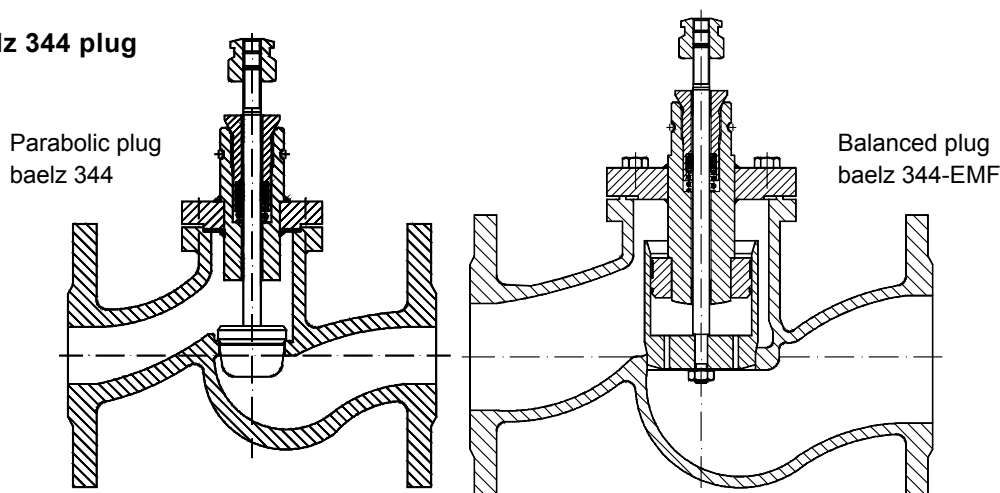

DN	Kvs value (m³/h)				
	65	80	100	125	150
Standard	-	100	130	200	360
Balanced (EMF)	63				
Cage plug (LK)	on request				

DN	Approximate weights of the baelz 344 valves (kg)				
	65	80	100	125	150
PN 16	28.4	28.7	39	57	90
PN 25/40	28.4	29.7	41	60	93

Dimensions of the baelz 344 valves (mm)			
DN	BL	h1	h2
80	310	154	189
100	350	169	208
125	400	189	227
150	480	194	261

Dimensions of the baelz 373 actuators (mm)					
Designation	L	x	Ød	l	ØD
E07	320	145	129		
E45	560	150	175		
E65	see dimensional drawing below				
P11				244	160
P21				268	242
P21-V6				304	242
P22				322	242

Electric actuators: baelz 373-E
 Pneumatic actuators: baelz 373-P

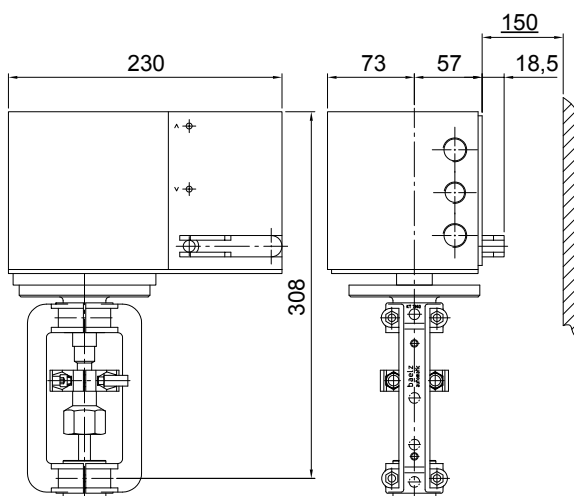

Dimensions of the baelz 373-E65 actuator

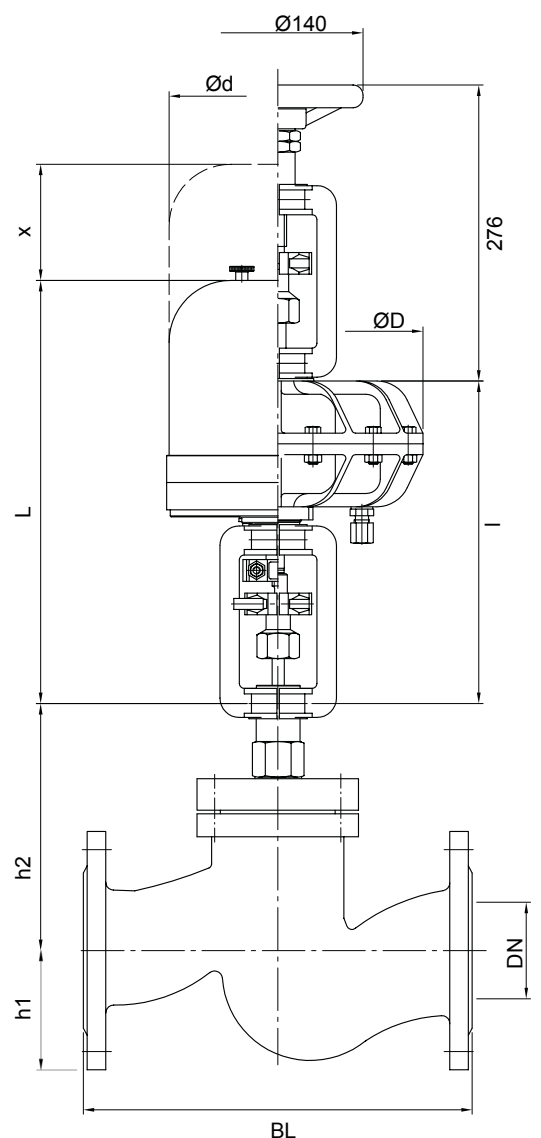

baelz 344 dimensions

Maximum differential pressure ΔP_{max} (bar) at which the actuator closes the valve completely

The differential pressures specified here are limited by the nominal pressure of the housings, if this is lower.

Electric actuators. Plug closes against the flow.

Actuator baelz 373-	Power (N)	DN (mm) / maximum differential pressure ΔP_{max} (bar)													
		15	20	25	32	40	50	65	80	100	125	150	200	250	300
E07- OSX-	700	14	14	10	5	2.5	1.2	0.3							
E07- 20-	2000	40	40	32	20	12	8	4.8	3	2	1.2				
E65- 11-	1100	25	25	21	11	6.3	3.5	1.7	0.9	0.3					
E65- 20-	2000	40	40	32	20	12	8	4.8	3	2	1.2				
E45- 40-	4000	40	40	40	40	25	16	10	6.9	4.4	2.8	1.7			
E66- 80-	8000											3.1	1.6	0.9	
E66- 150-	15000											7.1	3.8	2.3	1.5
E88- 100-	10000							28	18	11	7.4	5	2.7	1.7	1.1
E88- 100-	13000							37	24	15	9.8	6.7	3.7	2.3	1.5
E88- 100-	16000							40	30	19	12	8.4	4.6	2.9	2
E88- 300-	30000											15.3	9	5.8	3.9
E88- 300-	35000											18.9	10.5	6.7	4.6
E88- 300-	40000											21.7	12.1	7.7	5.3

Pneumatic actuators (OPG) closed without compressed air. Plug closes against the flow.

Actuator baelz 373-	Power (N)	req. feed pressure (bar)	DN (mm) / maximum differential pressure ΔP_{max} (bar)													
			15	20	25	32	40	50	65	80	100	125	150	200	250	300
P11- 1	950	3.0	39.5	18.2	13.6	8.1	4.3	2.4	1.1	0.5						
P21- 3	1020	1.2	29	29	16	9.9	6.3	4.6	2.7	1.8	1	0.6				
P21- 6	2040	3.0	40	40	35	21	13.5	8.9	5.2	3.4	2.2	1.4				
P21- 12	3390	6.0	40	40	40	36	23	14	8	5	3.5	2.1				
P21- 18	4030	6.0	40	40	40	40	27	18	10	7	4.5	2.8				
P21- V6	7590	6.0	40	40	40	40	40	34	20	13	8	5				
P22- 3	1846	3.0	40	40	34.5	18.8	11	6.5	3.4	2	1.1	0.5				
P22- 6	3692	6.0	40	40	40	40	25.2	15.3	8.5	5.3	3.2	1.9				
P31- 3	2480	1.2											1.1			
P31- 6	4960	3.0											2.4			
P31- 18	10560	6.0											5.3			
P32- 6	4402	3.0												0.8		
P32- 18	8115	6.0												1.8		
P41- 3	3765	1.2											2.4	1	0.6	0.4
P41- 6	7530	3.0											5	2	1.3	0.9
P41- V6	31920	6.0											21	10.5	6.5	4.5

Pneumatic actuators (OPO) open without compressed air. Plug closes against the flow.

Actuator baelz 373-	Power (N)	req. feed pressure (bar)	DN (mm) / maximum differential pressure ΔP_{max} (bar)													
			15	20	25	32	40	50	65	80	100	125	150	200	250	300
P11- 1	2111	6.0	40	40	40	29.2	17	10.5	5.8	3.7						
		1.2	7	7	4.5	2.8	1.8	1.1	0.6	0.4						
P21- 3	1020	3.0	40	40	40	40	31	19	12	8	5	3				
		6.0	40	40	40	40	40	40	30	20	12	8				
P21- 6	2040	3.0	40	40	35	21	14	8	5.3	3.5	2.2	1.4				
		6.0	40	40	40	40	40	39	24	16	10	6				
P31- 3	2480	1.2											0.6			
		3.0											6			
		6.0											14.8			
P31- 6	4960	3.0											3			
		6.0											12			
P41- 3	3765	1.2											1.2	0.7	0.4	0.3
		3.0											12	6.8	4.3	3
		6.0											30	17	11	7.5
P41- 6	7530	3.0												5	3	2
		6.0												15	10	6



baelz 356-1 & 356-2

DESCRIPTION

The baelz 356 is a 2-way control valve with a heat resistant steel or stainless steel housing for industrial applications. Several plug shapes allow utilization for various control tasks under demanding operating conditions.

TECHNICAL SPECIFICATIONS

Connection type: Flange EN 1092-2; EN 1092-1 Shapes D / E / F on request.

Plug type: parabolic plug / conical

Control characteristic: equal percentage, linear, OPEN / CLOSED

Working fluids: liquids, gases, water, steam, thermal oil

Leakage class (EN 1349)
metal-to-metal seal: 0.004% Kvs (better than class IV)
with PTFE plug: 0.001% Kvs (better than class VI)

Stroke		Spindle diameter
DN 15 - DN 25	16 mm	10mm
DN 32 - DN 65	22mm	

Options		Description
Plug	Parabolic plug, stainless steel (standard)	baelz 356-1... / baelz 356-2...
	cage plug	MP356-LK...
	PTFE plug	MP356-TK...
	several Kvs values available	baelz 356-1...Kvs XX / baelz 356-2...Kvs XX
Spindle seal	V-rings in PTFE (Standard)	baelz 356-1... / baelz 356-2...
	Cooling tube	baelz 356-1(-VA)-K... / baelz 356-2-VA-K...
	Double-walled stainless steel bellows seal	MP356-SS
Additional options	V-ring seal heating (for fluids at temperatures of - 10 to - 40 °C) Pmax. 20 W; 12-24 V / 110-230 V AC/DC	baelz 85950...
	Silicone free version	MP356-Silf
	Version for drinking water	MP356-Twg

Model	T max. (°C) / P max. (bar)			
	Stainless steel 1.4571		Heat resistant steel 1.0460	
Housing material	PN 25/40		PN 25/40	PN 16
Nominal pressure	PN 25/40		PN 25/40	PN 16
Nominal diameter	DN 15-25	DN 32-65	DN 32-50	DN 65
baelz 356-1	-	-	240/35...50/40	240/12.3...50/16
baelz 356-1-K	-	-	350/25.7...50/40	350/10.2...50/16
baelz 356-1-VA	240/40...100/40	240/35.7...100/40	-	-
baelz 356-1-VA-K ¹⁾	350/40...100/40	350/32.1...100/40	-	-
baelz 356-2-VA-K ²⁾	-	-	-	-
baelz 356-1-K + MP356-SS	-	-	-	350/10.2...50/16
baelz 356-1-VA-K ¹⁾ + MP356-SS	350/25...100/25		-	-
baelz 356-2-VA-K ²⁾ + MP356-SS	350/25...100/25		-	-

1) DN 32 - DN 65; 2) DN 15 - DN 25

Note: As we are constantly improving our products, there is more than one series of this article. When ordering spares or parts for an existing system, please state the old serial numbers and, if in doubt, contact Baelz. We'll be pleased to help.

Housing	Kvs value (m ³ /h)										
	1.4571						1.0460				
DN	15	20	25	32	40	50	65	32	40	50	65
Standard	3.8	7.3	9.3	15	25	40	63	15	25	42	63
	2	4	6.5	10	14	23	38	10	14	23	38
Cage plug LK	1	2	4	7	10	15	23	7	10	15	23
	2.5	4	6.3	12.5	18.5	25	40	12.5	18.5	25	40
	2	2.5	4	6.3	12.5	18.5	25	6.3	12.5	18.5	25
	1.4	2.0	2.5	4	6.3	12.5	18.5	4	6.3	12.5	18.5
	0.6										

Approximate weights of the baelz 356 valves (kg)							
DN	15	20	25	32	40	50	65
baelz 356	5.5	6.1	6.6	10	11.8	15.6	19
baelz 356-K	5.7	6.4	7.2	10.5	12.3	16.1	19.5

Dimensions of the baelz 356 valves (mm)				
DN	BL	h1	h2	
			356	356-K/K-SS
15	130	40	106	331
20	150	45	106	331
25	160	55	106	331
32	180	62	111	358
40	200	73	132	372
50	230	90	142	382
65	290	101	182	425

Dimensions of the baelz 373 actuators (mm)					
Designation	L	x	Ød	l	ØD
E07	320	145	129		
E45	560	150	175		
E65	see dimensional drawing below				
P11				244	160
P21				268	242
P21-V6				304	242
P22				322	242

Electric actuators: baelz 373-E
 Pneumatic actuators: baelz 373-P

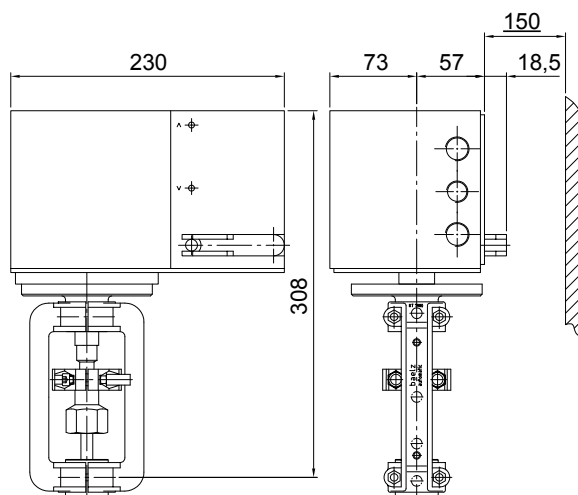

Dimensions of the baelz 373-E65 actuator

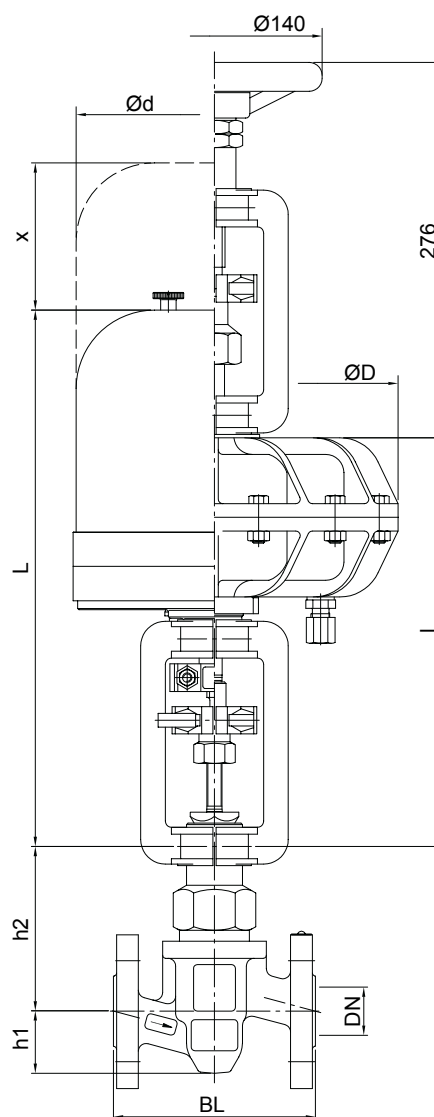

baelz 356 DN15-65 dimensions

baelz 356-1 & 356-2 2-way control valve differential pressure tables



Maximum differential pressure ΔP_{max} (bar) at which the actuator closes the valve completely
 The differential pressures specified here are limited by the nominal pressure of the housings, if this is lower.

Electric actuators. Plug closes against the flow.

Actuator baelz 373-	Power (N)	DN (mm) / maximum differential pressure ΔP_{max} (bar)														
		15	20	25	32	40	50	65	80	100	125	150	200	250	300	
E07- OSX-	700	14	14	10	5	2.5	1.2	0.3								
E07- 20-	2000	40	40	32	20	12	8	4.8	3	2	1.2					
E65- 11-	1100	25	25	21	11	6.3	3.5	1.7	0.9	0.3						
E65- 20-	2000	40	40	32	20	12	8	4.8	3	2	1.2					
E45- 40-	4000	40	40	40	40	25	16	10	6.9	4.4	2.8	1.7				
E66- 80-	8000												3.1	1.6	0.9	
E66- 150-	15000												7.1	3.8	2.3	1.5
E88- 100-	10000							28	18	11	7.4	5	2.7	1.7	1.1	
E88- 100-	13000							37	24	15	9.8	6.7	3.7	2.3	1.5	
E88- 100-	16000							40	30	19	12	8.4	4.6	2.9	2	
E88- 300-	30000												15.3	9	5.8	3.9
E88- 300-	35000												18.9	10.5	6.7	4.6
E88- 300-	40000												21.7	12.1	7.7	5.3

Pneumatic actuators (OPG) closed without compressed air. Plug closes against the flow.

Actuator baelz 373-	Power (N)	required feed pressure (bar)	DN (mm) / maximum differential pressure ΔP_{max} (bar)														
			15	20	25	32	40	50	65	80	100	125	150	200	250	300	
P11- 1	950	3.0	39.5	18.2	13.6	8.1	4.3	2.4	1.1	0.5							
P21- 1	950	1.2	40	18.3	13.7	8.2	4.3	2.4	1.1								
P21- 3	1020	1.2	29	29	16	9.9	6.3	4.6	2.7	1.8	1	0.6					
P21- 6	2040	3.0	40	40	35	21	13.5	8.9	5.2	3.4	2.2	1.4					
P21- 12	3390	6.0	40	40	40	36	23	14	8	5	3.5	2.1					
P21- 18	4030	6.0	40	40	40	40	27	18	10	7	4.5	2.8					
P21- V6	7590	6.0	40	40	40	40	40	34	20	13	8	5					
P22- 3	1846	3.0	40	40	34.5	18.8	11	6.5	3.4	2	1.1	0.5					
P22- 6	3692	6.0	40	40	40	40	25.2	15.3	8.5	5.3	3.2	1.9					
P31- 3	2480	1.2												1.1			
P31- 6	4960	3.0												2.4			
P31- 18	10560	6.0												5.3			
P32- 6	4402	3.0													0.8		
P32- 18	8115	6.0													1.8		
P41- 3	3765	1.2												2.4	1	0.6	0.4
P41- 6	7530	3.0												5	2	1.3	0.9
P41- V6	31920	6.0												21	10.5	6.5	4.5

Pneumatic actuators (OPO) open without compressed air. Plug closes against the flow.

Actuator baelz 373-	Power (N)	required feed pressure (bar)	DN (mm) / maximum differential pressure ΔP_{max} (bar)														
			15	20	25	32	40	50	65	80	100	125	150	200	250	300	
P11- 1	2111	6.0	40	40	40	29.2	17	10.5	5.8	3.7							
		1.2	7	7	4.5	2.8	1.8	1.1	0.6	0.4							
P21- 3	1020	3.0	40	40	40	40	31	19	12	8	5	3					
		6.0	40	40	40	40	40	40	30	20	12	8					
P21- 6	2040	3.0	40	40	35	21	14	8	5.3	3.5	2.2	1.4					
		6.0	40	40	40	40	40	39	24	16	10	6					
P31- 3	2480	1.2												0.6			
		3.0												6			
		6.0												14.8			
P31- 6	4960	3.0												3			
		6.0												12			
P41- 3	3765	1.2												1.2	0.7	0.4	0.3
		3.0												12	6.8	4.3	3
		6.0												30	17	11	7.5
P41- 6	7530	3.0													5	3	2
		6.0													15	10	6



baelz 356
cage plug

Sectional drawings of the baelz 356 plug

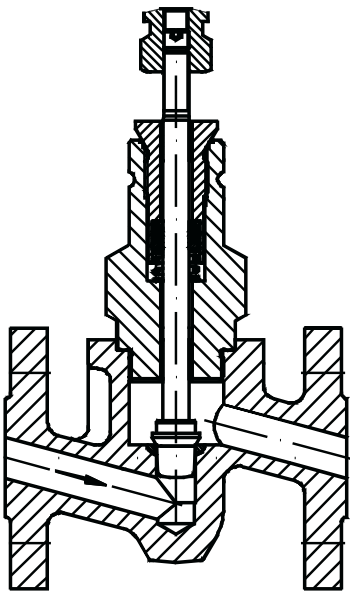

Parabolic plug
baelz 356-1-VA

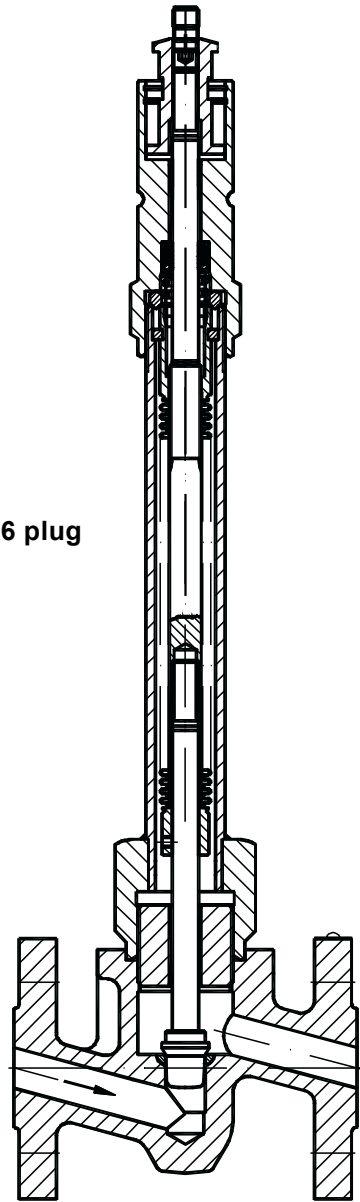

Parabolic plug
baelz 356-1-VA-K-SS

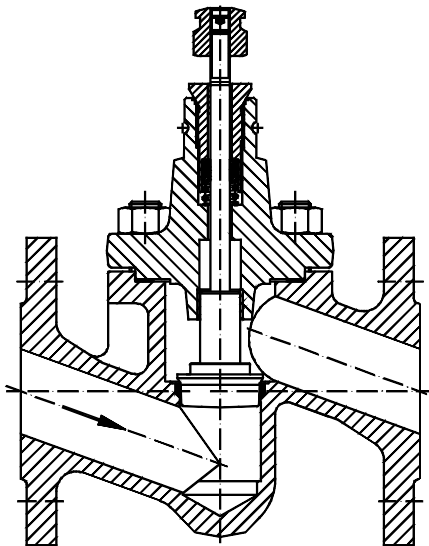

Parabolic plug
baelz 356-1

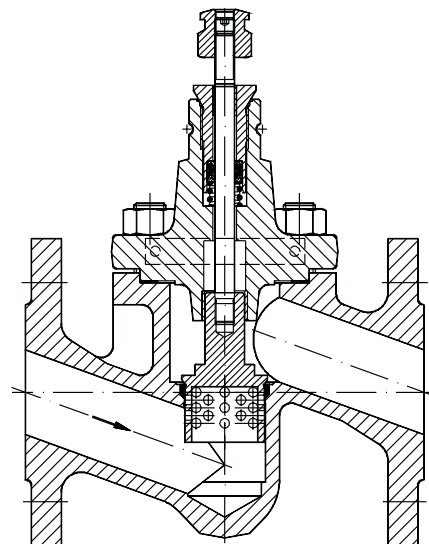

Cage plug
baelz 356-1-LK



baelz 358-K / 359-K

DESCRIPTION

The baelz 358-K and 359-K control valves are 2-way valves with cooling tube for systems with high temperatures and pressures.

TECHNICAL SPECIFICATIONS

Connection type: Flange EN 1092-2; EN 1092-1 Shapes D / E / F on request.

Plug type: parabolic plug / conical

Control characteristic: equal percentage, linear, OPEN / CLOSED

Stroke - 16 mm / 22 mm

Working fluids: liquids, gases, water, steam

Leakage class (EN 1349)

metal-to-metal seal: 0.004% Kvs (better than class IV)

Housing material baelz 358-K, baelz 359-K

Nominal diameter	DN 15...DN 25	from DN 32
Housing material 358-K	Steel 13CrMo4-5 - 1.7335	Cast steel G17CrMo5-5 - 1.7357
Housing material 359-K	Steel P250GH - 1.0460	GP240GH+N - 1.0619+N

T max. (°C) / P max. (bar)

Nominal pressure	PN 63	PN 100	PN 160
baelz 358-K	350 / 60	350 / 95.2	350 / 152.3
	300 / 63	300 / 100	300 / 160
baelz 359-K	350 / 40.5	350 / 64.2	350 / 102.8
	240 / 48.9	240 / 77.5	240 / 124.1
	50 / 63	50 / 100	50 / 160

Dimensions, weight and Kvs values for baelz 358-K and baelz 359-K, DN 20 - DN 125						
DN	BL	h2	Weight, approx.			Metric flow factor (Kvs) (m³/h)
			PN 63	PN 100	PN 160	
(mm)			(kg)			
15	210	370			8.5	3.8
20	230	370			10	7.3
25	230	380			11.5	9.3
32	260	384			15.5	15
40	260	389			20.5	25
50	300	409	29 / 31*	29 / 31*	29 / 31*	42
65	340	220	38 / 40*	43 / 45*	43 / 45*	63
80	380	230	52*	58*	58*	105
100	430	255	62*	75*	75*	130
125	500	305	100*	104*	110*	200

* with Ø 22 mm spindle (358-K-22 and 359-K-22). Otherwise with Ø 10 mm spindle.

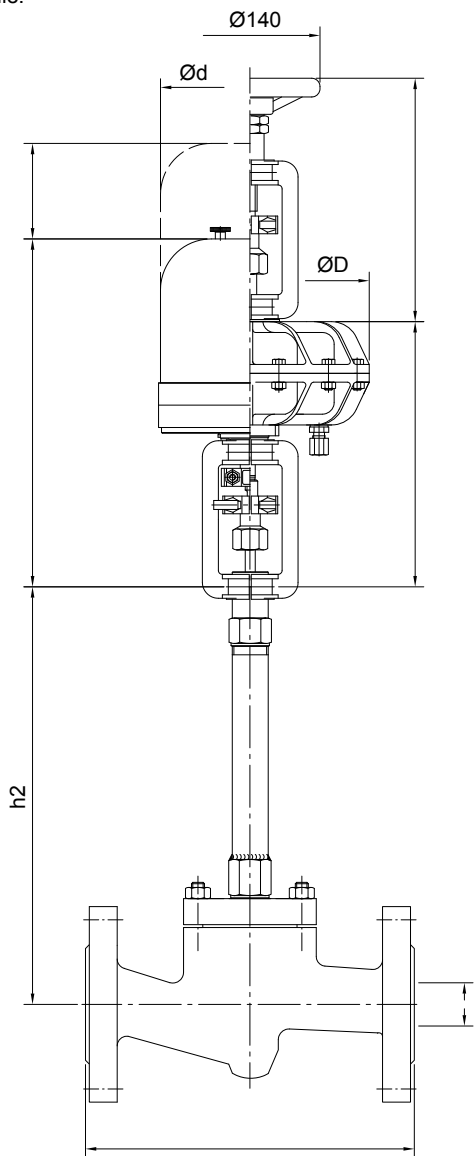

Dimensions baelz 358-K / 359-K, DN 20 - DN 50

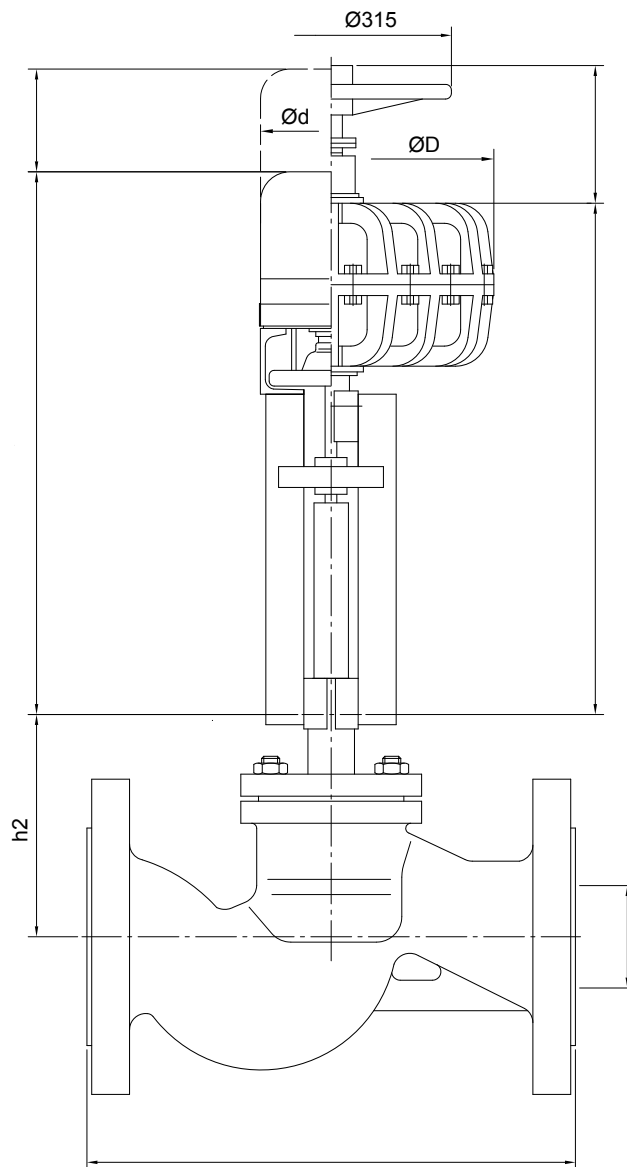

Dimensions baelz 358-K / 359-K, DN 65 - DN 125

Dimensions of the Baelz 373 actuators (mm)					
Designation	L	x	Ød	l	ØD
E07	317	145	129		
E11	499	180	183		
P21				268	242
P21-V6				304	242
P22				322	242
P31				989	384
P32				1005	384
P41				1042	506
P41-V6				1167	506

Electric actuators: baelz 373-E

Pneumatic actuators: baelz 373-P

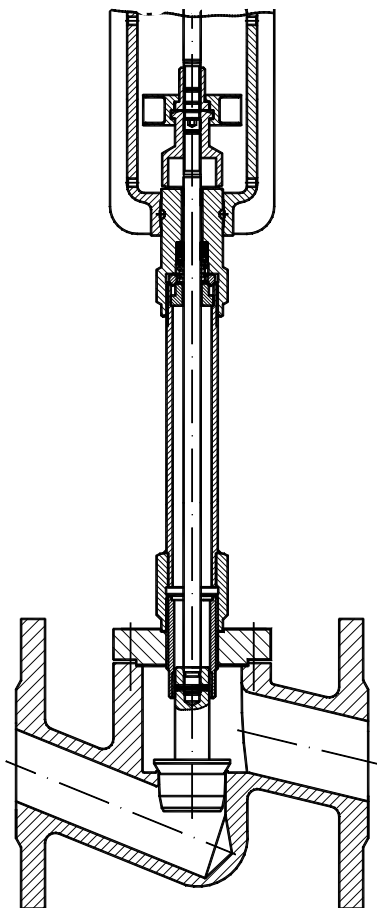

Parabolic plug
baelz 358-K / 359-K, DN 20 - DN 50

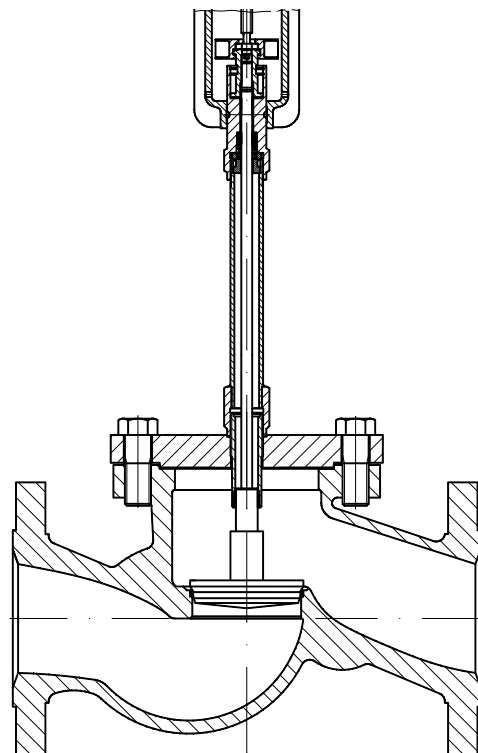

Parabolic plug
baelz 358-K / 359-K, DN 65 - DN 125

Sectional drawings of the baelz 358-K, baelz 359-K plugs

Electric actuators. 2-way valves for high pressures. Plug closes against the flow.

Actuator baelz 373-	Power (N)	DN (mm) / maximum differential pressure ΔP_{max} (bar)														
		15	20	25	32	40	50	65	80	100	125	150	200	250	300	
E07- 20-	2000	92	41	32	20	11.4										
E65- 20-	2000	92	41	32	20	11.4										
E45- 40-	4000	160	89	68	44	25.7	16.1									
E66- 80-	8000	160	160	132	85	51	32	18.7								
E66- 150-	15000	160	160	160	160	104	66	40								
E88- 100-	10000	160	160	160	115	68	43	25.4								
E88- 100-	13000	160	160	160	151	90	57	33.6								
E88- 100-	16000	160	160	160	160	111	71	41.7								
E88- 300-	30000									52.3	33.3	21.1				

Pneumatic actuators (OPG) closed without compressed air. 2-way valves for high pressures. Plug closes against the flow.

Actuator baelz 373-	Power (N)	req. feed pressure (bar)	DN (mm) / maximum differential pressure ΔP_{max} (bar)													
			15	20	25	32	40	50	65	80	100	125	150	200	250	300
P21- 6	2040	3.0	95	43	32.6	20.4	11.7									
P21- 12	3390	6.0	160	75	57	36.5	21.3	13.2								
P21- 18	4030	6.0	160	90	69	44	25.9	16.2								
P21- V6	7590	6.0	160	160	134	87	52	32.5	18.9							
P22- 6	3692	6.0	160	82	63	40	23.5	14.7								
P31- 6	4960	3.0	160	112	86	55	32.6	20.5	11.8							
P31- 18	10560	6.0	160	160	160	122	73	46	27							



baelz 360

DESCRIPTION

The baelz 360 is an extremely robust, balanced 2-way control valve with steel housing and cage plug. It is designed to withstand large variations in quantity, pressure, temperature and humidity of steam and condensate.

TECHNICAL SPECIFICATIONS

Connection type: Flange EN 1092-2; EN 1092-1 Shapes D / E / F on request.

Plug type: balanced piston plug with perforated cage, hardened and optimally guided

Control characteristic: equal percentage / linear

Working fluids: liquids, gases, water, steam

Leakage class (EN 1349)
metal-to-metal seal: 0.004% Kvs (better than class IV)
with PTFE plug: 0.001 % Kvs (better than class VI)*

*on request

Stroke* (mm)		Spindle Ø (mm)
DN 32 - DN 40	22	10
DN 50 - DN 125	22	16
DN 150	44	22

*Stroke 12 / 40 mm on request

Options		Designation
Plug	Balanced piston plug with perforated cage (standard)	baelz 360-EM-C...
	Balanced piston plug with double perforated cage for higher pressure drops	MP360-CC...
Spindle seal	V-rings in PFTE (standard)	
	Cooling tube	MP360-K
Additional options	V-shaped seal heating (for fluids at temperatures of - 10 to - 40°C) Pmax. 20 W; 12-24 V / 110-230 V AC/DC	baelz 85950...

T max. (°C) / P max. (bar)	
Housing material	Cast steel GP240GH - 1.0619
Nominal pressure	PN 40
baelz 360-EM-C baelz 360-EM-CC	250 / 30.4 ... 50 / 40
baelz 360-K-EM-C baelz 360-K-EM-CC	315 / 27 ... 50 / 40

DN	Kvs value* (m³/h)									Control characteristic
	25**	32	40	50	65	80	100	125	150	
baelz EM-C	3,5	7	11	18	45	56	62	80	110	Equal percentage
baelz EM-CC	8,0	11,5	20	30	55	90	108	138	200	Linear

Notes: *The baelz 360 is configured to customer requirements, the Kvs values above should therefore be regarded as guideline values.

**Nominal diameter DN 25 with a stroke of 12 mm available on request.

Approximate weights of the baelz 360 valves (kg)							
DN	40	50	65	80	100	125	150
baelz 360 EM-C	15.3	19.6	31	36.7	51	71	
baelz 360 EM-CC			31	36.7	51	71	
							120

Dimensions of the baelz 360 valves			
DN	BL / PN40	h1	h2 / PN40
360-EM-C/CC			
40	200	100	177
50	230	80	225
65	290	100	242
80	310	110	249
100	350	125	269
125	400	145	321
150	480	194	330
360-K-EM-C/CC			
40	200	100	467
50	230	80	520
65	290	100	532
80	310	110	539
100	350	125	559
125	400	145	611
150	480	194	620

Dimensions of the baelz 373 actuators (mm)					
Designation	L	x	Ød	l	ØD
E 07	320	145	129		
E 45	560	150	175		
E65	see dimensional drawing below				
P 21				268	242
P 21-V6				304	242
P 22				322	242

Electric actuators: baelz 373-E
 Pneumatic actuators: baelz 373-P

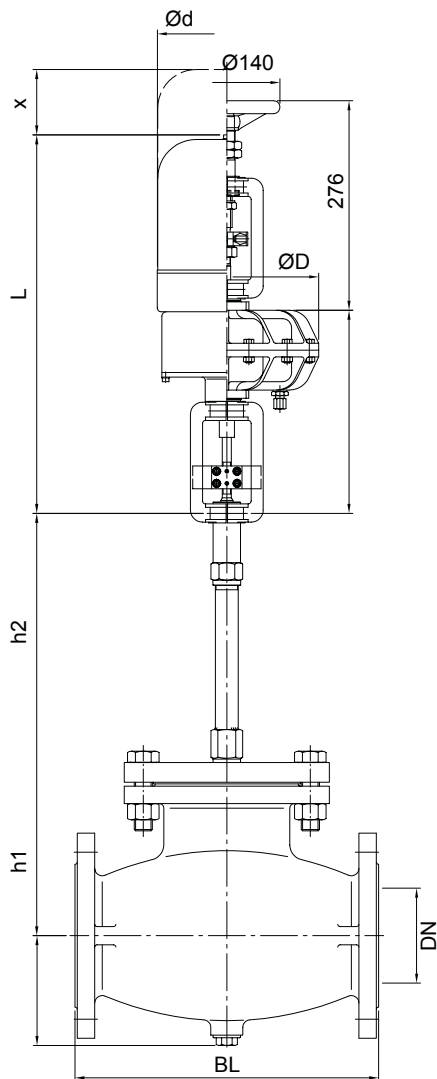

Dimensions 360-EM-C-K 40-125

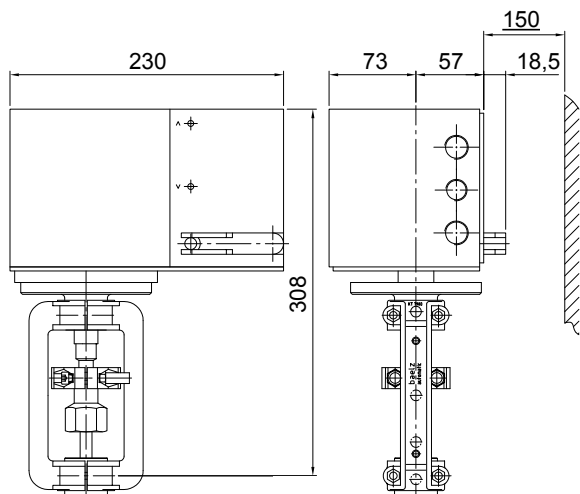

Dimensions of the baelz 373-E65 actuator

Maximum differential pressure ΔP_{max} (bar) at which the actuator closes the valve completely

The differential pressures specified here are limited by the nominal pressure of the housings, if this is lower.

Electric actuators. Balanced 2-way valves for liquids and steam Plug closes in direction of flow.

Actuator baelz 373-	Power (N)	DN (mm) / maximum differential pressure ΔP_{max} (bar)														
		15	20	25	32	40	50	65	80	100	125	150	200	250	300	
E07- OSX-	700					-	-	-	-							
E07- 20-	2000					146	55	67	61	52	42					
E65- 11-	1100					53	18	17	11	2.6						
E65- 20-	2000					146	55	67	61	52	42					
E45- 40-	4000					160	129	160	160	151	142	68	58			
E66- 80-	8000											160	150			
E66- 150-	15000											160	160			

Pneumatic actuators (OPG) closed without compressed air. Balanced 2-way valves for liquids and steam Plug closes in direction of flow.

Actuator baelz 373-	Power (N)	req. feed pressure (bar)	DN (mm) / maximum differential pressure ΔP_{max} (bar)													
			15	20	25	32	40	50	65	80	100	125	150	200	250	300
P21- 3	1020	1.2					55	19.3	18.6	12.9	3.6					
P21- 6	2040	3.0					150	57	69	63	54	44				
P22- 3	1846	3.0					132	50	59	54	44	35				
P22- 6	3692	6.0					160	118	151	146	136	127				
P31- 3	2480	3.0												28.4		
P31- 6	4960	3.0												93		
P32- 6	4402	3.0													68	
P41- 3	3765	1.2												62	52	
P41- 6	7530	3.0												160	151	

Sectional drawings of the baelz 360 plug

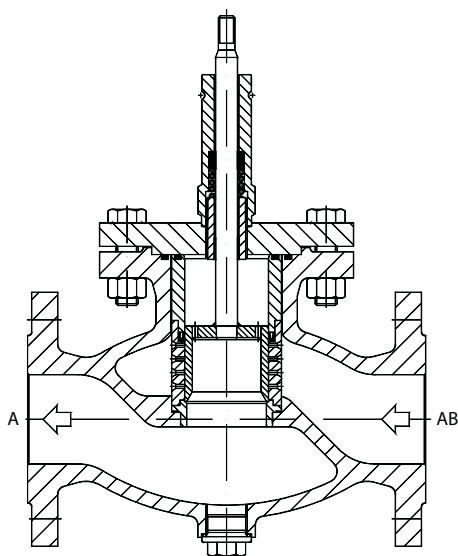

Piston plug and cage
baelz 360-EM-C

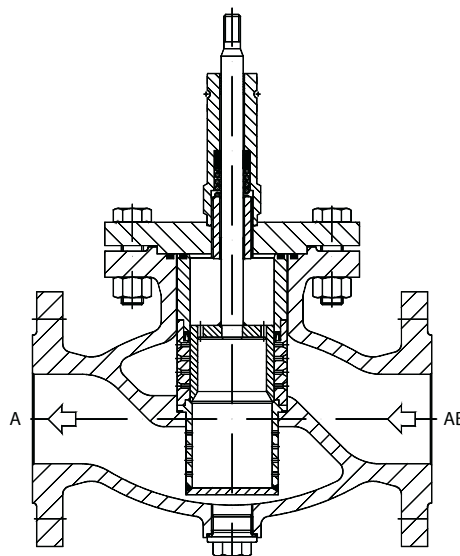

baelz 360-EM-CC with additional
perforated cage



baelz 365 & 365-2

DESCRIPTION

The baelz 365 / 365-2 ANSI 300 valve is a flanged and pressure rated 2-way control valve in accordance with US ANSI / ASME standards.

TECHNICAL SPECIFICATIONS

Connection type: ASME / ANSI B16.5 flange

Plug type: parabolic plug

Control characteristic: equal percentage

Working fluids: liquids, gases, water, steam, thermal oil

Leakage class (EN 1349)

metal-to-metal seal: 0.004% Kvs (better than class IV)

For NPS 1 1/2" - 4", designation = baelz 365-2
 For NPS 6", designation = baelz 365.
 Other sizes available on request.

Technical Specifications		Designation
Housing material	1.0619 (1.0432) / SA216WCB (SA105)	baelz 365-2... / baelz 365...
T max. / P max.	450 °F/620 psi; 100 °F/740 psi 232 °C/42,7 bar; 38 °C/51.1 bar	baelz 365-2...
	650 °F/550 psi; 100 °F/740 psi 343 °C/37,9 bar; 38 °C/51.1 bar	baelz 365-2-K...
	650 °F/362 psi; 100 °F/362 psi 343 °C/25 bar; 38 °C/25 bar	baelz 365-K-SS...
Plug	Parabolic plug (standard)	baelz 365-2... / baelz 365...
Cooling tube / Spindle seal	V-rings in PTFE standard	baelz 365-2... / baelz 365...
	Cooling tube	baelz 365-2-K...
	Cooling tube + double-wall stainless steel bellows seal and safety gland	baelz 365-2-K-SS... / baelz 365-K-SS...
Additional options	V-shaped seal heating (for fluids at temperatures of - 10 to - 40°C) Pmax. 20 W; 12-24 V / 110-230 V AC/DC	baelz 85950...

baelz 365 & 365-2 ANSI 300 valve stroke, seat diameter and Kvs values						
NPS	1 1/2"	2"	2 1/2"	3"	4"	6"
Stroke (")	0.87	0.87	0.87	0.87	0.87	1.73
Seat Ø (")	1.57	1.97	2.55	3.15	3.93	5.9
Cv (US GPM)	29.2	42.0	73.5	122.6	165.8	420
Nominal diameter, DN (mm)	40	50	65	80	100	150
Stroke (mm)	22	22	22	22	22	44
Seat Ø (mm)	40	50	65	80	100	150
Kvs value (m³/h)	25	36	63	105	142	360

Note: As we are constantly improving our products, there is more than one series of this article. When ordering spares or parts for an existing system, please state the old serial numbers and, if in doubt, contact Baelz. We'll be pleased to help.

Dimensions of the Baelz actuators										
Actuator	L		x		Ød		l		ØD	
	inches	mm	inches	mm	inches	mm	inches	mm	inches	mm
E07	12.60	320	5.71	145	5.0	129				
E 45	13.66	347	5.9	150	6.81	173				
E 65	12.17	309	-	-	9.06	230 wide*				
E 66	24.17/43.19 ⁺	614/1094 ⁺	7.87	200	7.40	188				
P 21							10.6	268	9.5	242
P 21-V6							11.9	304	9.5	242
P22							12.68	322	9.5	242

⁺ with yoke S41/with yoke S41C

* dimensions, see datasheet of actuator E65

baelz 365-K-SS & 365-2-K-SS approximate dimensions and weights									
NPS / DN		BL		h1		h2		weight	
in.	mm	in.	mm	in.	mm	in.	mm	lbs	kg
1 1/2"	40	9.25	235	5.94	151	11.14	283	26.1	11.8
2"	50	10.51	267	6.61	168	11.54	293	40.1	18.2
2 1/2"	65	11.5	292	7.24	184	12.32	313	54.7	24.8
3"	80	12.52	318	7.83	199	12.72	323	69.7	31.6
4"	100	14.49	368	8.98	228	13.31	338	115	51.9
6"	150	17.62	473	11.42	290	on request		262	118

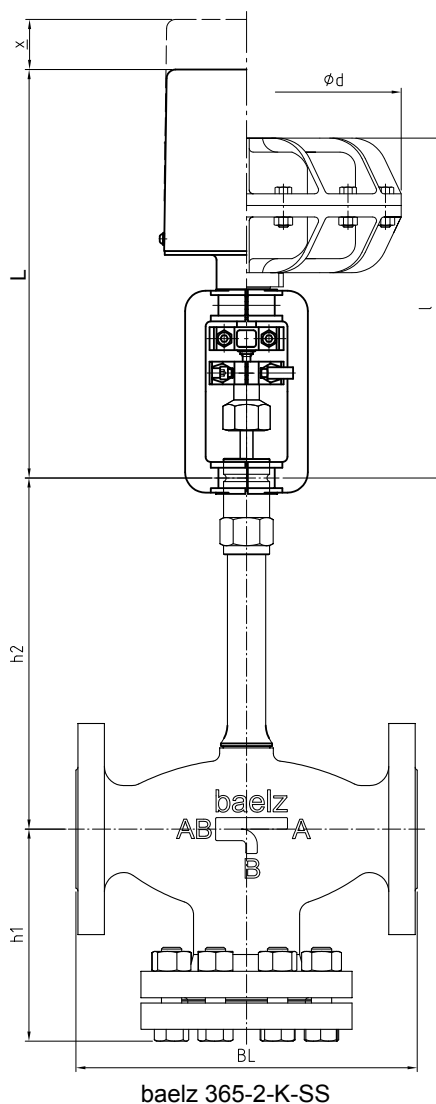

Maximum differential pressure ΔP_{max} (bar) at which the actuator closes the valve completely

The differential pressures specified here are limited by the nominal pressure of the housings, if this is lower.

Electric actuators. Plug closes against the flow.

Actuator baelz 373-	Power (N)	DN (mm) / maximum differential pressure ΔP_{max} (bar)							
		40	50	65	80	100	125	150	
E07- OSX	700	2.5	1.2	0.3					
E07- 20-	2000	12	8	4.8	3	2	1.2		
E65- 11-	1100	6.3	3.5	1.7	1.5	1	0.6		
E65- 20-	2000	12	8	4.8	3	2	1.2		
E45- 40-	4000	25	16	10	6.9	4.4	2.8		1.7
E66- 80-	8000								3.1
E66- 150-	15000								7.1
E88- 100-	10000			28	18	11	7.4		5
E88- 100-	13000			37	24	15	9.8		6.7
E88- 100-	16000			40	30	19	12		8.4
E88- 300-	30000								15.3
E88- 300-	35000								18.9
E88- 300-	40000								21.7

Pneumatic actuators (OPG) closed without compressed air. Plug closes against the flow.

Actuator baelz 373-	Power (N)	req. feed press. (bar)	DN (mm) / maximum differential pressure ΔP_{max} (bar)							
			40	50	65	80	100	125	150	
P11- 1	950	3.0	4.3	2.4	1.1	0.5				
P21- 3	1020	1.2	6.3	4.6	2.7	1.8	1	0.6		
P21- 6	2040	3.0	13.5	8.9	5.2	3.4	2.2	1.4		
P21- 12	3390	6.0	23	14	8	5	3.5	2.1		
P21- 18	4030	6.0	27	18	10	7	4.5	2.8		
P21- V6	7590	6.0	40	34	20	13	8	5		
P22- 3	1846	3.0	11	6.5	3.4	2	1.1	0.5		
P22- 6	3692	6.0	25.2	15.3	8.5	5.3	3.2	1.9		
P31- 3	2480	1.2								1.1
P31- 6	4960	3.0								2.4
P31- 18	10560	6.0								5.3
P41- 3	3765	1.2								2.4
P41- 6	7530	3.0								5
P41- V6	31920	6.0								21



Please note that actuators utilized as safety devices as defined by the Pressure Equipment Directive (PED 2014/68) are subject to certification.
Certification costs on request.

Leakage class (EN 1349)

metal-to-metal seal: 0.004% Kvs (better than class IV)
with PTFE plug: 0.001% Kvs (better than class VI)

baelz 192

DESCRIPTION

The baelz 192 is a direct-acting pressure reducing valve with pilot control for steam. The pilot valve allows accurate maintenance of the vapor pressure level in the utility appliance.

The valve opening requires a minimum pressure difference of 1 bar. It is equipped with the 206r pilot pressure controller .

TECHNICAL SPECIFICATIONS

Connection type: Flange EN 1092-2; EN 1092-1 Shapes D / E / F on request.
Working fluid: steam

SPECIAL FEATURES

The 265st built-in solenoid valve guarantees completely vapor-tight closing of the main valve in the event of operation interruptions. Delivery without solenoid at a reduced price is possible. In this case, vapor-tight closing of the valve is not guaranteed. Relevant for systems in permanent function, as well as systems with a isolating valve upstream from the reducing valve.

Stroke		Designation
DN15-25	6 mm	192/4
DN32-40	12 mm	
DN50	14 mm	
DN65	18 mm	
DN80	20 mm	192/5
DN100	25 mm	
DN125	30 mm	

Options		Designation
Plug	Parabolic plug (standard)	baelz 192
	Cage plug	baelz 192-LK
Flange	EN 1092-1 Shapes D / E / F on request	baelz 192-VR

T max. (°C) / P max. (bar)		
Housing material	Spheroid ductile iron GJS-400-18-LT - 5.3103	Cast steel GP240GH - 1.0619
Nominal pressure	PN16	PN40
baelz 192	240 / 10 ... 120 / 13	240 / 32 ... 120 / 32
Min. ambient temperature (°C)	20	

Kvs value (m³/h)											
DN	15	20	25	32	40	50	65	80	100	125	150
Standard	5	6	8	15	24	35	70	105	135	200	320
Cage plug LK	2.5	3.2	4	10	16	25	40	63	100	160	200
	2	2.5	2.5	6.3	10	16	32	50	80	130	160
	1.3	1.6		4	8		25	40	40	100	
							16				

Weight, approx. (kg)											
DN	15	20	25	32	40	50	65	80	100	125	150
baelz 192	30	31	32	38	44	53	59	145	155	185	220
baelz 192 + 206r / 206r2 pressure measuring and control element + 265st solenoid element	35	36	37	43	49	58	64	150	160	190	225

baelz 192 dimensions (mm)								
DN	BL	H	h	B1	B2		B3	ØM
		PN 16/40			PN16	PN40		
15	130	560	110	80	185		180	270
20	150	560	110	85	185		185	270
25	160	570	110	90	185		190	270
32	180	565	145	125	185		225	270
40	200	565	145	125	185		225	270
50	230	580	160	125	185		225	270
65	290	595	180	140	185	215	240	270
80	310	930	210	175	290		270	420
100	350	950	235	190	290		285	420
125	400	930	255	210	290		305	420
150	480	945	265	225	290		320	420

Technical specifications for the 206r and 206r2 pilot valve - pressure controller

Dimensions		Application area	
x (mm)	L (mm)	T max. (°C)	P max. (bar)
100	353	110	18
200	453	200	18
300	553	240	13

Controller type	Pressure range (bar)	Housing and bellows seal material	Connection
206r	0.05 ... 0.45	Stainless steel 1 4571	G 1/2
	0.08 ... 0.65		
	0.14 ... 1		
206r2	0.3 ... 2.5	Stainless steel 1.4571	G 1/2
	0.5 ... 3.4		
	0.9 ... 6.4		
	2 ... 8.8		
	3.4 ... 18		

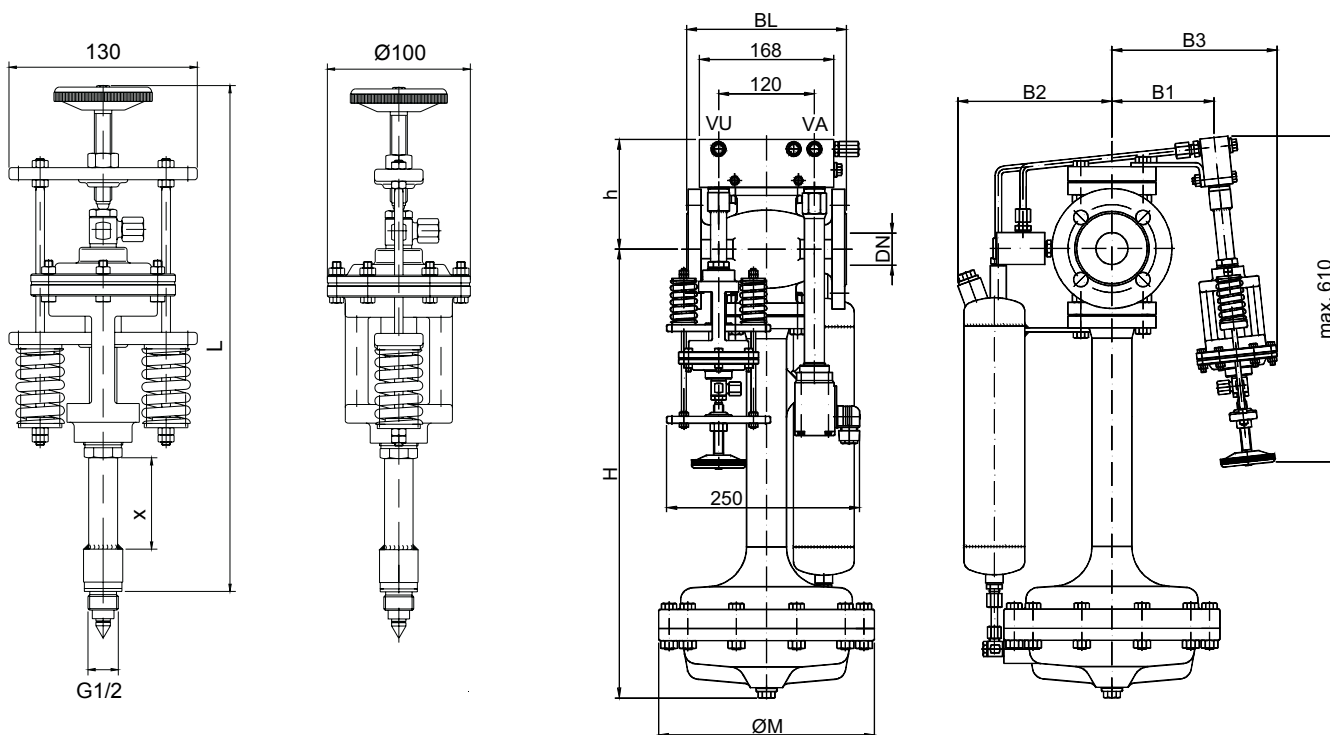

baelz 206r and 206r2 pressure maintenance valve

baelz 192 universal steam valve DN 15 - 65 PN 16 - 40 with baelz 206r and baelz 265st pressure control element

Sectional drawing of baelz 192 valve

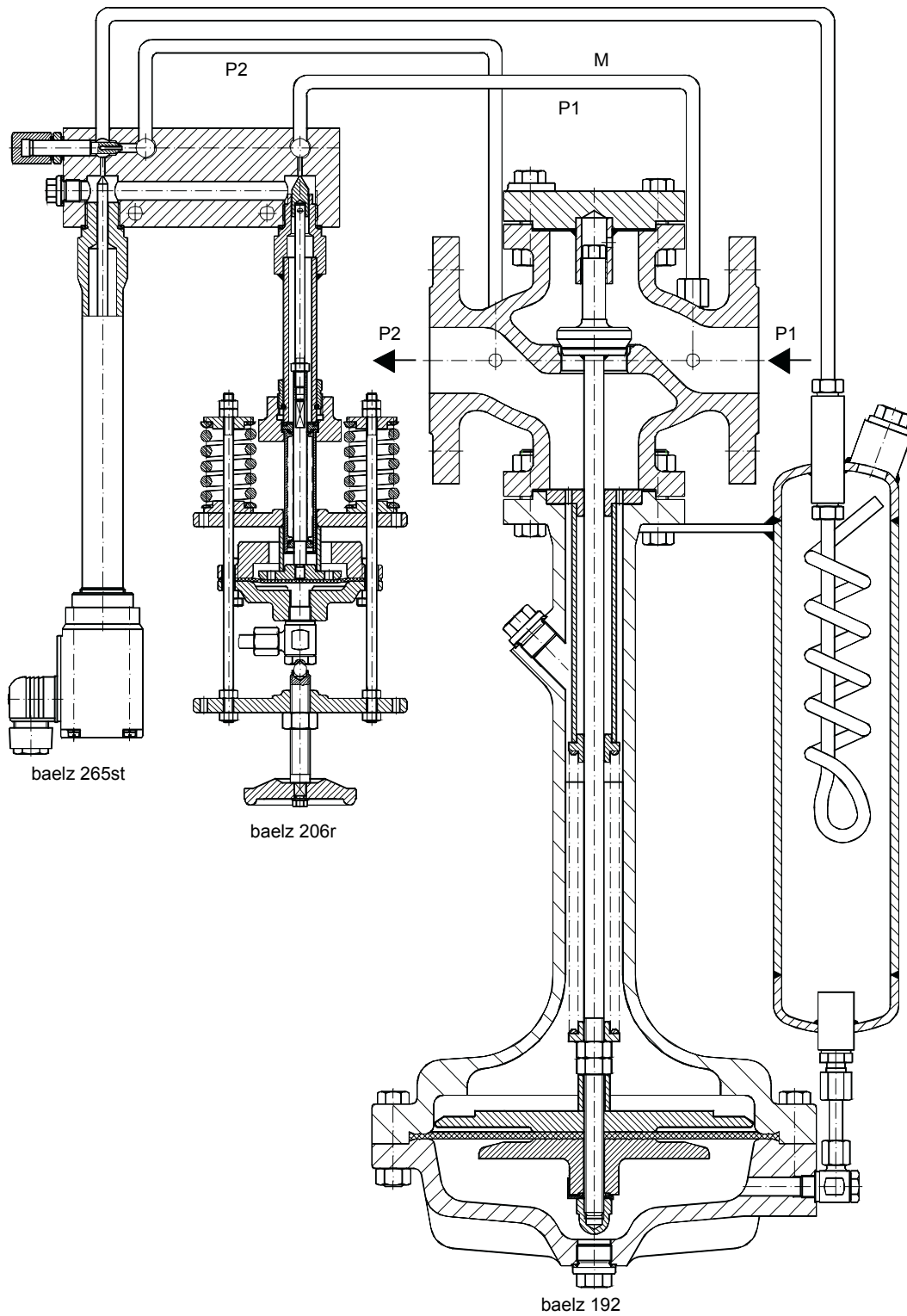

baelz 192 direct acting reducing valve
with baelz 206r pilot controller and baelz 265st isolating valve

page 48

baelz 335



- 1/2"– 1 1/2"
- PN 16 / 25
- External thread/for welding
- Housing CC491K - CuSn5Zn5Pb5-C
- max. 150°C
- Silicone seal
- Water, hot water, steam



page 51

baelz 342-2-B



- DN 15-125
- PN16 / 25
- Flanged connection
- Housing 5.3103 / 1.4313
- max. 240°C
- Cage plug
- Liquids, water, hot water, steam, gases



page 51

baelz 342-2-BK-SS



- DN 15-125
- PN 16 / 25 / 40
- Flanged connection
- Housing 5.3103 / 1.0619
- max. 350°C
- Cage plug
- Cooling tube
- Bellows seal
- Liquids, water, thermal oil, steam, gases



page 55

**baelz 347 & 347-2-B
baelz 347 & 347-2B
baelz 347 & 347-2-B-EMF
baelz 347 & 347-2B-EMF**



- DN 15-350
- PN 16 / 25 / 40
- Flanged connection
- Housing 5.3103 / 1.0619 / 1.4313
- max. 240°C
- Cage plug
- Balanced plug (EMF)
- Reduced Kvs
- Liquids, water, hot water, steam, gases



page 55

**baelz 347 & 347-2-BK-SS
baelz 347 & 347-2BK-SS**



- DN 15-350
- PN 16 / 25 / 40
- Flanged connection
- Housing 5.3103 / 1.0619 / 1.4313
- max. 350°C
- Cage plug
- Reduced Kvs
- Cooling tube
- Bellows seal
- Liquids, water, thermal oil, steam, gases



page 62

baelz 353 / 354



- DN 15-25 / DN 32-150
- PN 16 / 25 / 40
- Flanged connection
- Housing 1.4571 / 1.4408 / 1.4313
- max. 350°C
- Cage plug
- Reduced Kvs
- Cooling tube
- Liquids, water, thermal oil, steam, gases



page 65

baelz 367 & 367-2-2-A3
baelz 367 & 367-2-A3
baelz 367-2-K-SS-A3
baelz 367-K-SS-A3



- 1/2" - 10" / DN 15-250
- ANSI 300
- Flanged connection
- Housing SA216WCB - 1.0619
- max. 230°C / 400°C
- Cooling tube optional
- Bellows seal optional
- Liquids, water, thermal oil, steam, gases





baelz 335

DESCRIPTION

The baelz 335 is a 3-way control valve with red brass housing for heating, ventilation and air conditioning systems.

TECHNICAL SPECIFICATIONS

Connection type: external thread / for welding
 Plug type: standard control plug with slot (lantern shape)
 Control characteristic: linear
 Stroke: 12 mm

Additional option: silicone seal
 Working fluids: water, hot water, steam

Leakage class (EN 1349)

Straight way (A-AB): 0.004 % Kvs (better than class IV)

Angle way (B-AB): 2 % Kvs (class I)

Options		Designation
Plug	Stainless steel 1. 4571 standard	baelz 335-1
Spindle seal	V-rings in PTFE standard	baelz 335-1
Connection	Brass union nut + steel nozzle for welding (standard)	baelz 335-1
	Brass union nut + weld-on stainless steel sockets	MP335-ASE...
	Brass union nut + threaded brass sockets	MP335-GT...

T max. (°C) / P max. (bar)	
Housing material	Red brass CC491K - CuSn5Zn5Pb5
Nominal pressure	PN 16 / 25
baelz 335-1	
baelz 335-GT	Water: 150 / 25
baelz 335-ASE	Steam 150 / 10

Actuators	Identification
Electric linear actuator	baelz 373-E
Pneumatic diaphragm actuator	baelz 373-P

Kvs value (m ³ /h)					
DN	1/2"	3/4"	1"	1 1/4"	1 1/2"
Kvs	3.5	5	9	16	16

baelz 335 dimensions and weight without actuator (mm)					
DN		BL	h1	h2	Weight, approx.
		(mm)			(kg)
1/2"	15	92	33	72	1.5
3/4"	20	95	40	72	1.7
1"	25	105	45	72	1.8
1 1/4"	32	105	53	72	2
1 1/2"	40	114	57	72	2.5

Dimensions of the Baelz actuators (mm)					
Designation	L	x	Ød	l	ØD
E07	320	145	129		
E45	560	150	175		
P11				244	160
P21				268	242

Sectional drawing of the baelz 335 plug

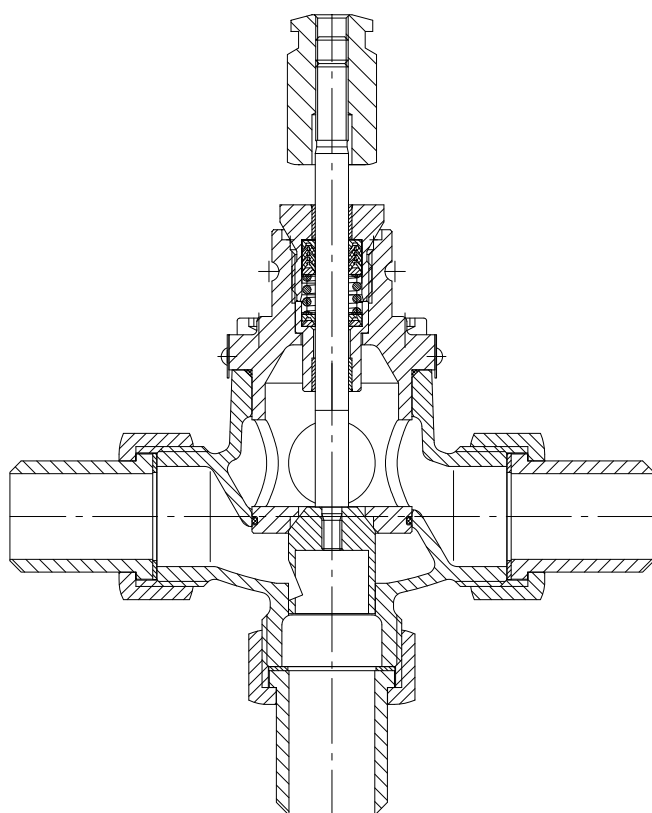

Standard control plug with slot
(lantern shape)
baelz 335

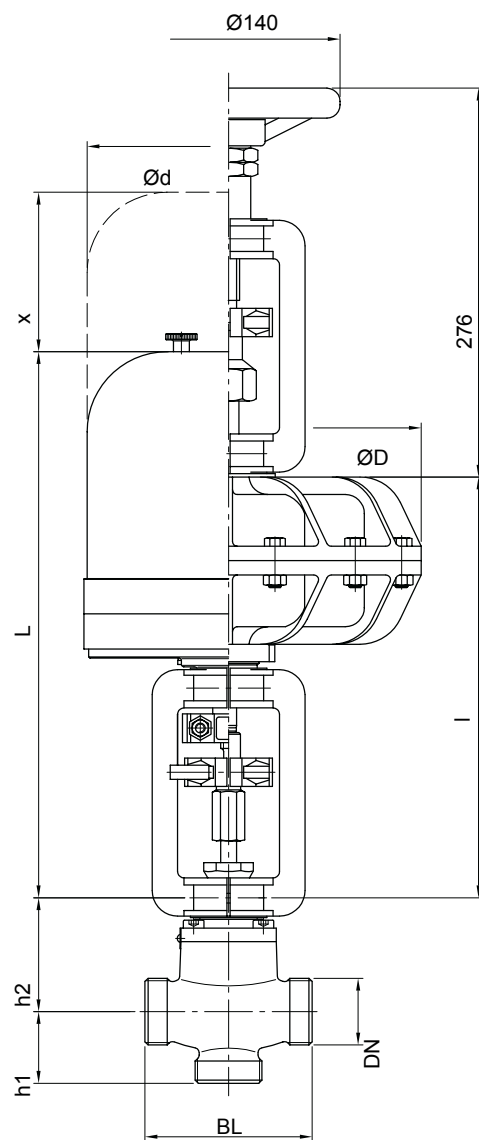

baelz 335 dimensions

Maximum differential pressure ΔP_{max} (bar) at which the actuator closes the valve completely
 The differential pressures specified here are limited by the nominal pressure of the housings, if this is lower.

Electric actuators. 3-way valves as mixing valves. Plug closes against the flow.

Actuator baelz 373-	Power (N)	DN (mm) / maximum differential pressure ΔP_{max} (bar)													
		15	20	25	32	40	50	65	80	100	125	150	200	250	300
E07- OSX-	700	14	14	10	5	2.5	1.2	0.3							
E07- 20-	2000	40	40	32	20	12	8	4.8	3	2	1.2				
E65- 11-	1100	25	25	21	11	6.3	3.5	1.7	0.9	0.3					
E65- 20-	2000	40	40	32	20	12	8	4.8	3	2	1.2				
E45- 40-	4000	40	40	40	40	25	16	10	6.9	4.4	2.8	1.7			
E66- 80-	8000											3.1	1.6	0.9	
E66- 150-	15000											7.1	3.8	2.3	1.5
E88- 100-	10000							28	18	11	7.4	5	2.7	1.7	1.1
E88- 100-	13000							37	24	15	9.8	6.7	3.7	2.3	1.5
E88- 100-	16000							40	30	19	12	8.4	4.6	2.9	2
E88- 300-	30000											15.3	9	5.8	3.9
E88- 300-	35000											18.9	10.5	6.7	4.6
E88- 300-	40000											21.7	12.1	7.7	5.3

Pneumatic actuators. 3-way valves as mixing valves. Plug closes against the flow.

Actuator baelz 373-	Power (N)	req. feed pressure (bar)	DN (mm) / maximum differential pressure ΔP_{max} (bar)													
			15	20	25	32	40	50	65	80	100	125	150	200	250	300
P11- 1	950	6.0	18.6	18.6	13.9	5.6	3.4	1.9	0.9	0.4						
P21- 3	1020	1.2	7	7	4.5	2.8	1.7	1.1	0.7	0.4	0.3	0.2				
P21- 6	2040	3.0	40	40	33	20	13	8	5	3.3	2.1	1.3				
P21- 12	3390	6.0	40	40	40	35	22	14	8.5	5.6	3.6	2.3				
P21- 18	4030	6.0	40	40	40	40	27	17	10	7	4.3	2.7				
P21- V6	7590	6.0	40	40	29	18	11.5	7	4.3	2.8	1.8	1.2				
P31- 3	2480	1.2											0.6			
P31- 6	4960	3.0											2.3			
P31- 18	10560	6.0											5			
P41- 3	3765	1.2											2.4	1	0.6	0.4
P41- 6	7530	3.0											4.8	2	1.3	0.9
P41- V6	31920	6.0											8.2	3.5	2.3	1.6

Pneumatic actuators. 3-way valves as diverting valves. Plug closes in direction of flow.

Actuator baelz 373-	Power (N)	req. feed pressure (bar)	DN (mm) / maximum differential pressure ΔP_{max} (bar)													
			15	20	25	32	40	50	65	80	100	125	150	200	250	300
all		1.2 - 6.0	Deploy all diverting valves only up to 0.6 bar differential pressure. If a diverting valve with > 0.6 bar is required, valve with > 0.6 bar is required, a damping device must be provided on the actuator.													



baelz 342-2

DESCRIPTION

The baelz 342-2 is a universal 3-way valve for industrial applications.

TECHNICAL SPECIFICATIONS

Connection type: Flange EN 1092-2; EN 1092-1 Shapes D / E / F on request.
 Plug type: parabolic plug / conical
 Control characteristic: linear
 Working fluids: liquids, water, thermal oil, steam, gases

Leakage class (EN 1349)
Straight way (A-AB): 0.004 % Kvs (better than class IV)
Angle way (B-AB): 2 % Kvs (class I)

Stroke (mm)	Spindle diameter (mm)
DN 15-25	12
DN 32-125	22

Options		Designation
Plug	Parabolic plug (standard)	baelz 342-2-B...
	Cage plug	MP342-LK...
Spindle seal	V-rings in PTFE standard	baelz 342-2-B...
	Cooling tube	baelz 342-2-BK...
	Cooling tube + bellows seal	baelz 342-2-BK-SS...
Flanges	Flange facing: groove all sides	MP342-ALL-N...
Additional options	V-shaped seal heating (for fluids at temperatures of - 10 to - 40°C) Pmax. 20 W; 12-24 V / 110-230 V AC/DC	baelz 85950...
	Construction without silicone	MP342-Silf...

Housing material	T max. (°C) / P max. (bar)			
	Spheroid ductile iron GJS-400-18-LT - 5.3103		Cast steel GP240GH - 1.0619	
Nominal pressure	PN 6	PN 16	PN 16/25	PN 40
baelz 342-2-B	240/5.2 ... 50/6	-	240/22 ... 50/25	-
baelz 342-2-BK	-	-	350/17.5 ... 50/25	350/25.7 ... 50/40
baelz 342-2-BK-SS	-	350/11.2 ... 50/16	-	350/25 ... 50/25

DN	Kvs value (m³/h)									
	15	20	25	32	40	50	65	80	100	125
Standard	5.9 3 2	7.8	9.6	16	25	36	63	105	130	200
Cage plug (LK)	2.5	4	6.3	12.5	20	32	50	80	100	
	2	3.2	5	10	16	25	40	63	80	130
	1.6	2.5	4	6.3	10	16	25	40	63	100

Note: As we are constantly improving our products, there is more than one series of this article. When ordering spares or parts for an existing system, please state the old serial numbers and, if in doubt, contact Baelz. We'll be pleased to help.

baelz 342-2 plug variants				
Valve function	Actuator type	Pressure difference at the plug (bar)	Nominal diameter	Plug type
Flow separation	Electric actuator	≤0.6	DN15 - 125	without restrictions
		>0.6	DN15 - 32	without restrictions
		>0.6	DN40 - 125	balanced (EMF) see baelz 347-2*
	Pneumatic actuator	≤0.6	DN15 - 125	without restrictions
		>0.6	DN15 - 32	on request
Flow mix	without restrictions		DN40 - 125	balanced (EFM) see baelz 347-2*

* Baelz will be pleased to inform you about possible applications with other plug variants

Approximate weights of baelz 342-2 valves without actuator (kg)											
DN		15	20	25	32	40	50	65	80	100	125
Standard (B)	PN16	5.5	6.1	6.6	9.6	11.8	15.6	24	28.7	39	57
	PN25	-	-	-	-	-	-	-	-	-	-
With cooling tube (BK)	PN16	6.5	7.1	7.6	10.6	12.8	16.6	-	29.7	-	-
	PN25	-	-	-	-	-	-	25	40	58	-
	PN40	7	7.6	8.1	11.6	14.3	18.6	28	33.7	45	65
With cooling tube and bellows seal	PN16	6.8	7.4	7.9	10.9	13.1	16.9	25.3	30	40.3	58.3
	Pn40	7.3	7.9	8.4	11.9	14.6	18.9	28.3	34	45.3	65.3

baelz 342-2 dimensions (mm)				
DN	BL	h1	h2	
			342-2-B	342-2-BK, 342-2-BK-SS
15	130	75	110 (105)*	236 (231)*
20	150	75	110 (105)*	236 (231)*
25	160	85	110 (105)*	236 (231)*
32	180	100	104	283 (283)*
40	200	105	114	283 (281)*
50	230	115	124	293 (277)*
65	290	125	144	313 (269)*
80	310	130	154	323 (269)*
100	350	150	169	338 (262)*
125	400	200	189	358 (252)*

* Dimension h2 for previous version of baelz 342

baelz actuators dimensions (mm)					
Designation	L	x	Ød	l	ØD
E07	320	145	129		
E45	560	150	175		
E65	see dimensional drawing below				
P11				244	160
P21				268	242
P21-V6				304	242
P22				322	242

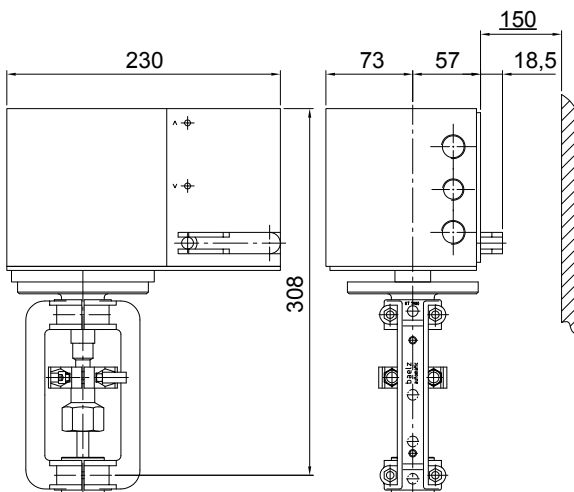

Dimensions of the baelz 373-E65 actuator

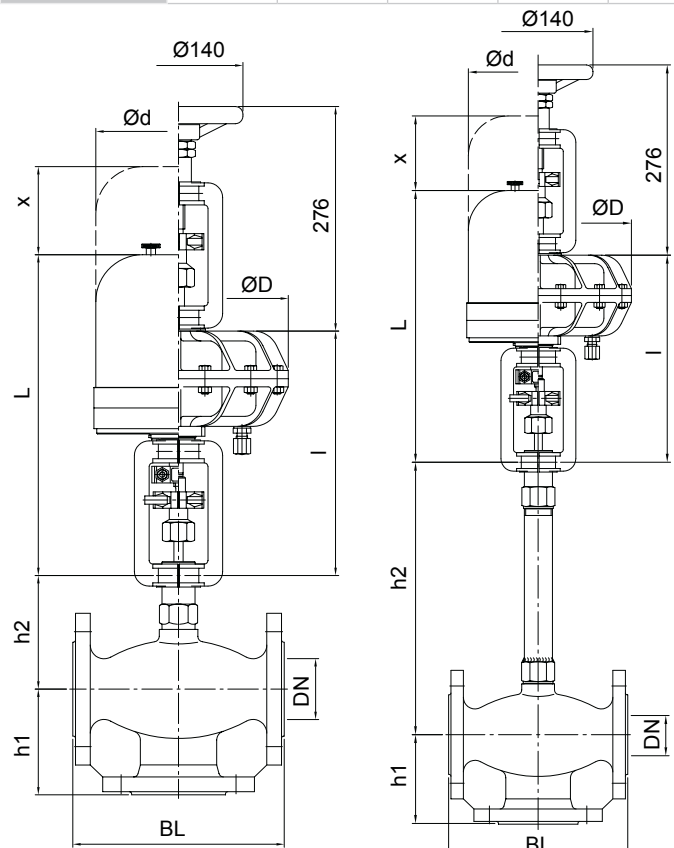

baelz 342-2-B DN15-125

baelz 342-2-BK DN15-125
baelz 342-2-BK-SS DN15-125

Maximum differential pressure ΔP_{max} (bar) at which the actuator closes the valve completely

The differential pressures specified here are limited by the nominal pressure of the housings, if this is lower.

Electric actuators. 3-way valves as mixing valves baelz 342-2-B, 342-2-BK, 342-2-BK-SS.

Plug closes against the flow.

Actuator baelz 373-	Power (N)	DN (mm) / maximum differential pressure ΔP_{max} (bar)														
		15	20	25	32	40	50	65	80	100	125	150	200	250	300	
E07- OSX-	700	14	14	10	5	2.5	1.2	0.3								
E07- 20-	2000	40	40	32	20	12	8	4.8	3	2	1.2					
E65- 11-	1100	25	25	21	11	6.3	3.5	1.7	0.9	0.3						
E65- 20-	2000	40	40	32	20	12	8	4.8	3	2	1.2					
E45- 40-	4000	40	40	40	40	25	16	10	6.9	4.4	2.8	1.7				
E66- 80-	8000												3.1	1.6	0.9	
E66- 150-	15000												7.1	3.8	2.3	1.5
E88- 100-	10000							28	18	11	7.4	5	2.7	1.7	1.1	
E88- 100-	13000							37	24	15	9.8	6.7	3.7	2.3	1.5	
E88- 100-	16000							40	30	19	12	8.4	4.6	2.9	2	
E88- 300-	30000												15.3	9	5.8	3.9
E88- 300-	35000												18.9	10.5	6.7	4.6
E88- 300-	40000												21.7	12.1	7.7	5.3

Electric actuators. 3-way valves as diverting valves baelz 342-2-B, 342-2-BK, 342-2-BK-SS.

Plug closes in direction of flow.

Actuator baelz 373-	Power (N)	DN (mm) / maximum differential pressure ΔP_{max} (bar)														
		15	20	25	32	40	50	65	80	100	125	150	200	250	300	
E07- OSX-	700	0.6	0.6	0.6	0.6	0.6	0.6									
E07- 20-	2000	0.6	0.6	0.6	0.6	0.6	0.6	0.6	0.6	0.6	0.6	0.6				
E65- 11-	1100	0.6	0.6	0.6	0.6	0.6	0.6	0.6	0.6	0.6	0.5					
E65- 20-	2000	0.6	0.6	0.6	0.6	0.6	0.6	0.6	0.6	0.6	0.6	0.6				
E45- 40-	4000	0.6	0.6	0.6	0.6	0.6	0.6	0.6	0.6	0.6	0.6	0.6				
E66- 150-	15000												1	0.6	0.6	0.6
E88- 100-	10000												1	0.6	0.6	0.6
E88- 300-	30000												1	0.6	0.6	0.6

Pneumatic actuators. 3-way valves as mixing valves baelz 342-2-B, 342-2-BK, 342-BK-SS.

Plug closes against the flow.

Actuator baelz 373-	Power (N)	req. feed pressure (bar)	DN (mm) / maximum differential pressure ΔP_{max} (bar)													
			15	20	25	32	40	50	65	80	100	125	150	200	250	300
P11- 1	950	6.0	18.6	18.6	13.9	5.6	3.4	1.9	0.9	0.4						
P21- 3	1020	1.2	7	7	4.5	2.8	1.7	1.1	0.7	0.4	0.3	0.2				
P21- 6	2040	3.0	40	40	33	20	13	8	5	3.3	2.1	1.3				
P21- 12	3390	6.0	40	40	40	35	22	14	8.5	5.6	3.6	2.3				
P21- 18	4030	6.0	40	40	40	40	27	17	10	7	4.3	2.7				
P21- V6	7590	6.0	40	40	29	18	11.5	7	4.3	2.8	1.8	1.2				
P31- 3	2480	1.2											0.6			
P31- 6	4960	3.0											2.3			
P31- 18	10560	6.0											5			
P41- 3	3765	1.2											2.4	1	0.6	0.4
P41- 6	7530	3.0											4.8	2	1.3	0.9
P41- V6	31920	6.0											8.2	3.5	2.3	1.6

Pneumatic actuators. 3-way valves as diverting valves baelz 342-2-B, 342-2-BK, 342-2-BK-SS.

Plug closes in direction of flow.

Actuator baelz 373-	Power (N)	req. feed pressure (bar)	DN (mm) / maximum differential pressure ΔP_{max} (bar)													
			15	20	25	32	40	50	65	80	100	125	150	200	250	300
all		1.2 - 6.0	Deploy all diverting valves only up to 0.6 bar differential pressure. If a diverting valve with > 0.6 bar is required, valve with > 0.6 bar is required, a damping device must be provided on the actuator.													

Sectional drawings of the baelz 342-2 plug

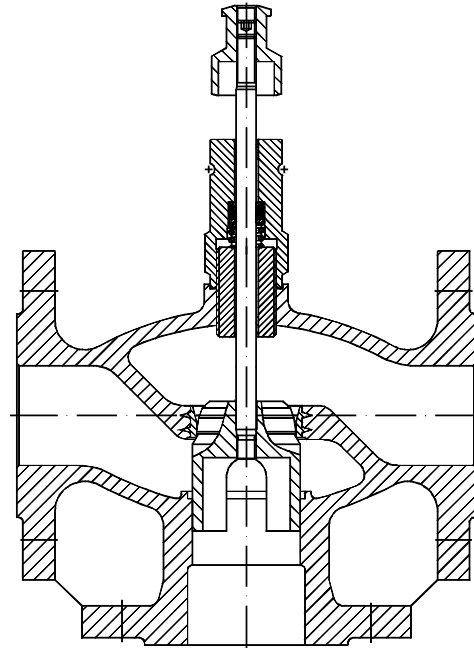

Mixing plug with slot guides
baelz 342-2-B

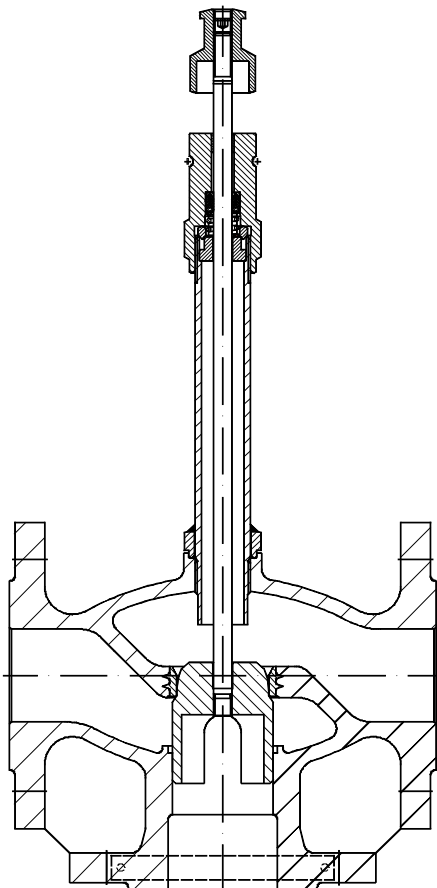

Mixing plug with slot guides
baelz 342-2-BK

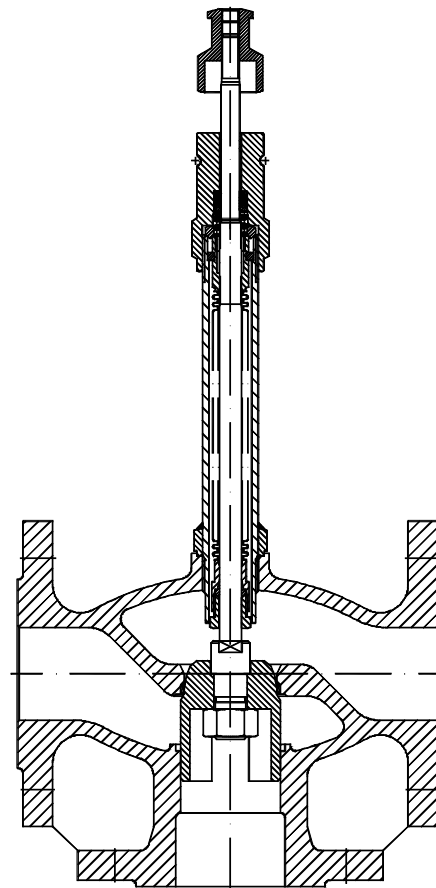

baelz 342-2-BK-SS reinforced mixing plug
with slot guides



baelz 347 & 347-2

DESCRIPTION

The baelz 347-2-B is a universal 3-way valve for industrial applications. The variety of plug variants and the highly precise tightness tolerances allow utilization of the valve for the solution of complicated control tasks.

TECHNICAL SPECIFICATIONS

Connection type: Flange EN 1092-2; EN 1092-1 Shapes D / E / F on request.
 Plug type: parabolic plug with slit
 Control characteristic: linear
 Working fluids: steam, gas, liquids, thermal oil

Leakage class (EN 1349)
metal-to-metal seal: 0.004% Kvs (better than class IV)
with PTFE plug: 0.001% Kvs (better than class VI)

Stroke (mm)		Spindle diameter (mm)
DN 15-25	12	10
DN 32-125	22	
DN 150	44	
DN 200-250 (DN 300 and 350 on request)	66	22

Options		Designation*
Plug	Parabolic plug (standard)	baelz 347-2-B
	Cage plug	MP347-LK
	Balanced	baelz 347-2-B-EMF
	Reduced Kvs	MP347-Skr...
Spindle seal	V-rings in PFTE (standard)	baelz 347-2-B
	Cooling tube	baelz 347-2-BK
	Stainless steel bellows seal + safety gland	baelz 347-2-BK-SS
Flanges	Flange facing: groove all sides	MP347-ALL-N...
Additional options	V-shaped seal heating (for fluids at temperatures of - 10 to - 40°C) Pmax. 20 W; 12-24 V / 110-230 V AC/DC	baelz 85950...
	Construction without silicone	MP347-Silf...

* Designation: 347-2-B up to DN 125 and spindle Ø 10 mm; 347-BB from DN 150 and spindle Ø 22 mm

Housing material	T max. (°C) / P max. (bar)		
	Spheroid ductile iron GJS-400-18-LT - 5.3103		Cast steel GP240GH - 1.0619
Nominal pressure	PN 16	PN 25	PN 40
baelz 347-2-B, 347-BB	240/14 ... 50/16	240/22 ... 50/25	-
baelz 347-2-BK, 347-BBK	350/11.2 ... 50/16	350/17.5 ... 50/25	350/25.7 ... 50/40
baelz 347-2-BK-SS, 347-BBK-SS	350/11.2 ... 50/16	-	350/25 ... 50/25
baelz 347-2-BK-EMF, 347-BBK-EMF	260/13.6 ... 50/16	260/21.4 ... 50/25	260/29.8 ... 50/40
baelz 347-2-BK-EMF-HG, 347-BBK-EMF-HG	315/12.3 ... 50/16	315/19.2 ... 50/25	315/27 ... 50/40

Note: As we are constantly improving our products, there is more than one series of this article. When ordering spares or parts for an existing system, please state the old serial numbers and, if in doubt, contact Baelz. We'll be pleased to help.

DN	Kvs value (m³/h)													
	15	20	25	32	40	50	65	80	100	125	150	200	250	300
Standard (B/BB/BK)	5.9	7.8	9.6	16	25	36	63	105	130	200	360	580	960	1340
Balanced (EMF)	-				25	36	63	105 / 75	130 / 105	200 / 150	360	580	960	1340
Cage plug (LK)	2.5	4	6.3	12.5	20	32	50	80	100	130	250	320	580	960
	2	3.2	5	10	16	25	40	63	80	100				
	1.6	2.5	4	6.3	10	16	25	40	63					
Reduced (Skr)	2	2.5	5	8	12.5	20	32	50	80	130			-	
	1	1.6	3.2	4	6.3	10	16	25	40	63			-	

Kvs values given in this form: XX/YY, denote Kvs values for the straight way (XX) and the angle way (YY)

Utilization conditions for plugs in baelz 347 & 347-2 valves				
Valve function	Actuator type	Pressure difference at the plug (bar)	Nominal diameter	Plug type
Flow separation	Electric actuator	≤0.6	DN 15 - 350	without restrictions
		>0.6	DN 15 - 32	without restrictions
		>0.6	DN 40 - 350	Balanced (EMF)*
	Pneumatic actuator	≤0.6	DN 15 - 350	without restrictions
		>0.6	DN 15 - 32	on request
		>0.6	DN 40 - 350	Balanced (EMF)
Flow mix	without restrictions			

* Baelz will be pleased to inform you about possible applications with other plug variants

Approximate weights of the baelz 347 & 347-2 valves without actuator (kg)															
DN	15	20	25	32	40	50	65	80	100	125	150	200	250	300	350
347-2-B/ 347-BB Spheroid ductile iron	PN 16						24		39	57			240	on request	on request
	PN 25	5.5	6.1	6.6	9.6	11.8	15.6	-	28.7	-	-	90	200	-	-
347-BB Cast steel	PN 40	-	-	-	-	-	-	-	-	-	-	108	250	338	-
347-2-BK/ 347-BBK Spheroid ductile iron	PN 16													300	on request
	PN 25	6.5	7.1	7.6	10.6	12.8	16.6	25	29.7	40	58	96	250	-	-
347-2-BK/ 347-BBK Cast steel	PN 25	-	-	-	-	-	-	-	-	-	-	-	-	335	-
	PN 40	7	7.6	8.1	11.6	14.3	18.6	28	33.7	45	65	114	265	353	-
347-2-BK/ 347-BBK-SS	PN 16	6.8	7.4	7.9	10.9	13.1	16.9	25.3	30	40.3	58.3	96.7	250	300	-
	PN 40	7.3	7.9	8.4	11.9	14.6	18.9	28.3	34	45.3	65.3	115	266	-	-

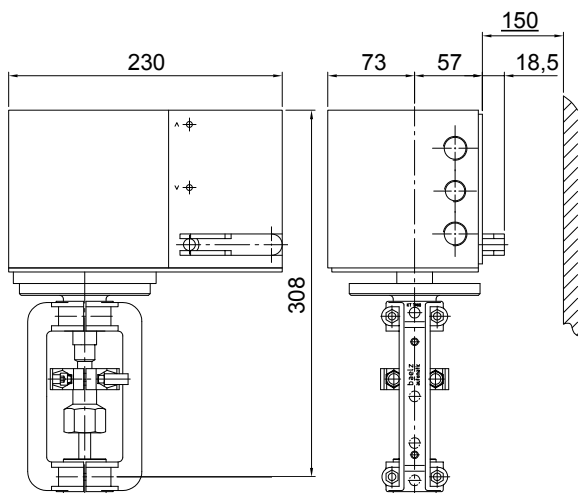

Dimensions of the baelz 373-E65 actuator

baelz 347 & 347-2 dimensions (mm)				
DN	BL	h1	h2	
			347-2-B, 347-2-B-EMF	347-2-BK, 347-2-BK-SS
15	130	75	110 (was 105)*	236 (was 231)*
20	150	75	110 (was 105)*	236 (was 231)*
25	160	85	110 (was 105)*	236 (was 231)*
32	180	100	104	283 (was 283)*
40	200	105	114	283 (was 281)*
50	230	115	124	293 (was 277)*
65	290	125	144	313 (was 269)*
80	310	130	154	323 (was 269)*
100	350	150	169	338 (was 262)*
125	400	200	189	358 (was 252)*
DN	BL	h1	347-2-BB, 347-BB-EMF	347-BBK, 347-BBK-SS
150	480	240	244 (324)	234
200	600	381	268 (348)	258
250	730	427	317 (397)	307
300	850	288	361 (441)	351

* Dimension h2 for previous baelz 347version

Dimensions of the baelz actuators (mm)					
Designation	L	x	Ød	I	ØD
E07	320	145	129		
E45	560	150	175		
E65	see dimensional drawing on previous page				
P11				244	160
P21				268	242
P21-V6				304	242
P22				322	242
	347-BB/ BB-EMF	347-BBK/ BBK-SS		347-BB/ BB-EMF	347-BBK/ BBK-SS
E45	577	1057	150	175	
E66	614	1094	200	188 (258*)	
P31				509	989 384
P32				525	1005 384
P41				562	1042 506
P41-V6				687	1167 506

Electric actuators: baelz 373-E

Pneumatic actuators: baelz 373-P

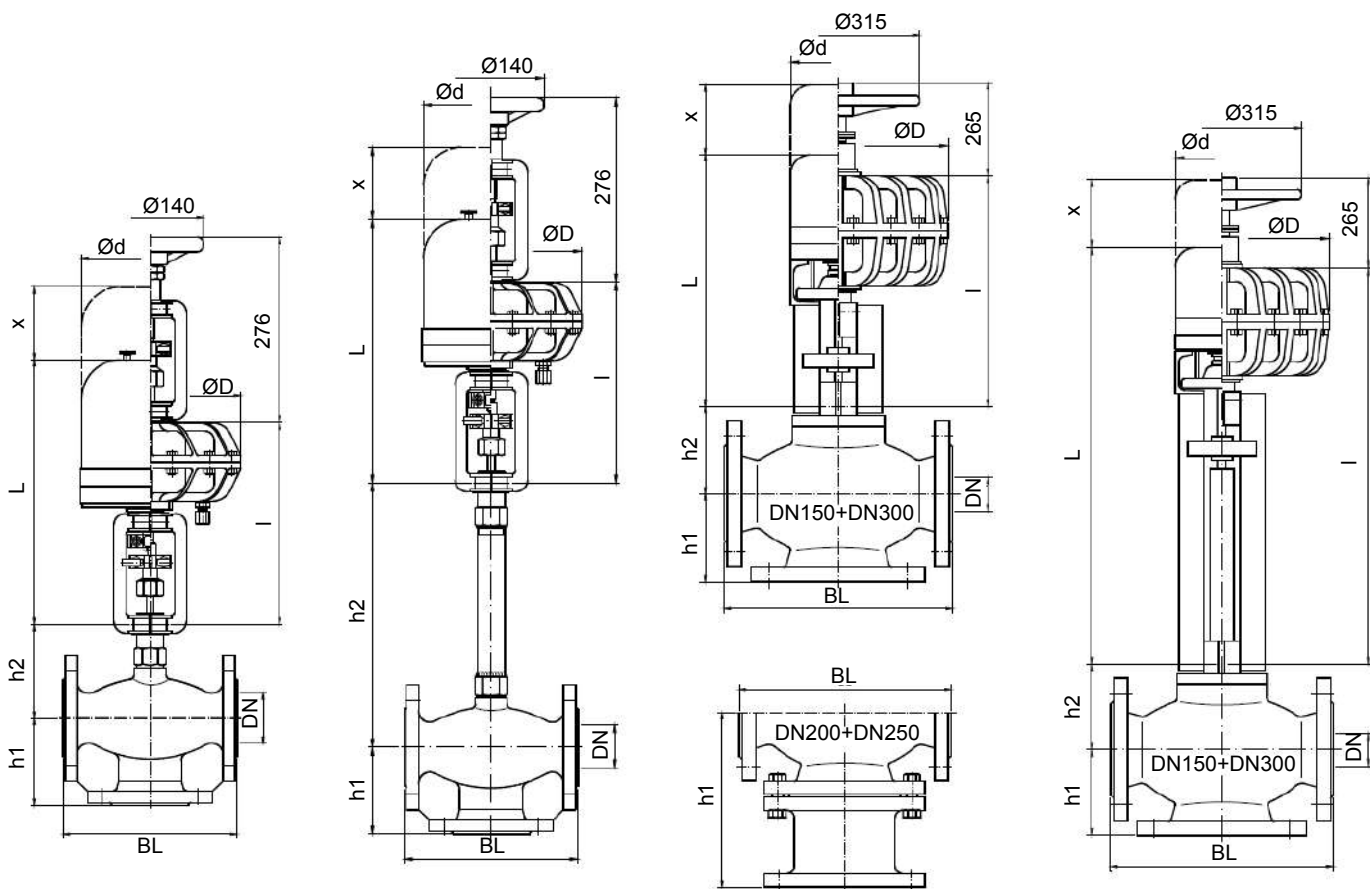

baelz 347-2-B DN15-125
baelz 347-2-B-EM DN50-125

baelz 347-2-BK DN15-125
baelz 347-2-BK-SS DN15-125

baelz 347-BB DN150-300
baelz 347-BB-EM DN150-300

baelz 347-BBK DN150-300
baelz 347-BBK-SS DN150-300

EN_MJ_0221

Maximum differential pressure ΔP_{max} (bar) at which the actuator closes the valve completely

The differential pressures specified here are limited by the nominal pressure of the housings, if this is lower.

Electric actuators. 3-way valves as mixing valves baelz 347-2-B/347-BB, 347-2-BK/347-BBK, 347-2-BK-SS/347-BBK-SS.

Plug closes against the flow.

Actuator baelz 373-	Power (N)	DN (mm) / maximum differential pressure ΔP_{max} (bar)														
		15	20	25	32	40	50	65	80	100	125	150	200	250	300	
E07- OSX-	700	14	14	10	5	2.5	1.2	0.3								
E07- 20-	2000	40	40	32	20	12	8	4.8	3	2	1.2					
E65- 11-	1100	25	25	21	11	6.3	3.5	1.7	0.9	0.3						
E65- 20-	2000	40	40	32	20	12	8	4.8	3	2	1.2					
E45- 40-	4000	40	40	40	40	25	16	10	6.9	4.4	2.8	1.7				
E66- 80-	8000												3.1	1.6	0.9	
E66- 150-	15000												7.1	3.8	2.3	1.5
E88- 100-	10000							28	18	11	7.4	5	2.7	1.7	1.1	
E88- 100-	13000							37	24	15	9.8	6.7	3.7	2.3	1.5	
E88- 100-	16000							40	30	19	12	8.4	4.6	2.9	2	
E88- 300-	30000											15.3	9	5.8	3.9	
E88- 300-	35000											18.9	10.5	6.7	4.6	
E88- 300-	40000											21.7	12.1	7.7	5.3	

Electric actuators. 3-way valves as diverting valves baelz 347-2-B/347-BB, 347-2-BK/347-BBK, 347-2-BK-SS/347-BBK-SS.

Plug closes in direction of flow.

Actuator baelz 373-	Power (N)	DN (mm) / maximum differential pressure ΔP_{max} (bar)														
		15	20	25	32	40	50	65	80	100	125	150	200	250	300	
E07- OSX-	700	0.6	0.6	0.6	0.6	0.6	0.6									
E07- 20-	2000	0.6	0.6	0.6	0.6	0.6	0.6	0.6	0.6	0.6	0.6	0.6				
E65- 11-	1100	0.6	0.6	0.6	0.6	0.6	0.6	0.6	0.6	0.6	0.6	0.5				
E65- 20-	2000	0.6	0.6	0.6	0.6	0.6	0.6	0.6	0.6	0.6	0.6	0.6				
E45- 40-	4000	0.6	0.6	0.6	0.6	0.6	0.6	0.6	0.6	0.6	0.6	0.6				
E66- 150-	15000												1	0.6	0.6	0.6
E88- 100-	10000												1	0.6	0.6	0.6
E88- 300-	30000												1	0.6	0.6	0.6

Electric actuators. Balanced 3-way valves as mixing valves and diverting valves for liquids and steam

baelz 347-2-B-EMF, 347-BB-EMF.

Actuator baelz 373-	Power (N)	DN (mm) / maximum differential pressure ΔP_{max} (bar)														
		15	20	25	32	40	50	65	80	100	125	150	200	250	300	
E07- OSX-	700					12.5	7.5	3.2	0.4							
E07- 20-	2000					40	40	29.2	21.4	12.1	4.2					
E65- 11-	1100					20.3	14	7.8	3.9							
E65- 20-	2000					40	40	29.2	21.4	12.1	4.2					
E45- 40-	4000					40	40	40	40	40	26.7	6.5				
E66- 80-	8000												19.7	13.2	8.7	5.7
E66- 150-	15000												40	35.2	26.2	20.3
E63- 440-	4448												8.2			
E88- 100-	10000												29	21.5	14.6	10.6
E88- 100-	13000												40	31.1	21.6	16.4
E88- 100-	16000												40	40	28.6	22.3
E88- 300-	30000												40	40	40	40
E88- 300-	35000												40	40	40	40
E88- 300-	40000												40	40	40	40

Maximum differential pressure ΔP_{max} (bar) at which the actuator closes the valve completely

The differential pressures specified here are limited by the nominal pressure of the housings, if this is lower.

Pneumatic actuators. 3-way valves as mixing valves baelz 347-2-B/347-BB, 347-2-BK/347-BBK, 347-2-BK-SS/347-BBK-SS. Plug closes against the flow.

Actuator baelz 373-	Power (N)	req. feed pressure (bar)	DN (mm) / maximum differential pressure ΔP_{max} (bar)															
			15	20	25	32	40	50	65	80	100	125	150	200	250	300		
P11- 1	950	6.0	18.6	18.6	13.9	5.6	3.4	1.9	0.9	0.4								
P21- 3	1020	1.2	7	7	4.5	2.8	1.7	1.1	0.7	0.4	0.3	0.2						
P21- 6	2040	3.0	40	40	33	20	13	8	5	3.3	2.1	1.3						
P21- 12	3390	6.0	40	40	40	35	22	14	8.5	5.6	3.6	2.3						
P21- 18	4030	6.0	40	40	40	40	27	17	10	7	4.3	2.7						
P21- V6	7590	6.0	40	40	29	18	11.5	7	4.3	2.8	1.8	1.2						
P31- 3	2480	1.2														0.6		
P31- 6	4960	3.0														2.3		
P31- 18	10560	6.0														5		
P41- 3	3765	1.2													2.4	1	0.6	0.4
P41- 6	7530	3.0													4.8	2	1.3	0.9
P41- V6	31920	6.0													8.2	3.5	2.3	1.6

Pneumatic actuators. Balanced 3-way valves as mixing valves and diverting valves for liquids and steam baelz 347-2-B-EMF, 347-BB-EMF.

Actuator baelz 373-	Power (N)	req. feed pressure (bar)	DN (mm) / maximum differential pressure ΔP_{max} (bar)																
			15	20	25	32	40	50	65	80	100	125	150	200	250	300			
P11- 1	950	6.0						19.3	13.2	7.4									
P21- 3	1020	1.2						21	14.6	8.2	4.2								
P21- 6	2040	3.0						40	40	30	22	12.7	4.6						
P22- 3	1846	3.0						40	37.4	25.9	18.7	10	2.4						
P22- 6	3692	6.0						40	40	40	40	35.8	23.3						
P31- 3	2480	3.0														0.8			
P31- 6	4960	3.0														10.1			
P31- 18	10560	6.0														31.1			
P32- 6	4402	3.0														4.3	1.5		
P32- 18	8115	6.0														15	10.1	6.9	
P41- 3	3765	1.2														5.6	2.2		
P41- 6	7530	3.0														19.8	13.2	8.8	5.8
P41- V6	31920	6.0														40	40	40	40

Pneumatic actuators. 3-way valves as diverting valves baelz 347-2-B/347-BB, 347-2-BK/347-BBK, 347-2-BK-SS/347-BBK-SS. Plug closes in direction of flow.

Actuator baelz 373-	Power (N)	req. feed pressure (bar)	DN (mm) / maximum differential pressure ΔP_{max} (bar)													
			15	20	25	32	40	50	65	80	100	125	150	200	250	300
all		1.2 - 6.0	Deploy all diverting valves only up to 0.6 bar differential pressure. If a diverting valve with > 0.6 bar is required, valve with > 0.6 bar is required, a damping device must be provided on the actuator.													

Sectional drawings of the baelz plug 347 & 347-2

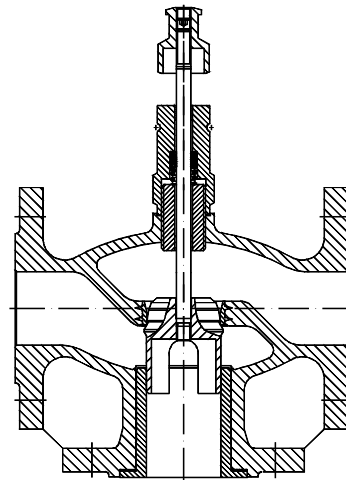

Mixing plug
with slot guides
baelz 347-2-B

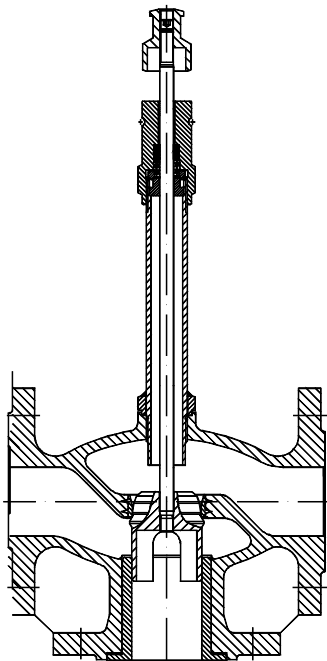

Mixing plug
with slot guides
baelz 347-2-BK

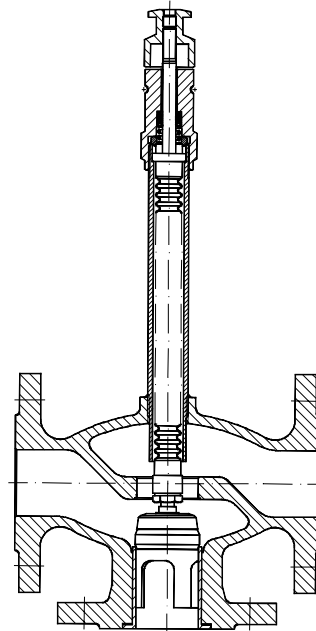

Reinforced plug
with slot guides
baelz 347-2-BK-SS

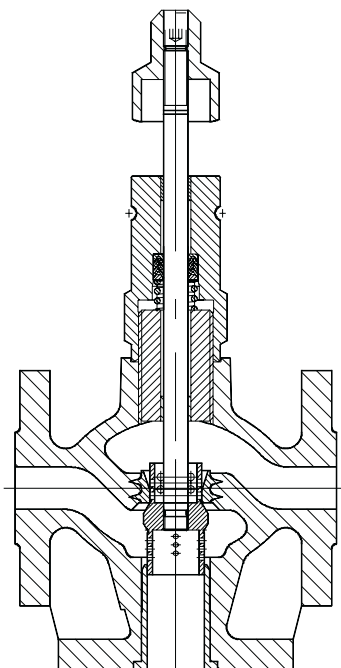

baelz 347-2 mixing
cage plug

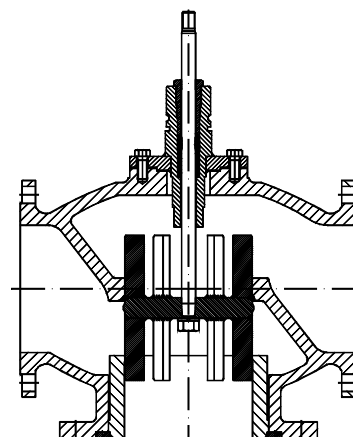

baelz 347-BB mixing slit
plug

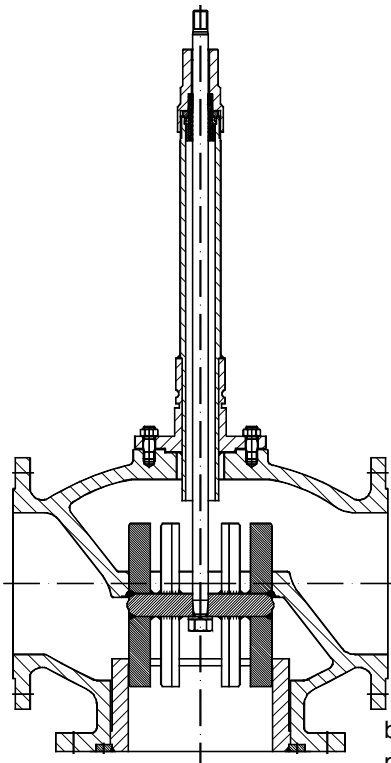

baelz 347-BBK mixing slit plug

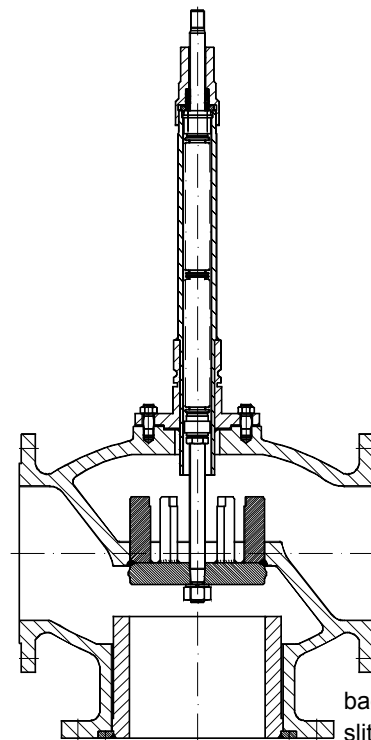

baelz 347-BBK-SS mixing slit plug

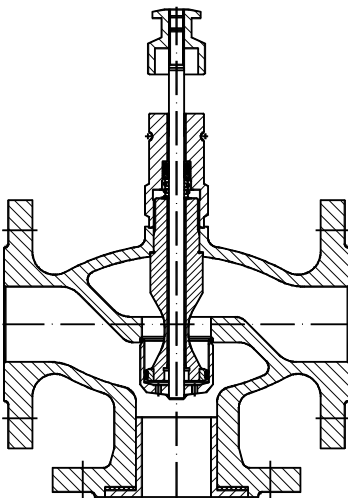

baelz 347-2-B-EM balanced universal plug

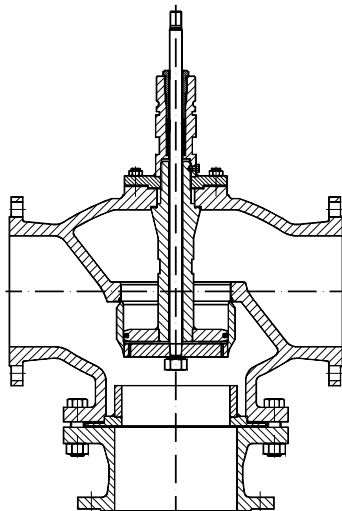

Balanced universal plug
baelz 347-BB-EMF
DN200+250

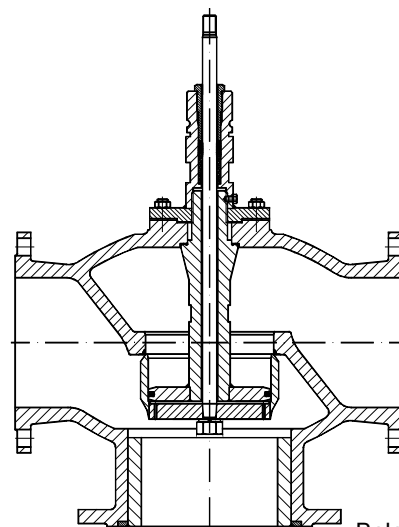

Balanced universal plug
baelz 347-BB-EM
DN150-300



baelz 353 / 354

DESCRIPTION

baelz 353 and baelz 354 are industrial 3-way control valves. The stainless steel housing allows utilization under demanding operating conditions.

TECHNICAL SPECIFICATIONS

Connection type: Flange EN 1092-2; EN 1092-1 Shapes D / E / F on request.
 Type of plug: parabolic plug with slot
 Control characteristic: linear
 Working fluids: liquids, water, thermal oil, steam, gases

Leakage class (EN 1349)	
Straight way (A-AB)	0.004 % Kvs (better than class IV)
Angle way (B-AB)	0.004 % Kvs (better than class IV)

Stroke (mm)			Spindle Ø (mm)
baelz 353	DN 15-25	12	10
baelz 353	DN 32-65*	22	
baelz 354	DN 80-125*	22	

* DN 150 with stroke 44 mm on request

Options		Designation
Plug	Parabolic plug with slot	baelz 353 / baelz 354
Spindle seal	V-rings in PTFE (standard)	baelz 353 / baelz 354
Additional options	Cooling tube	MP353-...-K / MP354-...-K
	V-shaped seal heating (for fluids at temperatures of - 10 to - 40°C) Pmax. 20 W; 12-24 V / 110-230 V AC/DC	baelz 85950...
	Version suitable for drinking water	MP353-Twg

Baelz Type	T max. (°C) / P max. (bar)		
	baelz 353	baelz 354	
Housing material	X6CrNiMoTi17-12-2 - 1.4571	GX5CrNiMo19-11 - 1.4408	
Nominal pressure	PN 16 / 25 / 40	PN 16	PN 25 / PN 40
Standard model	240 / 35.7 ... 100 / 40	240 / 12.8 ... 100 / 16	240 / 32.1 ... 100 / 40
with cooling tube	350 / 32.1 ... 100 / 40	350 / 11.4 ... 100 / 16	350 / 28.5 ... 100 / 40

baelz 353 / 354 Kvs values and weights																
Baelz Type	baelz 353							baelz 354								
	DN 15	20	25	32	40	50	65	80	100	125	150*	65	80	100	125	150*
PN	PN 16 / 25 / 40							PN 16			PN 25 / PN 40					
Kvs (m³/h)	5.6/ 5	7/ 6	9/ 8	15/ 13.5	25/ 22	42/ 36	63/ 55	100/ 90	130/ 115	200/ 180	360/ 320	63/ 55	100/ 90	130/ 115	200/ 180	360/ 320
Weight approx. (kg)	5.5	6.1	6.6	12.4	15.3	19.8	29.6	35.8	48.8	70.6	108	29.6	36.8	50.8	73.6	111

* DN 150 on request

Note: Kvs values given in this form: XX/YY, denote Kvs values for the straight way (XX) and the angle way (YY)

baelz 353 / 354 dimensions (mm)					
Baelz Type	DN	BL	h1	h2	
				353 354	353-K 354-K
baelz 353	15	130	89	105	268
	20	150	89	105	268
	25	160	89	105	268
	32	180	160	145	381
	40	200	160	145	381
	50	230	170	150	386
baelz 354	65	290	180	154	390
	80	310	190	157	393
	100	350	200	165	401
	125	400	220	175	411

baelz actuators dimensions (mm)					
Designation	L	x	Ød	l	ØD
E07	320	145	129		
E45	560	150	175		
P11				244	160
P21				268	242
P21-V6				304	242
P22				322	242

Electric actuators: baelz 373-E
Pneumatic actuators: baelz 373-P

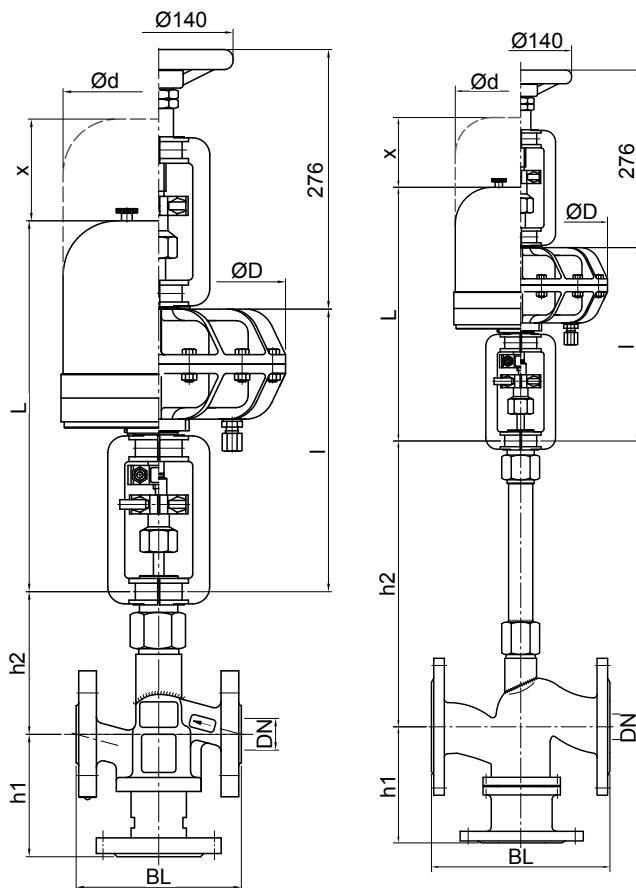

baelz 353 DN 15-65
baelz 354 DN 80-125

baelz 353-K DN 15-65
baelz 354-K DN 80-125

Sectional drawings of the baelz plug 353 / 354

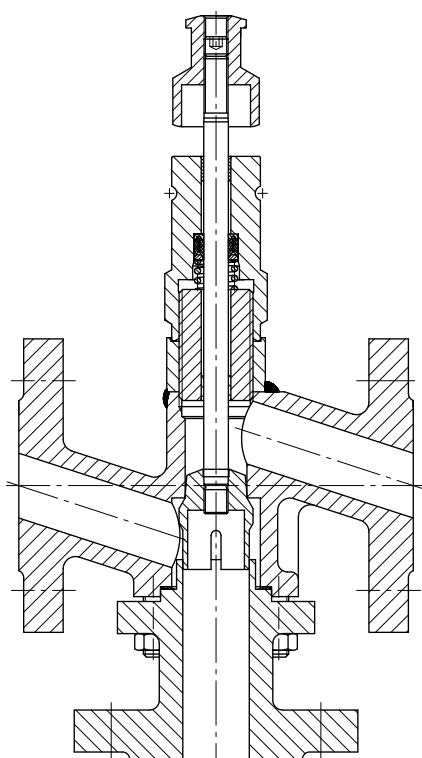

Parabolic plug with slot
baelz 353 DN 15-65

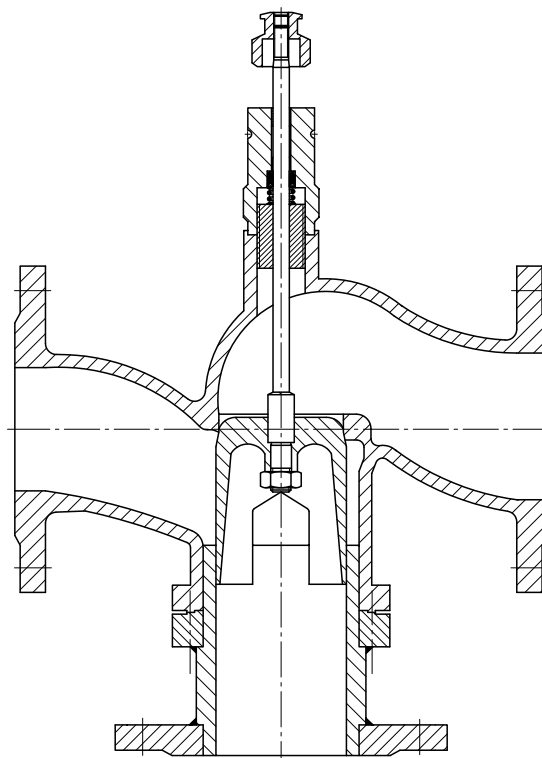

Parabolic plug with slot
baelz 354 DN 80-125



Maximum differential pressure ΔP_{max} (bar) at which the actuator closes the valve completely
 The differential pressures specified here are limited by the nominal pressure of the housings, if this is lower.

Electric actuators. 3-way valves as mixing valves. Plug closes against the flow.

Actuator baelz 373-	Power (N)	DN (mm) / maximum differential pressure ΔP_{max} (bar)														
		15	20	25	32	40	50	65	80	100	125	150	200	250	300	
E07- OSX-	700	14	14	10	5	2.5	1.2	0.3								
E07- 20-	2000	40	40	32	20	12	8	4.8	3	2	1.2					
E65- 11-	1100	25	25	21	11	6.3	3.5	1.7	0.9	0.3						
E65- 20-	2000	40	40	32	20	12	8	4.8	3	2	1.2					
E45- 40-	4000	40	40	40	40	25	16	10	6.9	4.4	2.8	1.7				
E66- 80-	8000											3.1	1.6	0.9		
E66- 150-	15000											7.1	3.8	2.3	1.5	
E88- 100-	10000							28	18	11	7.4	5	2.7	1.7	1.1	
E88- 100-	13000							37	24	15	9.8	6.7	3.7	2.3	1.5	
E88- 100-	16000							40	30	19	12	8.4	4.6	2.9	2	
E88- 300-	30000											15.3	9	5.8	3.9	
E88- 300-	35000											18.9	10.5	6.7	4.6	
E88- 300-	40000											21.7	12.1	7.7	5.3	

Pneumatic actuators. 3-way valves as mixing valves. Plug closes against the flow.

Actuator baelz 373-	Power (N)	req. feed pressure (bar)	DN (mm) / maximum differential pressure ΔP_{max} (bar)													
			15	20	25	32	40	50	65	80	100	125	150	200	250	300
P11- 1	950	6.0	18.6	18.6	13.9	5.6	3.4	1.9	0.9	0.4						
P21- 3	1020	1.2	7	7	4.5	2.8	1.7	1.1	0.7	0.4	0.3	0.2				
P21- 6	2040	3.0	40	40	33	20	13	8	5	3.3	2.1	1.3				
P21- 12	3390	6.0	40	40	40	35	22	14	8.5	5.6	3.6	2.3				
P21- 18	4030	6.0	40	40	40	40	27	17	10	7	4.3	2.7				
P21- V6	7590	6.0	40	40	29	18	11.5	7	4.3	2.8	1.8	1.2				
P31- 3	2480	1.2											0.6			
P31- 6	4960	3.0											2.3			
P31- 18	10560	6.0											5			
P41- 3	3765	1.2											2.4	1	0.6	0.4
P41- 6	7530	3.0											4.8	2	1.3	0.9
P41- V6	31920	6.0											8.2	3.5	2.3	1.6



Leakage class (EN 1349)

metal-to-metal seal: 0.004% Kvs (better than class IV)

baelz 367 & 367-2

DESCRIPTION

The baelz 367 / 367-2 ANSI 300 valve is a flanged and pressure rated 3-way control valve in accordance with US ANSI / ASME standards.

TECHNICAL SPECIFICATIONS

Connection type: ASME / ANSI B16.5 flange

Plug type: parabolic plug

Control characteristic: equal percentage

Working fluids: liquids, gases, water, steam, thermal oil

For NPS 1 1/2" - 4", designation = baelz 367-2

For NPS 6", designation = baelz 367

Other sizes available on request.

Technical Specifications		Designation
Housing material	1.0619 (1.0432) / SA216WCB (SA105)	baelz 367-2... / baelz 367...
T max. / P max.	450 °F/620 psi; 100 °F/740 psi 232 °C/42,7 bar; 38 °C/51.1 bar	baelz 367-2...
	650 °F/550 psi; 100 °F/740 psi 343 °C/37,9 bar; 38 °C/51.1 bar	baelz 367-2-K...
	650 °F/362 psi; 100 °F/362 psi 343 °C/25 bar; 38 °C/25 bar	baelz 367-K-SS...
Plug	Parabolic plug (standard)	baelz 367-2... / baelz 367...
Cooling tube / Spindle seal	V-rings in PTFE standard	baelz 367-2... / baelz 367...
	Cooling tube	baelz 367-2-K...
	Cooling tube + double-wall stainless steel bellows and safety gland	baelz 367-2-K-SS... / baelz 367-K-SS...
Additional options	V-shaped seal heating (for fluids at temperatures of - 10 to - 40°C) Pmax. 20 W; 12-24 V / 110-230 V AC/DC	baelz 85950...

baelz 367 & 367-2 ANSI 300 valve stroke, seat diameter and Kvs values						
NPS	1 1/2"	2"	2 1/2"	3"	4"	6"
Stroke (")	0.87	0.87	0.87	0.87	0.87	1.73
Seat Ø (")	1.57	1.97	2.55	3.15	3.93	5.9
Cv (US GPM)	29.2	42.0	73.5	122.6	165.8	420
Nominal diameter, DN (mm)	40	50	65	80	100	150
Stroke (mm)	22	22	22	22	22	44
Seat Ø (mm)	40	50	65	80	100	150
Kvs value (m³/h)	25	36	63	105	142	360

Note: As we are constantly improving our products, there is more than one series of this article. When ordering spares or parts for an existing system, please state the old serial numbers and, if in doubt, contact Baelz. We'll be pleased to help.

Actuator	L		x		Ød		l		ØD	
	inches	mm	inches	mm	inches	mm	inches	mm	inches	mm
E07	12.60	320	5.71	145	5.0	129				
E 45	13.66	347	5.9	150	6.81	173				
E 65	12.17	309	-	-	9.06	230 wide*				
E 66	24.17/43.19 ⁺	614/1094 ⁺	7.87	200	7.40	188				
P 21							10.6	268	9.5	242
P 21-V6							11.9	304	9.5	242

⁺ with yoke S41/with yoke S41C

* dimensions, see datasheet of actuator E65

baelz 367-K-SS & 367-2-K-SS approximate dimensions and weights									
NPS / DN		BL		h1		h2		weight	
in.	mm	in.	mm	in.	mm	in.	mm	lbs	kg
1 1/2"	40	9.25	235	4.63	117.5	11.14	283	26.1	11.8
2"	50	10.51	267	5.25	133.5	11.54	293	40.1	18.2
2 1/2"	65	11.5	292	5.75	146	12.32	313	54.7	24.8
3"	80	12.52	318	6.25	159	12.72	323	69.7	31.6
4"	100	14.49	368	7.25	184	13.31	338	115	51.9
6"	150	17.62	473	8.81	236.5	on request		241	110

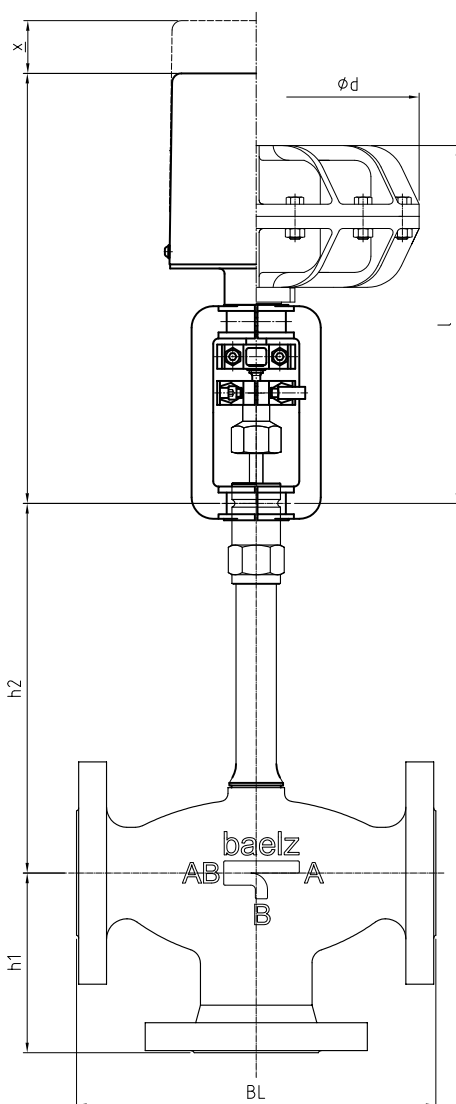

Maximum differential pressure ΔP_{max} (bar) at which the actuator closes the valve completely
 The differential pressures specified here are limited by the nominal pressure of the housings, if this is lower.

Electric actuators. 3-way valves as mixing valves. Plug closes against the flow.

Actuator baelz 373-	Power (N)	DN (mm) / maximum differential pressure ΔP_{max} (bar)						
		40	50	65	80	100	125	150
E07- OSX	700	2.5	1.2	0.3				
E07- 20-	2000	12	8	4.8	3	2	1.2	
E65- 11-	1100	6.3	3.5	1.7	1.5	1	0.6	
E65- 20-	2000	12	8	4.8	3	2	1.2	
E45- 40-	4000	25	16	10	6.9	4.4	2.8	1.7
E66- 80-	8000							3.1
E66- 150-	15000							7.1
E88- 100-	10000			28	18	11	7.4	5
E88- 100-	13000			37	24	15	9.8	6.7
E88- 100-	16000			40	30	19	12	8.4
E88- 300-	30000							15.3
E88- 300-	35000							18.9
E88- 300-	40000							21.7

Electric actuators. 3-way valves as diverting valves. Plug closes in direction of flow.

Actuator baelz 373-	Power (N)	DN (mm) / maximum differential pressure ΔP_{max} (bar)						
		40	50	65	80	100	125	150
E07- OSX	700	0.6	0.6					
E07- 20-	2000	0.6	0.6	0.6	0.6	0.6	0.6	
E65- 11-	1100	0.6	0.6	0.6	0.6	0.6	0.5	
E65- 20-	2000	0.6	0.6	0.6	0.6	0.6	0.6	
E45- 40-	4000	0.6	0.6	0.6	0.6	0.6	0.6	
E66- 150-	15000							1
E88- 100-	10000							1
E88- 300-	30000							1

Pneumatic actuators. 3-way valves as mixing valves. Plug closes against the flow.

Actuator baelz 373-	Power (N)	req. feed press. (bar)	DN (mm) / maximum differential pressure ΔP_{max} (bar)						
			40	50	65	80	100	125	150
P11- 1	950	6.0	3.4	1.9	0.9	0.4			
P21- 3	1020	1.2	1.7	1.1	0.7	0.4	0.3	0.2	
P21- 6	2040	3.0	13	8	5	3.3	2.1	1.3	
P21- 12	3390	6.0	22	14	8.5	5.6	3.6	2.3	
P21- 18	4030	6.0	27	17	10	7	4.3	2.7	
P21- V6	7590	6.0	11.5	7	4.3	2.8	1.8	1.2	
P31- 3	2480	1.2							0.6
P31- 6	4960	3.0							2.3
P31- 18	10560	6.0							5
P41- 3	3765	1.2							2.4
P41- 6	7530	3.0							4.8
P41- V6	31920	6.0							8.2

Pneumatic actuators. 3-way valves as diverting valves. Plug closes in direction of flow.

Actuator baelz 373-	Power (N)	req. feed press. (bar)	DN (mm) / maximum differential pressure ΔP_{max} (bar)						
			40	50	65	80	100	125	150
all		1.2 - 6.0	All diverting valves may only be utilized up to 0.6 bar differential pressure. If a diverting valve with > 0.6 bar is required, a damping device must be provided on the actuator.						

1.7 Table of Kvs values for 2-way and 3-way control valves



DN	185	192	334 335	340-2	340-2- EMF	342-2 347-2	344 344-EMF	346- EMB	346-22	347-2- EMF	353 354	356	358 359	360-EM-C 360-EM-CC	365 367
15	0.025	5.0	3.5	1.0	-	1.0	-	-	-	-	5.6 / 5	1.0	3.8	-	-
	0.04	LK 1.3		2.0		2.0						2.0			
	0.10	LK 2.0		3.0		3.0						3.8			
	0.12	LK 2.5		5.9		5.9						LK 1.6			
	0.16			LK 1.6		LK 1.6						LK 2.0			
	0.30			LK 2.0		LK 2.5						LK 2.5			
	0.60			LK 2.5		LK 2.0									
	1.00														
1.20															
1.40															
20	-	6.0	5.0	1.6	-	1.6	-	-	-	-	7 / 6	2.0	7.3	-	-
		LK 1.6		2.5		2.5						4.0			
		LK 2.5		7.8		7.8						7.3			
		LK 3.2		LK 2.5		LK 2.5						LK 2.5			
				LK 3.2		LK 3.2						LK 3.2			
25	-	8.0	9.0	3.2	-	3.2	-	-	-	-	9 / 8	4.0	9.3	-	-
		LK 2.5		5.0		5.0						6.4			
		LK 4.0		9.6		9.6						8.3			
				LK 4.0		LK 4.0						9.3			
				LK 5.0		LK 5.0						LK 4.0			
				LK 6.3		LK 6.3						LK 5.0			
32	-	15.0	16.0	4.0	-	4.0	15.0	-	-	-	15 / 13.5	7.0	15.0	7.0	-
		LK 4.0		8.0		8.0						10.0		11.5	
		LK 6.3		16.0		16.0						15.0		13.0	
		LK 10		LK 6.3		LK 6.3						LK 6.3			
				LK 10		LK 10						LK 10			
40	-	24.0	22.0	6.3	25.0	6.3	25.0	20.0	-	25.0	25 / 22	10.0	25.0	11.0	-
		LK 8		12.5	LK 20	12.5		LK 20				14.0		22.0	
		LK 10		25.0		25.0						25.0		25.0	
		LK 16		LK 10		LK 10						LK 10			
				LK 16		LK 16						LK 16			
50	-	35.0	-	10.0	36.0	10.0	42.0	36.0	-	36.0	42 / 36	15.0	42.0	18.0	36.0
		LK 16		20.0	LK 32	20.0		LK 36				23.0		32.0	
		LK 25		36.0		36.0						42.0		36.0	
				LK 16		LK 16						LK 16			
				LK 25		LK 25						LK 25			
65	-	70.0	-	16.0	63.0	16.0	63.0	50.0	63.0	63.0	63 / 55	23.0	63.0	24.0	-
		LK 16		32.0	LK 50	32.0		LK 50	LK 25			38.0		45.0	
		LK 25		63.0		63.0			LK 40			63.0		55.0	
		LK 32		LK 25		LK 25			LK 50			LK 25		62.0	
		LK 40		LK 40		LK 40						LK 40		63.0	
80	-	105.0	-	25.0	105.0	25.0	100.0	72.0	105.0	105 / 75	100 / 90	-	105.0	30.0	105.0
		LK 40		50.0	LK 80	50.0		LK 63	LK 40					52.0	
		LK 50		105.0		105.0			LK 63					71.0	
		LK 63		LK 40		LK 40			LK 80					80.0	
				LK 63		LK 63								91.0	
100	-	135.0	-	40.0	130.0	40.0	130.0	90.0	130.0	130 / 105	130 / 115	-	130.0	38.0	142.0
		LK 40		80.0	LK 100	80.0		LK 90	LK 63					69.0	
		LK 80		130.0		130.0			LK 80					86.0	
		LK 100		LK 63		LK 63			LK 100					100.0	
				LK 80		LK 80								112.0	
125	-	200.0	-	63.0	200.0	63.0	200.0	100.0	200.0	200 / 150	200 / 180	-	200.0	51.0	-
		LK 100		130.0	LK 130	130.0		LK 100	LK 100					80.0	
		LK 130		200.0		200.0			LK 130					100.0	
		LK 160		LK 100		LK 100								135.0	
				LK 130		LK 130								138.0	
150	-	-	-	360.0	360.0	360.0	360.0	200.0	-	360.0	360 / 320	-	-	110.0	-
				LK 130	LK 250	LK 250		LK 200						196.0	
				LK 200										304.0	
				LK 250											
200	-	-	-	580.0	580.0	580.0	-	-	-	580.0	-	-	-	-	-
				LK 320	LK 320	LK 320									
250	-	-	-	960.0	960.0	960.0	-	-	-	960.0	-	-	-	-	-
				LK 580	LK 580	LK 580									
300	-	-	-	1340.0	1340.0	1340.0	-	-	-	1340.0	-	-	-	-	-
				LK 960	LK 960	LK 960									

LK = cage plug

Note: Kvs values given in this form: XX/YY, denote Kvs values for the straight way (XX) and the angle way (YY)

Baelz-Katalog_11_EN_MJ_0221

page 70

baelz 206r



Pressure measuring and control element

- Bellows seal: stainless steel 1.4571
- Shaft lengths: 100, 200, 300 mm
- **Max. temperature / pressure:** 200 °C / 18 bar; 240 °C / 13 bar
- Connection: G 1/2
- Set pressure ranges: from 0.05...0.45 to 3.4...18

page 71

baelz 265st



Solenoid valve pilot

- Function: normally closed
- Seat diameter: 2.5...10mm
- Power supply: 24/230 VAC
- Weight, approx.: 1.3 / 3.5 kg
- Ambient temperature: 0 ... +80 °C
- Working fluid temperature : max 300°C
- Humidity: 0 ... 75%
- IP rating: IP65
- Body and spindle - stainl. steel 1.4301
spindle - stainless steel 1.4104
- Flange - galvanized steel 1.0037
- Connection: G 1/2

page 72

baelz 266st



Solenoid valve pilot

- Function: normally closed
- Seat diameter: 2.5...10mm
- Power supply: 24/230 VAC
- Weight, approx.: 1.6 / 3.5 kg
- Ambient temperature: 0 ... +80 °C
- Working fluid temperature: max 130°C
- Humidity: 0 ... 75%
- IP rating: IP65
- Body and spindle - stainl. steel 1.4301
spindle - stainless steel 1.4104
- Flange - galvanized steel 1.0037
- Connection: G 1/2

page 73

**baelz 268
baelz 268-Ex**



3-way direct acting solenoid valve

- Body: brass
- Seal: FPM
- Connection: G 1/4, internal thread
- Fluids: neutral gasses and liquids
- IP rating: IP 65
- Power supply: 230, 110 or 24 V
- Function: normally closed (NC)

page 74

baelz 279 / 280



Valve control units

- Simple 3-point step controller
- For use with pneumatic actuators
- Provides feedback to building management system
- Standard version includes power supply options
- Manometers optional
- Explosion protected models also available

page 75

baelz 6250



Perforated plate

- Reduces noise levels in steam pipelines
- Protects the valve from wear
- Available in steel or stainless steel
- Options for various forms of flange
- Suited for use with liquids, gases, water, steam, thermal oil



baelz 206r

DESCRIPTION

The pressure measuring and control element baelz 206r is generally used with baelz 192 as a pressure reducing valve. The set point can be selected by adjusting the tension in the springs using a handwheel.

TECHNICAL SPECIFICATIONS

Metal bellows seal: stainless steel 1.4571

Max. temperature /pressure:

Shaft length 100mm: 110 °C / 18 bar

200 mm: 200 °C / 18 bar

300 mm: 240 °C / 13 bar

Connection: G 1/2

Baelz-Type	Shaft length (mm)	Max. fluid temp. (°C)	Set pressure range (bar)	Weight, approx. (kg)
206r-10-0,45	100	110	0,05...0,45	3,1
206r-20-0,45	200	200	0,05...0,45	3,2
206r-30-0,45	300	240	0,05...0,45	3,4
206r-10-0,65	100	110	0,08...0,65	3,1
206r-20-0,65	200	200	0,08...0,65	3,2
206r-30-0,65	300	240	0,08...0,65	3,4
206r-10-1	100	110	0,14...1	3,1
206r-20-1	200	200	0,14...1	3,2
206r-30-1	300	240	0,14...1	3,4
206r-10-2,5	100	110	0,3...2,5	3,1
206r-20-2,5	200	200	0,3...2,5	3,2
206r-30-2,5	300	240	0,3...2,5	3,4
206r-10-3,4	100	110	0,5...3,4	3,1
206r-20-3,4	200	200	0,5...3,4	3,2
206r-30-3,4	300	240	0,5...3,4	3,4
206r-10-6,4	100	110	0,9...6,4	3,1
206r-20-6,4	200	200	0,9...6,4	3,2
206r-30-6,4	300	240	0,9...6,4	3,4
206r-10-8,8	100	110	2...8,8	3,1
206r-20-8,8	200	200	2...8,8	3,2
206r-30-8,8	300	240	2...8,8	3,4
206r-10-18	100	110	3,4...18	3,1
206r-20-18	200	200	3,4...18	3,2
206r-30-18	300	240	3,4...18	3,4

Note: For spare parts, see page 297 of this catalogue or get in touch with Baelz.



baelz 265st

DESCRIPTION

Normally closed (NC) solenoid valve pilot to control the reducing valve baelz 192 and the microflow control valve baelz 185

TECHNICAL SPECIFICATIONS

Ambient conditions:
 Temperature: 0 ... +80 °C
 Relative humidity: 0 ... 75%

Spindle tube - stainless steel 1.4301, 230 mm
 Spindle - stainless steel 1.4104
 Connecting flange - galvanized steel 1.0037

Connection: G 1/2

Type	Max. fluid temperature (°C)	Ø seat (mm)	Max. ΔP (bar)	Power supply	IP rating	Weight, approx. (kg)
265st-SK3	300	2,5	40	230 V, 24 V 50/60 Hz	IP 65	1,6
		3	40			
		4	22			
		5	14			
265st-K 16	300	6	28	230 V 50/60 Hz	IP 65	3,5
		8	19			
		10	12			

Dimensions baelz 265st (mm)

baelz 265st-SK3

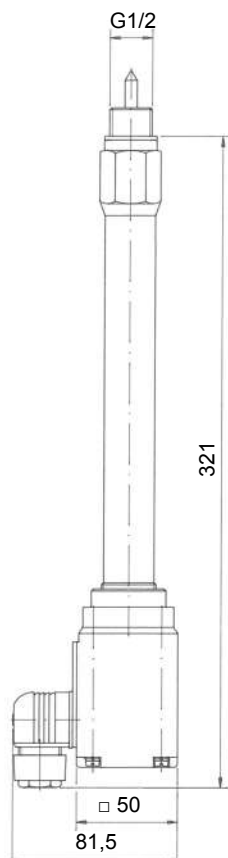

baelz 265st-K 16

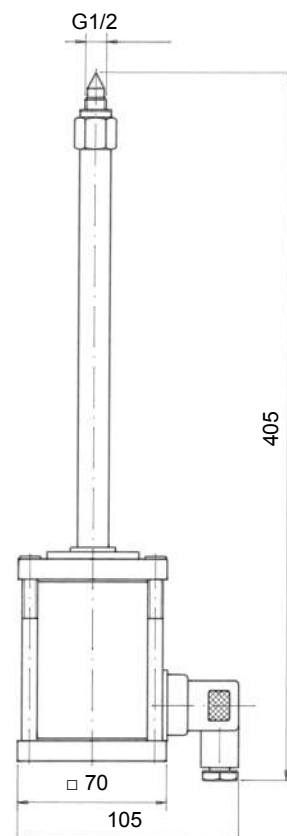



baelz 266st

DESCRIPTION

Normally closed solenoid valve pilot (NC) to control the reducing valve baelz 192 and the microflow control valve baelz 185

TECHNICAL SPECIFICATIONS

Ambient conditions:
 Temperature: 0 ... +80 °C
 Relative humidity: 0 ... 75%

Body (266st-VA) - stainless steel 1.4571
 Spindle - stainless steel 1.4104
 Connecting flange - galvanized steel 1.0037

Without spindle tube. Connection: G 1/2

Type	Max. fluid temperature (°C)	Ø seat (mm)	Max. ΔP (bar)	Power supply	IP rating	Weight approx. (kg)
266st/266st-VA	+130	2,5	40	230 V, 110 V, 24 V 50/60 Hz	IP 65	0,8
		3	40			
		4	22			
		5	14			
266st-K 16	+110	6	28	230 V 50/60 Hz	IP 65	0,8
		8	19			
		10	12			

Dimensions baelz 266st (mm)

baelz 266st

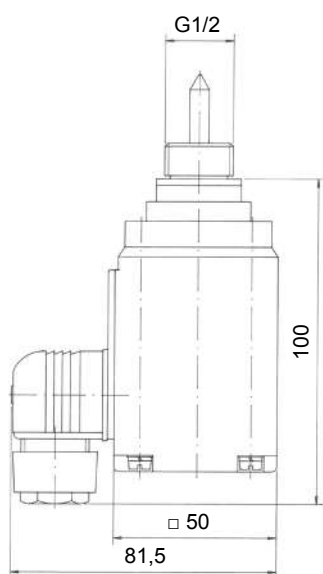

baelz 266st-K 16

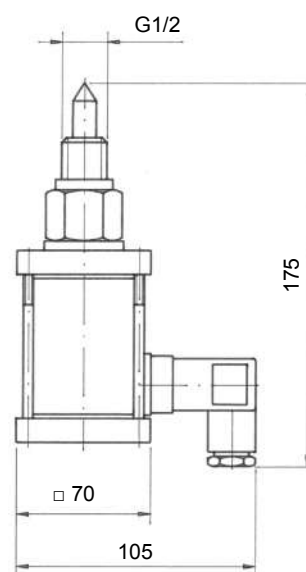



baelz 268

DESCRIPTION

Solenoid valve to control the air supply to pneumatic actuators

268/1 = 2-way solenoid valve; 268/2 = 3-way solenoid valve

TECHNICAL SPECIFICATIONS

Body:	brass
Seal:	FPM
Connection:	G 1/4, internal thread
Seat-Ø:	baelz 268/2: 2 mm, Kvs 0.11 baelz 268/1: 2 mm, Kvs 0.12
Ambient temperature:	-10...+55°C
Temperature range:	-10...+100°C
Fluids:	neutral gases and liquids
Pressure range:	baelz 268/2: 0... 6 bar for AC, 0...10 bar for DC baelz 268/1: 0... 16 bar for AC, 0...12 bar for DC in connection with baelz 373-P21/P22...P31/P32..., P41... Pmax. 6 bar
Electrical connection:	includes plug connection DIN EN 175301-803 Form A with LED and varistor
IP rating:	IP 65 with plug connection
Power supply:	230, 110 or 24 V, 50/60 Hz, 24 V DC (please specify when ordering)
Function:	normally closed (NC)
Fitting position:	any, but preferably with magnet upright
Weight, approx.:	baelz 268/2: 0.7 kg baelz 268/1: 0.5 kg

Accessories

ZB268-LED-240 ZB268-LED-120 ZB268-LED-24	Plug connection as a spare or to retrofit DIN EN 175301-803 Form A with LED and varistor for solenoid valves baelz 268..., 270/2, 271, 273-256, 276-255, 276-290, 276-407.	
	Power indicator	LED red
	electrical connection	screw terminals max. 1,5 mm ²
	Power supply	240, 120, or 24 V AC/DC
	IP rating	IP 65
	Weight	approx. 0.1 kg

Not suitable for explosion protected version.

Supplementary charge for fitting baelz 268 / 268-Ex to an actuator baelz 373-P...: MP268-M

baelz 268-Ex

DESCRIPTION

Explosion protected solenoid valve to control air supply to pneumatic actuators

268/1-Ex = 2-way solenoid valve; 268/2-Ex = 3-way solenoid valve

TECHNICAL SPECIFICATIONS

Body:	brass
Seal:	FPM
Connection:	G 1/4, internal thread
Seat-Ø:	baelz 268/2-Ex: 2 mm, Kvs 0.11 baelz 268/1-Ex: 2.5 mm, Kvs 0.16
Ambient temperature:	T4 = -10...+55 °C
Fluid temperature:	T4 = -10...+100°C
Fluid:	neutral gases and liquids
Pressure range:	0...10 bar with baelz 373-P21/P22...P31/P32..., in connection with P41... Pmax. 6 bar
IP rating:	IP 65
Power supply:	230, 110 or 24 V UC, 9 W
Function:	normally closed (NC)
Fitting position:	any, but preferably with magnet upright
Weight, approx.:	baelz 268/2-Ex: 0.7 kg baelz 268/1-Ex: 0.5 kg
Explosion protection:	II 2G Ex eb mb IIC T4 Gb II 2D Ex mb tb IIIC T130°C Db ATEX 1046X



Note: Explosion protected solenoid valves baelz 268/1-Ex and 268/2-Ex should be protected by the following medium time delay fuses at the site of installation: 230 V UC, 9W: 100 mA; 110 V UC, 9 W: 215 mA; 24 V UC, 9 W: 1000 mA.

baelz 279 / 280



baelz 280

DESCRIPTION

Simple 3-point step controller for pneumatic actuators combined with control valves. Uncomplicated controllers offering full communication capabilities and feedback to the building management system.

TECHNICAL SPECIFICATIONS

Components of baelz 279 / baelz 280:

2 2-way solenoid valves, baelz 268/1 or 268/1 Ex (explosion protected version). For baelz 280 additionally **1 3-way solenoid valve** baelz 268/2 or 268/-Ex for safety cut-off in case of power supply failure.

Casing: brass
 Seals: FPM
 Connection: G 1/4 internal thread
 Ambient temperature: -10...+55 °C
 Pressure range: 0...6 bar
 Power supply: 230 V, 50/60 Hz; 110 V, 50/60 Hz; 24 VAC/DC or VUC (Ex-version)

2 needle valves, baelz 520

Casing: brass
 Connection: G 1/4 internal thread

T-connector G1/4 external thread, for membrane connection

		Options	
Option	Description	Type number suffix baelz 279- .../ 280-...	example of type no.
-	Standard version with power supply options	230 / 110 / 24VAC / 24VDC	280-24VAC
70802	with 2 Bourdon tube manometers: casing-Ø 63 mm; G1/4A connector on bottom; range 0...4 or 0...6 bar	70802-63-u-4 (range 0...4 bar) 70802-63-u-6 (range 0...6 bar)	279-110-70802-63-u-6
Ex	explosion protected version II 2 G EEx m II T4 PTB00 ATEX 2129X; electrical connection: terminal box (without manometer)	Ex-230VUC Ex-110VUC Ex-24VUC	279-Ex-230VUC
M*	including fitting to diaphragm actuator*	M	280-230-70802-63-u-4-M

* also available separately as MP279-6001 / MP280-6001

Weight (kg), approx.	
279 / 279-Ex	1,4
279-70802	1,8
280 / 280-Ex	2,1
280-70802	2,5

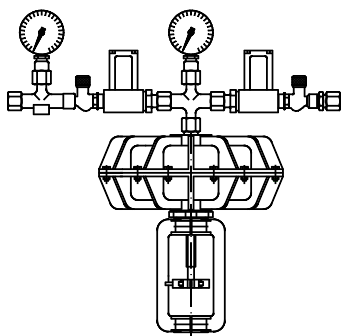

baelz 279 - shown with P21 actuator

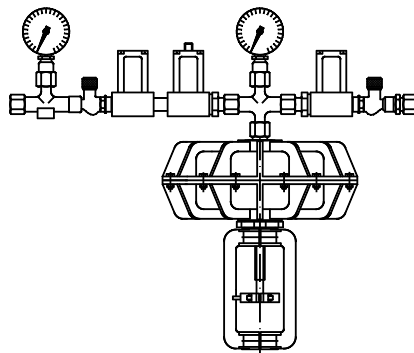

baelz 280 - shown with P21 actuator

Note: Explosion protected solenoid valves baelz 268/1-Ex and 268/2-Ex should be protected by the following medium time delay fuses at the site of installation:

Solenoid valve 230 V UC: 9 W, 110 mA
110 V UC: 9 W, 215 mA
24 V UC: 9 W, 1000mA

baelz 6250

DESCRIPTION

The baelz 6250 perforated plate protects the valve against damage caused by an excessive pressure drop and has a noise-damping effect. The perforated plate is connected downstream from the valve and absorbs most of the pressure drop. Thus, the cheap perforated plate is „sacrificed“ to prevent damage to the expensive valve.

TECHNICAL SPECIFICATIONS

Material: Steel 1.0460 / Stainless steel 1.4571
 Nominal pressure: PN 16 / PN 40
 Temperature: Steel: max. 400 °C
 Stainless steel: max. 500 °C



T max. / P max. baelz 6250			
Hot forged steel - 1.0460		Stainless steel - 1.4751	
PN 16	PN 40	PN 16	PN 40
400 °C / 9.5 bar	400 °C / 23.8 bar	500 °C / 12 bar	500 °C / 30 bar
300 °C / 11 bar	300 °C / 27.6 bar	400 °C / 12.4 bar	400 °C / 31.2 bar
50 °C / 16 bar	50 °C / 40 bar	50 °C / 16 bar	50 °C / 40 bar

Weight baelz 6250, aprox. (kg)		
DN (mm)	PN 16	PN 40
15	0.8	0.9
20	1	1.3
25	1.3	1.4
32	1.8	2.1
40	2.1	2.4
50	2.9	3.2
65	3.7	4.3
80	4.8	5.9
100	5.7	7.6
125	8.5	10.8
150	10.6	14.5
200	16.1	27.2
250	25	44
300	35.1	63.5

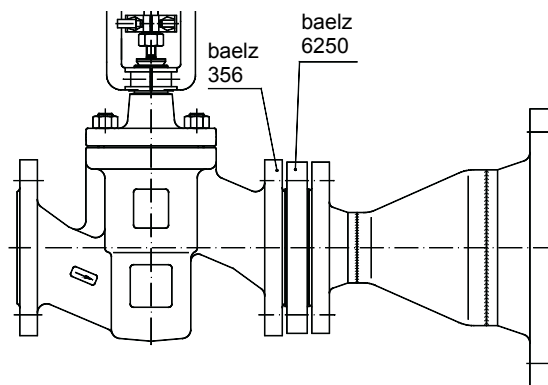

Example of mounting a baelz 6250 noise-damping perforated plate in the pipeline

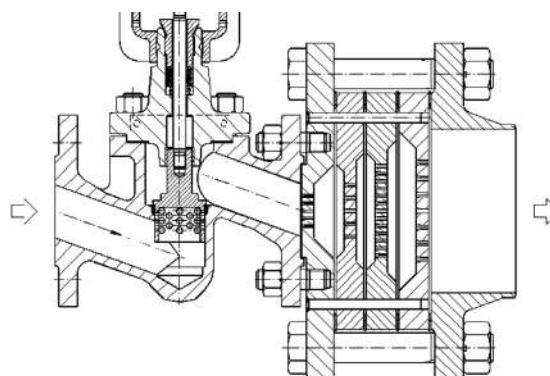

Example of mounting several baelz 6250 noise-damping perforated plates in the pipeline

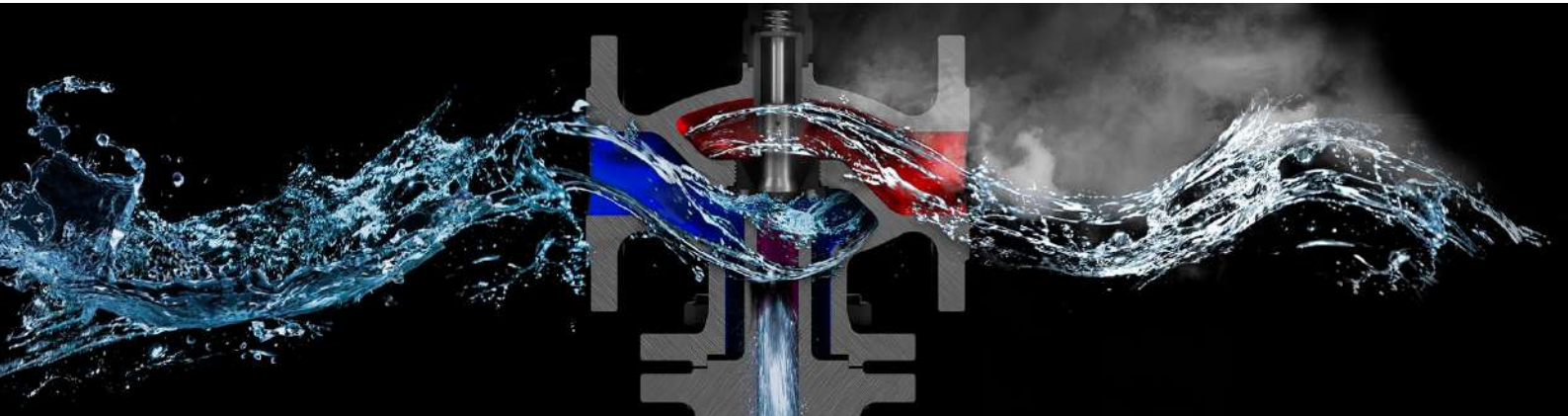

Baelz-hydrodynamic®

The controlled water ejector combines the functions of four single components: It generates circulation in the area of the consumer, it adjusts the circulation volume according to the actual heat requirement, it regulates the temperature and compensates for fluctuations in differential pressure.

Baelz-vapordynamic®

The functional principle of the regulated ejector is also applicable for steam. Here, smooth-running equipment is of the essence. Factors such as production reliability, energy costs and maintenance expenditure are crucial for success in all industries.

**Note: For systems with ejectors, see Chapter 6.2
"Ejector technology - the basics" starting on page 195 of this catalogue.**

2.1 Ejectors - Product identification

2 examples of type numbers: baelz 474-MMJV-G3/4-PN25-D2mm / baelz 480-6-DN 50-PN 16/25-Düse 16 mm

baelz -
XXX-X -
 X -
 GXX -
 DNXX -
 PNXX -
 Düse XXmm

Series						
See Baelz Pricelist for current serial numbers	471-X					
	472-X					
	474					
	475-X					
	480-6					
	585-X					
	590-X					
591-X						
Options						
see Baelz Pricelist		MMJV	G3/4			
Nominal diameter						
				DN 50		
Nominal pressure						
					PN16/25	
					PN25	
Nozzle diameter						
						Düse 16 mm
						D2mm

Düse = nozzle

Notes:

All available type designations and order numbers can be found in the Baelz price list .
 There are various options for ejectors available for a supplementary cost (order and type numbers start with "MP") eg.:
 Weld-on and threaded sockets, cooling tube, flange machining, silicone free

page 79

baelz 471



**Controlled water ejector
Jetomat**

- 1/2"– 1 1/2"
- PN16/25
- External thread
- Housing CC491K - CuSn5Zn5Pb5-C
- max. 150°C
- PTFE seal
- Mixes water with water
- For heating systems



page 81

baelz 472



**Controlled water ejector
Jetomat**

- 2"
- PN16
- External thread
- Housing CC499K - CuSn5Zn5Pb2
- max. 130°C
- PTFE seal
- Mixes water with water
- For heating systems



page 82

baelz 474



**Four-way radiator ejector
Jetomat**

- 2 x 3/4". 2 x M22x1.5 mm
- PN25
- External thread
- Housing CW508L - CuZn37
- max. 140°C
- 2 exchangeable O-rings
- Mixes water with water
- For heating systems



page 84

baelz 475



**Controlled water ejector
Jetomat**

- 3/4"
- PN16/25
- External thread
- Housing CC491K - CuSn5Zn5Pb5-C
- max. 150°C
- EPDM seal
- Mixes water with water
- For heating systems



page 85

baelz 480



**Controlled water ejector
Jetomat**

- DN15-250
- PN16/25/40
- Flanged connection
- Housing 5.3103 - EN-GJS-400-18-LT
- max. 240°C
- Cooling tube optional
- Mixes liquids
- Industrial applications



page 87

baelz 585



**Controlled steam / water
mixing ejector Jetomat**

- DN15-125
- PN16/25
- Flanged connection
- Housing 5.3103 - EN-GJS-400-18-LT
- max. 240°C
- Mixes water with steam
- Water heating by direct steam injection
- Industrial applications



page 89

baelz 590



**Controlled steam ejector
Jetomat**

- DN15-250
- PN16/25/40
- Flanged connection
- Housing 5.3103 - EN-GJS-400-18-LT
- max. 350°C
- Cooling tube optional
- Mixes steam
- Industrial applications



page 91

baelz 591



**Steam cooling and
reducing Jetomat**

- DN32-300
- PN16/25/40 (max. PN 160 on request)
- Flanged connection
- Housing 5.3103 / 1.0619
- max. 350°C
- Cooling tube optional
- Cools hot steam with water
- Reducing cooling valve
- Industrial applications





baelz 471

DESCRIPTION

The baelz 471 Jetomat is a controlled water/water ejector with red brass housing and threaded connections for heating systems.

Housing / diffusor and nozzle made of CuSn5Zn5Pb5-C red brass

TECHNICAL SPECIFICATIONS

The plug type and the control characteristic are designed and manufactured to order.

Stroke:
 12 mm for nozzle diameters < 9 mm
 22 mm for nozzle diameters ≥ 9 mm

Spindle diameter: 10 mm

Working fluids: water

Designation	Nominal pressure	Housing material	Nominal diameter	Connection	Leakage class (EN 1349)
baelz 471	PN 16 / 25	Red brass CuSn5Zn5Pb5-C	1/2" - 1 1/2"	External thread with union nut made of brass and weld-on sockets made of steel	metal-to-metal seal: 0.004% Kvs (better than class IV)

T max. (°C) / P max. (bar)	
Housing material	Red brass CuSn5Zn5Pb5-C
Nominal pressure	PN 16 / 25
baelz 471	
baelz 471-GT	150 / 25
baelz 471-ASE	

Additional options	Designation
G½ - G1 available with threaded sockets in brass	MP471-GT-G...
Weld-on sockets in stainless steel	MP471-ASE-G...

Available nozzle diameters (mm)					
DN	1/2"	3/4"	1"	1 1/4"	1 1/2"
Ø	3	3	6	6	6
	4	4	9	9	9
	5	5	12	12	12
	6	6			16
		9			

Dimensions of the baelz 373 actuators (mm)					
Designation	L	x	Ød	l	ØD
E07	320	145	129		
P11				244	160
P21				268	242

Electric actuators: baelz 373-E
 Pneumatic actuators: baelz 373-P

baelz 471 dimensions and weight								
DN		h1	h3	BL1	BL2	G	Weight, approx.	
		mm						kg
1/2"	15	126	162	92	164	3/4	2	
3/4"	20	153	189	95	167	1	2.6	
1"	25	210	251	105	187	1 1/4	3.1	
1 1/4"	32	245	286	105	187	1 1/2	4.1	
1 1/2"	40	311	357	114	206	2	5.7	

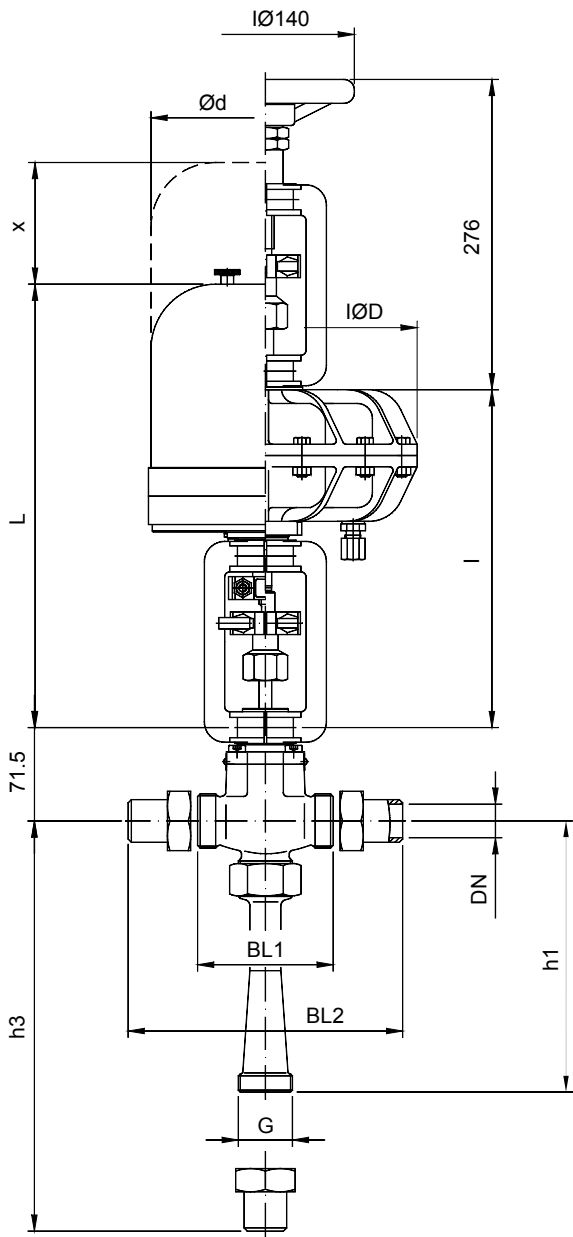

baelz 471 DN1/2-1 1/2

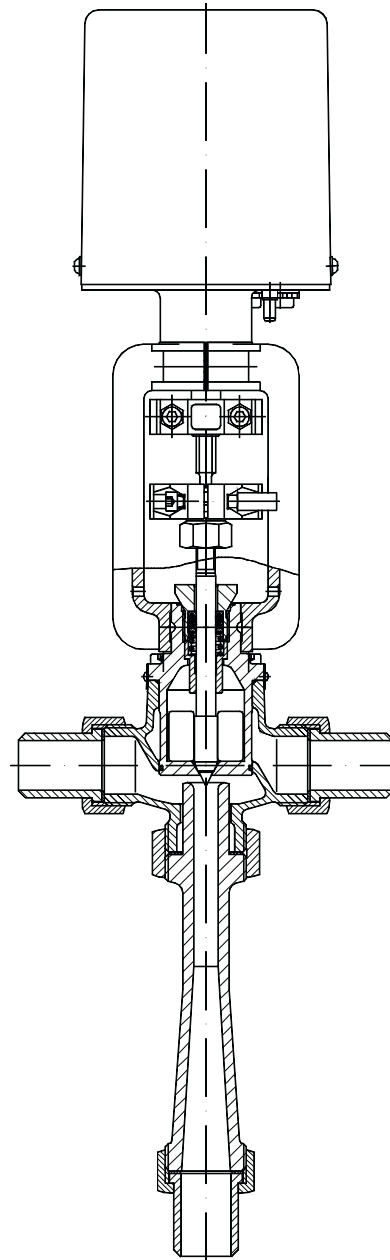

baelz 471



baelz 472

DESCRIPTION

The baelz 472 Jetomat is a small controlled water/water ejector with red brass housing and threaded connections for heating systems.

Housing made of red brass CuSn5Zn5Pb2
 Diffuser made of red brass CuZn40Pb2
 Nozzle made of stainless steel

TECHNICAL SPECIFICATIONS

The plug type and the control characteristic are designed and manufactured to order.

Stroke - 22 mm
 Weight without actuator (approx.) – 7.8 kg
 Spindle diameter - 10 mm

Working fluids: water

baelz 472	
Housing material	red brass CuSn5Zn5Pb2
Nominal pressure	PN 16
T max. (°C) / P max. (bar)	130 / 16
Min. ambient temperature (°C)	-10
Nominal diameter	2"
Connection	External thread with union nut made of brass and weld-on sockets made of steel
Available nozzle Ø (mm)	16, 20, 23, 25, 30
Leakage class (EN 1349)	metal-to-metal seal: 0.004% Kvs (better than class IV)

Additional options	Designation
V-shaped seal heating (for fluids at temperatures of - 10... - 40 °C) Pmax. 20 W; 12-24 V / 110-230 V AC/DC	baelz 85950...

Dimensions of the baelz 373 actuators (mm)					
Designation	L	x	Ød	l	ØD
E07	320	145	129		
P11				244	160
P21				268	242

Electric actuators: baelz 373-E
 Pneumatic actuators: baelz 373-P

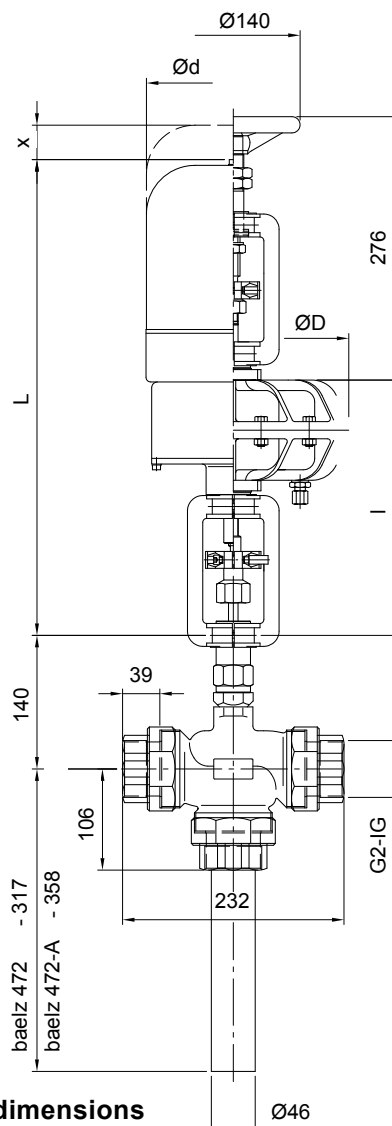

baelz 472 dimensions



baelz 474

DESCRIPTION

The baelz 474 is a four-way radiator water/water ejector with red brass housing and threaded connection for heating systems.

Housing made of cast brass CuZn37
Internal parts made of stainless steel

TECHNICAL SPECIFICATIONS

Stroke - 3 mm
Weight, approx. : 0.65 to 0.9 kg depending on the equipment

With different nozzle inserts according to the design
Several control / actuator options.
Also applicable as minimum quantity injection valve.
Working fluids: water

baelz 474-RT...	
Housing material	cast brass CuZn37
Nominal pressure	PN 25
T max. (°C) / P max. (bar)	140 / 25
Min. ambient temperature (°C)	1
nozzle diameter (mm)	2 or 3
Connection	External thread
Leakage class (EN 1349)	metal-to-metal seal: 0.004% Kvs (better than class IV)

baelz 474 with thermostat		
	474-RT-T	474-RT-70521-10-AZ
Control	with thermostatic head	Control top with remote adjustment Thermostat with liquid sensor
Capillary tube length (m)	-	2
Setpoint range (°C)*	6 to 28	
Frost protection	adjustable at approx. 6°C	
Connecting thread	M 30 x 1.5 mm	
Weight, approx. (kg)	0.65	0.75

* Limitation and locking of the setpoint range possible

baelz 474 with electromotive actuator with manual operation/override and position indicator					
	474-RT-373-ESI-31...	474-RT-373-ESI-31.1/L15-230	474-RT-373-ESI-61...	474-RT-373-ESI-81...	474-RT-373-ESI-81.1/L15-24
Housing	Plastic, maintenance-free				
Thrust (N)	100				
Actuating speed	194 s / 3 mm stroke	194 s / 3 mm stroke	45 s / 3 mm stroke	192 s / 3 mm stroke	192s / 3 mm stroke
IP rating	IP 40				
Activation/control	3-point	3-point	DC 0...10 V	3-point	3-point
Fluid temperature (°C)	max. 1...110	max. 1...110	max. 1...100	max. 1...110	max. 1...110
Environmental conditions	1...50°C; 5...85 % RH				
Connecting thread	M 30 x 1.5				
elec. connection	3-core cable*				
Power supply	230 V AC. ± 15 %. 50/60 Hz				
with auxiliary switch as a changeover switch	No	Yes	No	No	Yes,
Weight, approx. (kg)	0.8	0.9	0.8	0.8	0.9

baelz 474 as a minimum quantity injection valve	
474-MMJV	
Design	as overflow valve with manual operation
Connections	1 x M 22 x 1.5 mm: input 01 1 x G 3/4: output 04, with 1 adapter/transition section G 3/4 to M 22 x 1.5 mm
Weight, approx. (kg)	0.85

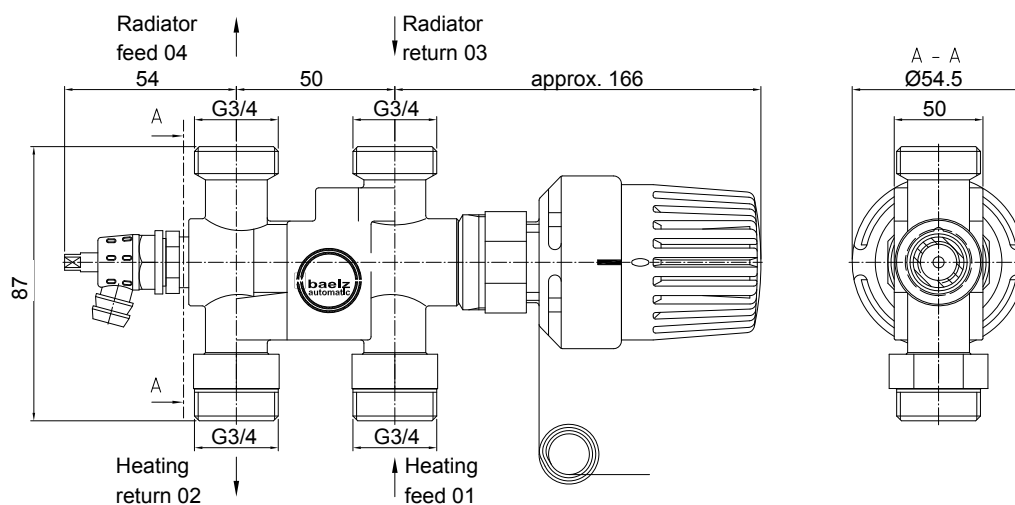

baelz 474-RT dimensions

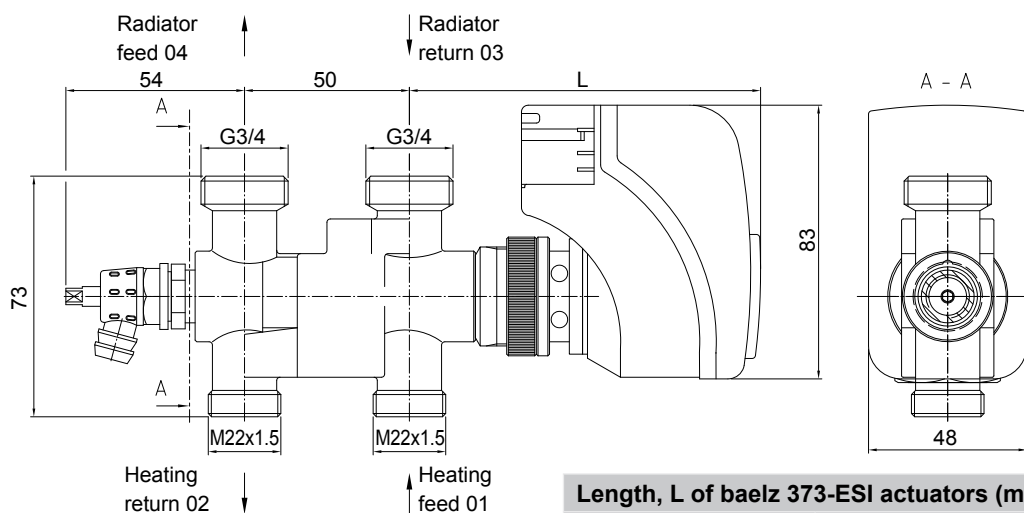

baelz 474-RT-373-ESI... dimensions

Length, L of baelz 373-ESI actuators (mm)	
Designation	L
ESI-31	107
ESI-31.1	124
ESI-61	107
ESI-81	107
ESI-81.1	124

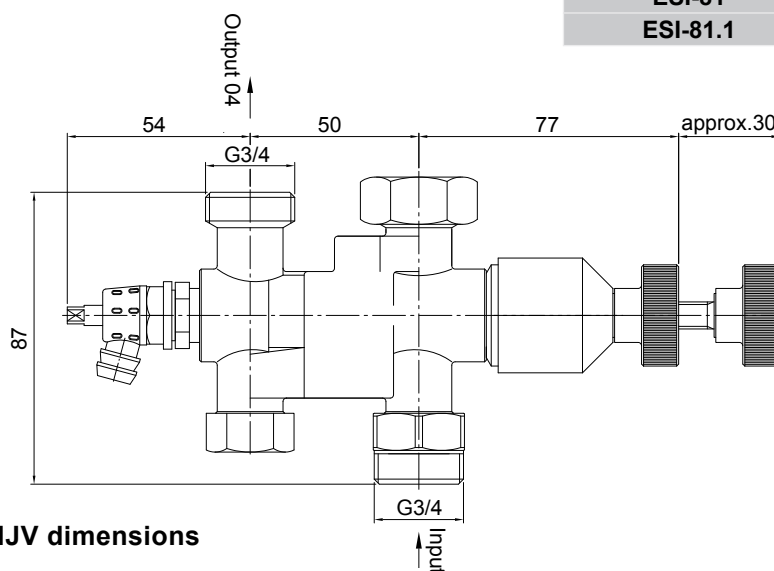

baelz 474-MMJV dimensions



baelz 475

DESCRIPTION

The baelz 475 Jetomat is an economical water/water ejector with red brass housing and threaded connection for heating systems.

Housing: red brass CuSn5Zn5Pb5-C
 Diffuser: brass
 Plug stem and nozzle: stainless steel

TECHNICAL SPECIFICATIONS

The plug type and the control characteristic are designed and manufactured to order.

Stroke: 6 mm
 Weight without actuator: approx. 1.3 kg
 Connection thread for actuator: M 30 x 1.5 mm

Working fluids: water

Designation	Nominal pressure	Housing material	Nominal diameter	Connection	Leakage class (EN 1349)
baelz 475	PN 16 / 25	Red brass CuSn5Zn5Pb5-C	3/4"	External thread with union nut made of brass and weld-on sockets made of steel	metal-to-metal seal 0.004% Kvs (better than class IV)

T max. (°C) / P max. (bar)		
Housing material	Red brass CuSn5Zn5Pb5-C	
Nominal pressure	PN 16 / 25	
baelz 475-2-G 3/4-PN 16/25...	controlled water ejector	110 / 16
		110 / 25
baelz 475-2-G 3/4-PN 16/25... + MP475-K	controlled water ejector with cooling insert	150 / 16
		150 / 25
baelz 475-SM-E01-UC8-G3/4-PN16...	motorized controlled water ejector	90 / 10

Kvs and nozzle diameter (mm)					
Kvs	0.8	1.6	2.6	3.5	6.25
Ø	2.5	2.5	2.5	2.5	2.5
		3.5	3.5	3.5	3.5
			5	5	5
				6.5	6.5
					8

Length, L of baelz 373-ESI actuators (mm)	
Designation	L
ESI-31	107
ESI-31.1	124
ESI-61	107
ESI-81	107
ESI-81.1	124

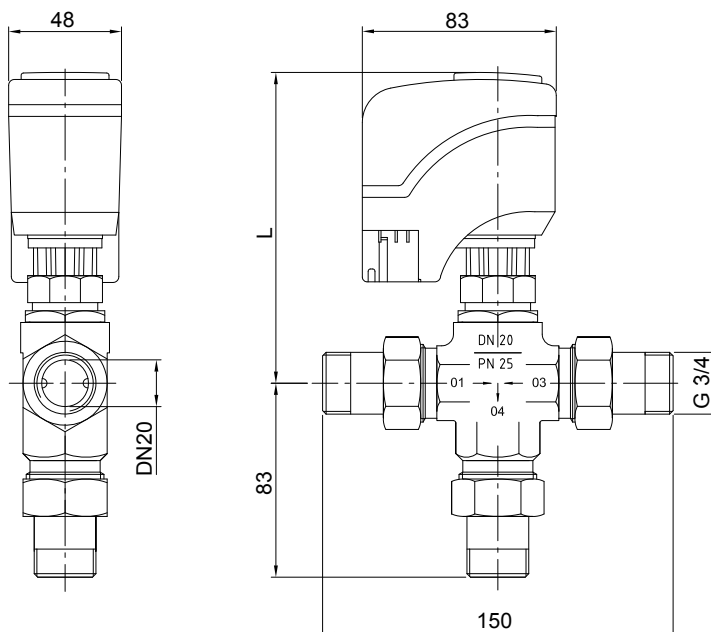

baelz 475 with electric actuator 373-ESI dimensions

Optional extras:
 MP475-H - Manual regulator, brass
 MP475-K - Cooling insert



Leakage class (EN 1349)

metal-to-metal seal: 0.004% Kvs (better than class IV)

baelz 480

DESCRIPTION

The baelz 480 Jetomat is a controlled liquid/liquid ejector with flange connection for mixing and recirculation

Housing: GJS-400-18-LT - 5.3103 / GP240GH - 1.0619 (PN 40 & DN 250)

Diffuser: DN 15: X14CrMoS17

DN 25...125: GJS-400-18-LT

≥ DN 150 and all PN 40: steel, welded

Plug stem and nozzle: stainless steel

TECHNICAL SPECIFICATIONS

Connection type: Flange EN 1092-2; EN 1092-1 Shapes D / E / F on request

The plug type and the control characteristic are designed and manufactured to order.

Spindle seal: V-rings in PFTE, DN 15-125 with wiper set

Option: baelz 480-K - with cooling tube

Working fluids: liquids, water, thermal oil

	Stroke (mm)	Spindle Ø (mm)
DN 15 - DN 25. nozzle ≤ 6.5 mm	12	10
DN 15 - DN 25. nozzle > 8 mm	22	10
DN 32 - DN80	22	10
DN 100 - DN 125*	22 and 40*	16
DN 150	40 and 44	16 / 22
DN 200 - DN 250	66	22

*recommended actuators for DN 100 and DN 125:

Stroke 22, Actuator 373-P21-L...

Stroke 40, Actuator 373-P22-L...

Housing material	T max. (°C) / P max. (bar)				
	GJS-400-18-LT - 5.3103		GP240GH - 1.0619		GP240GH - 1.0619
Nominal pressure	PN16	PN25	PN16	PN25	PN40
baelz 480 DN15-DN125	240 / 14 ... 50 / 16	240 / 22 ... 50 / 25			
baelz 480 DN150-DN200	240 / 12,3 ... 50 / 16	240 / 19,3 ... 50 / 25			240 / 30,9 ... 50 / 40
baelz 480 DN250	-	-	240 / 12,3 ... 50 / 16	240 / 19,3 ... 50 / 25	
baelz 480-K DN15-DN200	350 / 11,2 ... 50 / 16	350 / 17,5 ... 50 / 25			
baelz 480-K DN250	-	-	240 / 10,2 ... 50 / 16	240 / 16 ... 50 / 25	350 / 25,7 ... 50 / 40

DN	Available nozzle diameters (mm)											
	15	25	32	40	50	65	80	100	125	150	200	250
Ø	2.5	6.5	8	10	12.5	16	20	25	32	40	65	80
	3.2	8	10	12.5	16	20	25	32	40	50	80	100
	4	10	12.5	16	20	25	32	40	50	65	100	120
	5				23	30	37	47	60		110	
	6.5											
8												

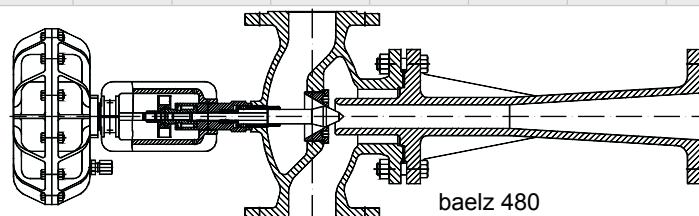

baelz 480

Approximate weights of the baelz 480 (kg)

DN	15	25	32	40	50	65	80	100	125	150	200	250
Spheroid ductile iron	6.3	9.1	14.9	19.3	25.3	40.4	50.6	68	104.3	145	300	450
Steel	7.4	10.2	16	20.4	27	42	52.6	70	106.3	148	310	460

baelz 480 dimensions (mm)

DN	BL	h1		h2	
		PN16/25	PN40	480	480-K
15	130	85	85	109	261
25	160	202	229	110	163
32	180	302	302	104	339
40	200	358	358	114	349
50	230	402	429	124	359
65	290	539	573	144	379
80	310	600	695	154	389
100	350	624 (912)	912	204	404
125	400	836 (1066)	1066	224	424
150	480	1260		244	
200	600	1651		268	
250	730	2070		317	

Dimensions of the baelz 373 actuators (mm)

Designation	L	x	Ød	l	ØD
E07	320	145	129		
E45	560	150	175		
P11				244	160
P21				268	242
P21-V6				304	242
P22				322	242

Electric: baelz 373-E; Pneumatic: baelz 373-P

The differential pressures specified here are limited by the nominal pressure of the housings, if this is lower.

Electric actuators. baelz 480, 590. Plug closes in direction of flow.

Actuator	Power (N)	Nozzle Ø (mm) / Maximum differential pressure ΔPmax (bar)																
		≤ 12.5	16	20	23	25	30	32	37	40	47	50	60	65	80	90	100	120
E07- OSX-	700	64.2	26.7	16.9	12.8	10.8	7.6	6.7	5.1	4.8	3.4	3	2.1					
E07-	2000	181	75	47	36	30	21	18	14	13	9.7	8.5	5.9					
E65- 11-	1100	86	36	22	17	14	10	9	6.8	6.4	4.6	4.1	2.8					
E65- 20-	2000	181	75	47	36	30	21	18	14	13	9.7	8.5	5.9					
E45-	4000			97	73	62	43	38	29	27	19	17	12	11				
E66-	15000									106	76	67	46	43	27	21	17	11
E88- 100-	10000									69	50	44	30	28	17	14	11	7.7

Pneumatic actuators. baelz 480, 590. Plug closes in direction of flow.

Actuator	Power (N)	req. feed pressure (bar)	Nozzle Ø (mm) / Maximum differential pressure ΔPmax (bar)															
			≤ 20	23	25	30	32	37	40	47	50	60	65	80	90	100	120	
P11- 1-	950	6.0	84	68	58	41	36	27										
P21- 3-	1020	3.0	141	106	90	63	56	42	40	29	25	17						
P21- 6-	2040	3.0	123	93	79	55	49	37	35	25	22	15						
P21- 6-	2040	6.0	294	223	189	133	117	89	83	60	53	36						
P22- 3-	1846	3.0							37	26	23	16	15					
P22- 6-	3692	6.0							73	52	46	32	30					
P31- 3-	2480	3.0							110	79	69	48	45					
P31- 6-	4960	3.0							93	67	59	41	38					
P31- 6-	4960	6.0							220	158	139	96	89					
P32- 6-	4402	3.0									61	42	39	25	19	15	11	
P32- 6-	4402	6.0									141	98	91	57	45	36	25	
P41- 6-	7530	6.0									281	195	180	114	89	71	49	

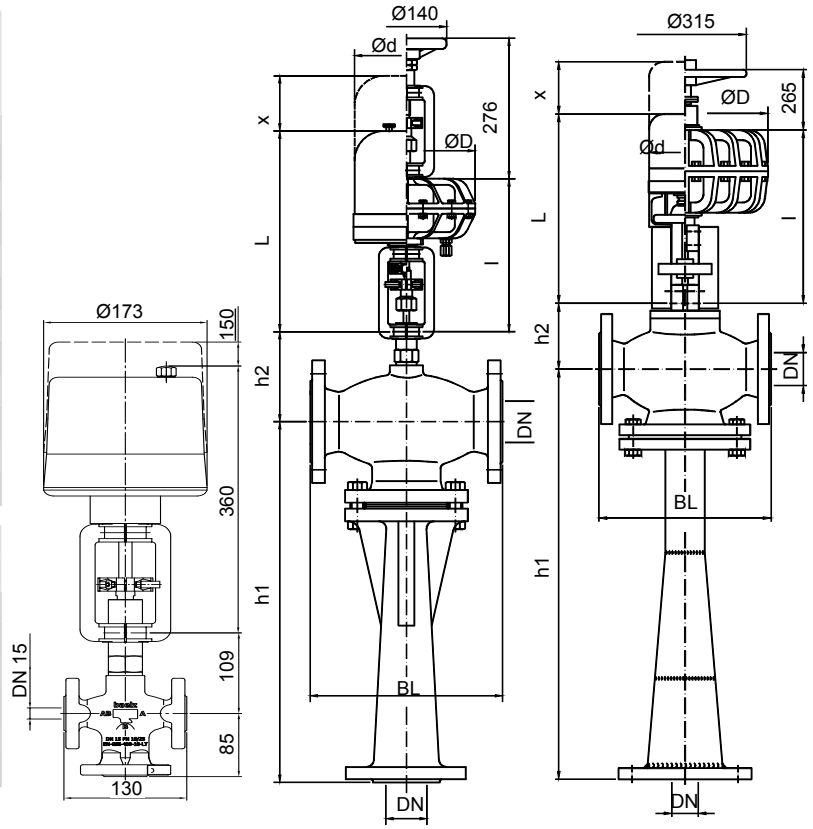

baelz 480 DN15

baelz 480 DN15-125

baelz 480 DN150-300



baelz 585

DESCRIPTION

The baelz 585 is a liquid/steam ejector with a flange connection for direct mixing of steam and water. (Water heating by direct steam injection).

Housing: GJS-400-18-LT - 5.3103
 Inner parts: hardened stainless steel

TECHNICAL SPECIFICATIONS

Connection type: Flange EN 1092-2; EN 1092-1 Shapes D / E / F on request

The plug type and the control characteristic are designed and manufactured to order.

Spindle seal: V-rings in PTFE
 Option: baelz 585-K - with cooling tube

Working fluids: water

Leakage class (EN 1349)

metal-to-metal seal: 0.004% Kvs (better than class IV)

Stroke (mm)

Spindle Ø (mm)

DN 15 - DN 25	22	10
DN32 - DN50		
DN50 - DN125		16

T max. (°C) / P max. (bar)

Housing material	Spheroid ductile iron GJS-400-18-LT - 5.3103	
Nominal pressure	PN16	PN25
baelz 585 DN15-DN125	240/14 ... 50/16	240/22 ... 50/25

The differential pressures specified here are limited by the nominal pressure of the housings, if this is lower.

Electric actuators baelz 585. Plug closes in direction of flow.

Actuator baelz 373-	Power (N)	Nozzle Ø (mm) / Maximum differential pressure ΔPmax (bar)																
		≤ 12.5	16	20	23	25	30	32	37	40	47	50	60	65	80	90	100	120
E07-	181	75	47	36	30	21	18	14	13	9.7	8.5	5.9						
E65- 11-	86	36	22	17	14	10	9	6.8	6.4	4.6	4.1	2.8						
E65- 20-	181	75	47	36	30	21	18	14	13	9.7	8.5	5.9						
E45-			97	73	62	43	38	29	27	19	17	12	11					
E88- 100-	10000									69	50	44	30	28	17	14	11	7.7

Pneumatic actuators baelz 585. Plug closes in direction of flow.

Actuator baelz 373-	Power (N)	required feed pressure (bar)	Nozzle Ø (mm) / Maximum differential pressure ΔPmax (bar)									
			≤ 20	23	25	30	32	37	40	47	50	60
P21- 3-	1020	3.0	141	106	90	63	56	42	40	29	25	17
P21- 6-	2040	3.0	123	93	79	55	49	37	35	25	22	15
P21- 6-	2040	6.0	294	223	189	133	117	89	83	60	53	36

Dimensions and weight of the baelz 585 (mm)

DN	BL	ØR	h1	h2		h3	Weight, approx. (kg)
				585	585-K		
15	130	15	85	109	261	142	6
25	160	26	85	110	262	142	7
32	180	35	100	104	339	157	10.5
40	200	41	105	114	349	162	12.5
50	230	52	115	124	359	172	17
65	290	68	125	144	379	182	25
80	310	80	130	154	389	187	29
100	350	105	150	169	404	207	40
125	400	128	200	189	424	257	60

Dimensions of the baelz 373 actuators (mm)

Designation	L	x	Ød	l	ØD
E07	320	145	129		
E45	560	150	175		
P11				244	160
P21				268	242
P21-V6				304	242
P22				322	242

Electric actuators: baelz 373-E

Pneumatic actuators: baelz 373-P

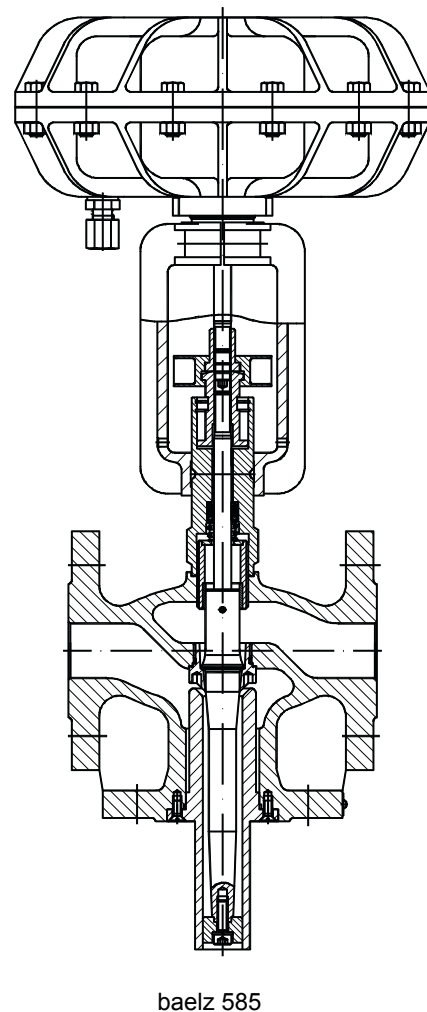
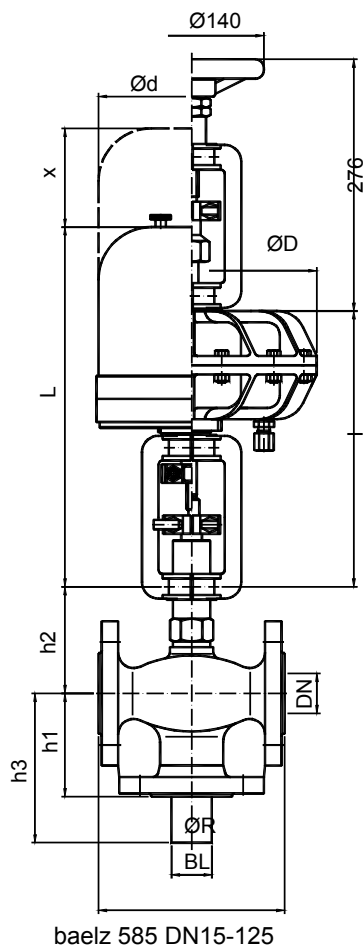



baelz 590

DESCRIPTION

The baelz 590 is a steam/steam ejector (thermocompressor) with flange connection for recirculation and compression of exhaust vapor.

Housing: GJS-400-18-LT - 5.3103 / GP240GH - 1.0619 (PN 40)

Diffuser: DN 15: X14CrMoS17

DN 25...125: GJS-400-18-LT

≥ DN 150 and all PN 40: steel, welded

Plug Spindle and nozzle: stainless steel

TECHNICAL SPECIFICATIONS

Flange: Special design according to EN 1092-1 possible

The plug type and the control characteristic are designed and manufactured to order.

Spindle seal: V-rings in PFTE, DN 15-125 with wiper set

Option: baelz 590-K - with cooling tube

Option: silicone-free version

Working fluids: steam

Leakage class (EN 1349)

metal-to-metal seal: 0.004% Kvs (better than class IV)

Spindle Ø (mm)

DN 15	10
DN 25 - DN 80	
DN 100 - DN 125*	16
DN 150	16 / 22
DN 200 - DN 250	22

Nozzle Ø (mm)

2,5 - 6,5	12
8 - 23	22
25-65	40
25-50	44
65-120	66

Stroke

*recommended actuators for DN 100 and DN 125:

Stroke 22, Actuator 373-P21-L...; Stroke 40, Actuator 373-P22-L...

T max. (°C) / P max. (bar)

Housing material	GJS-400-18-LT - 5.3103		GP240GH - 1.0619
	PN 16	PN 25	PN 40 / DN 250 for all nominal pressures
baelz 590 DN 15 - DN 125	240/14 ... 50/16	240/22 ... 50/25	240/30.9 ... 50/40
baelz 590 DN 150 - DN 200	240/12.3 ... 50/16	240/19.3 ... 50/25	
baelz 590-K DN 15 - DN 200	350/11.2 ... 50/16	350/17.5 ... 50/25	350/25.7 ... 50/40

Material diffusor

Designation	Nominal pressure	Material
590 DN 15	PN 16 / 25	X14CrMoS17 - 1.4104
590 DN 25...DN 125	PN 16 / 25	GJS-400-18-LT - 5.3103
590-DG. ab DN 150	PN 16 / 25	Welded steel, diffusor stainless steel
590 DN 15...DN 250	PN 40	Welded steel, diffusor stainless steel

Available nozzle diameters (mm)

DN	15	25	32	40	50	65	80	100	125	150	200	250
Ø	2.5	2.5	5	6.5	8	10	12.4	16	20	25	65	80
	3.2	3.2	6.5	8	10	12.5	16	20	25	32	80	100
	4	4	8	10	12.5	16	20	25	32	40	92	120
	5	5	10	12.5	16	20	25	32	40	50		
	6.5	6.5	12.5	16	20	25	32	40	50	65		
		8				23	30	37	47	55	76	
	10											

DN 150 - DN 250: The indicated nozzle diameters are our default values. Any desired intermediate sizes are also possible (without additional cost).

Approximate weights of the baelz 590 (kg)

DN	15	25	32	40	50	65	80	100	125	150	200	250
Spheroid ductile iron	6.3	9.1	14.9	19.3	25.3	40.4	50.6	68	104.3	145	300	460
Steel	7.4	10.2	16	20.4	27	42	52.6	70	106.3	148	310	470

baelz 590 dimensions (mm)

DN	BL	h1		h2	
		PN16/25	PN40	590	590-K
15	130	175	176	109	261
25	160	202	229	110	263
32	180	302	302	104	339
40	200	358	358	114	349
50	230	402	429	124	359
65	290	539	573	144	379
80	310	600	695	154	389
100	350	624	912	204	439
125	400	1066		224	459
150	480	1364		244	234
200	600	1651		268	258
250	730	2070		398	398

Dimensions of the Baelz actuators (mm)

	L	x	Ød	l	ØD
E07	320	145	129		
E45	560	150	175		
P11				244	160
P21				268	242
P21-V6				304	242
P22				322	242
E45	577	1057	150	175	
E66	614	1094	200	188	
P31				509	989
P32				525	1005
P41				562	1042
P41-V6				687	1167

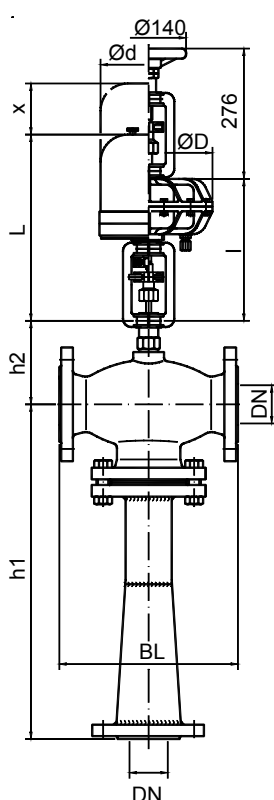

baelz 590 DN15-125

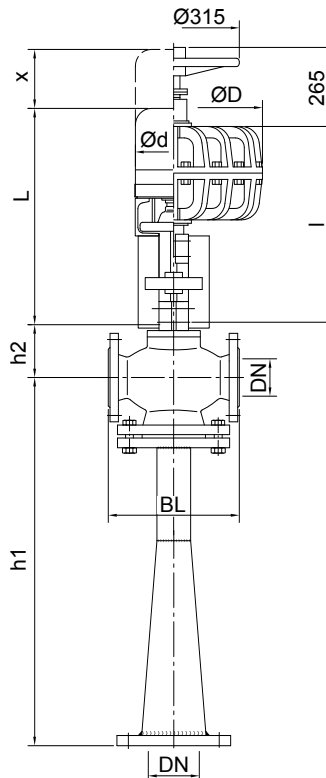

baelz 590 DN150-300

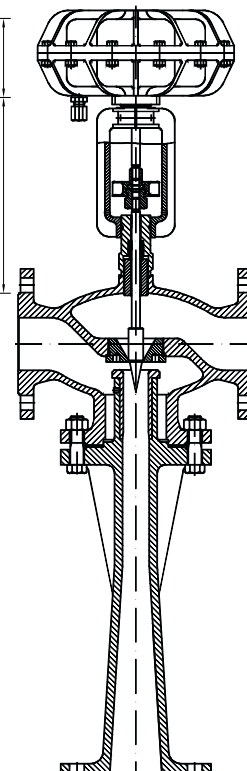

baelz 590

The differential pressures specified here are limited by the nominal pressure of the housings, if this is lower.

Electric actuators. baelz 480, 590. Plug closes in direction of flow.

Actuator	Power (N)	Nozzle Ø (mm) / Maximum differential pressure ΔPmax (bar)																
		≤ 12.5	16	20	23	25	30	32	37	40	47	50	60	65	80	90	100	120
E07-	2000	181	75	47	36	30	21	18	14	13	9.7	8.5	5.9					
E65- 11-	1100	86	36	22	17	14	10	9	6.8	6.4	4.6	4.1	2.8					
E65- 20-	2000	181	75	47	36	30	21	18	14	13	9.7	8.5	5.9					
E45-	4000			97	73	62	43	38	29	27	19	17	12	11				
E66-	15000									106	76	67	46	43	27	21	17	11
E88- 100-	10000									69	50	44	30	28	17	14	11	7.7

Pneumatic actuators. baelz 480, 590. Plug closes in direction of flow.

Actuator	Power (N)	req. feed pressure (bar)	Nozzle Ø (mm) / Maximum differential pressure ΔPmax (bar)															
			≤ 20	23	25	30	32	37	40	47	50	60	65	80	90	100	120	
P11- 1-	950	6.0	84	68	58	41	36	27										
P21- 3-	1020	3.0	141	106	90	63	56	42	40	29	25	17						
P21- 6-	2040	3.0	123	93	79	55	49	37	35	25	22	15						
P21- 6-	2040	6.0	294	223	189	133	117	89	83	60	53	36						
P22- 3-	1846	3.0							37	26	23	16	15					
P22- 6-	3692	6.0							73	52	46	32	30					
P31- 3-	2480	3.0							110	79	69	48	45					
P31- 6-	4960	3.0							93	67	59	41	38					
P31- 6-	4960	6.0							220	158	139	96	89					
P32- 6-	4402	3.0									61	42	39	25	19	15	11	
P32- 6-	4402	6.0									141	98	91	57	45	36	25	
P41- 6-	7530	6.0									281	195	180	114	89	71	49	



baelz 591

DESCRIPTION

The baelz 591 is a steam/water ejector (desuperheater) with flange connection for saturated steam generation and superheated steam cooling.

Housing: GJS-400-18-LT - 5.3103 / GP240GH - 1.0619 (PN 40)
 Plug spindle and nozzle: stainless steel

TECHNICAL SPECIFICATIONS

The plug type and the control characteristic are designed and manufactured to order.

Saturated steam generator with high control quality for load $\approx 2 - 100\%$
 Spindle seal: V-rings in PFTE
 Option: baelz 591-K - with cooling tube

Working fluids: steam / water

Leakage class (EN 1349)

metal-to-metal seal: 0.004% Kvs (better than class IV)

Stroke (mm)

DN 32 - DN 80

DN 100 - DN 125

\geq DN 150

22 / 40 mm

44 / 66 mm

Spindle Ø (mm)

10mm

16 mm

22mm

Designation	Nominal pressure	Housing material	Nominal diameter	Connection
baelz 591	PN 16 PN 25	GJS-400-18-LT - 5.3103	DN 32 - DN 200 (up to DN 400 on request)	Flange (Special model to EN 1092-1 Shapes D / E / F on request)
	PN 40 (to PN 160 on request)	GP240GH - 1.0619		

T max. (°C) / P max. (bar)*

Housing material	GJS-400-18-LT - 5.3103		GP240GH - 1.0619
Nominal pressure	PN 16	PN 25	PN 40
baelz 591 DN 32 - DN 200	240/12.3 ... 50/16	240/19.3 ... 50/25	240/30.9 ... 50/40
baelz 591-K DN 32 - DN 200	350/10.2 ... 50/16	350/16 ... 50/25	350/25.7 ... 50/40

* Higher temperatures of the working fluids to approx. 400°C on request

Approximate weights of the baelz 591 ejector (kg)

DN	32	40	50	65	80	100	125	150	200
Spheroid ductile iron	17	21	28	45	56	75	115	160	315
Steel	19	23	30	47	58	77	117	163	320

Dimensions of the baelz 591 DN 32-125 (mm)					
DN	BL	h1	h2		B
			591	591-K	
32	180	175	254	488	33
40	200	222	264	498	33
50	230	283	274	508	35
65	290	469	294	528	37
80	310	576	304	538	39
100	350	737	319	553	39
125	400	797	339	573	43

Dimensions of the baelz 591 DN 150-200 (mm)							
DN	BL	B			h1		h2
		PN16	PN25	PN40	591	591-K	
150	480	37	45	45	1116	450	434
200	600	39	47	53	1357	560	458

Dimensions of the Baelz actuators (mm)						
	L	x	Ød	l	ØD	
E07	320	145	129			
E45	560	150	175			
P11				244	160	
P21				268	242	
P21-V6				304	242	
P22				322	242	
E45	577	1057	150	175		
E66	614	1094	200	188 (258*)		
P31				509	989	384
P32				525	1005	384
P41				562	1042	506
P41-V6				687	1167	506

* with manual operation

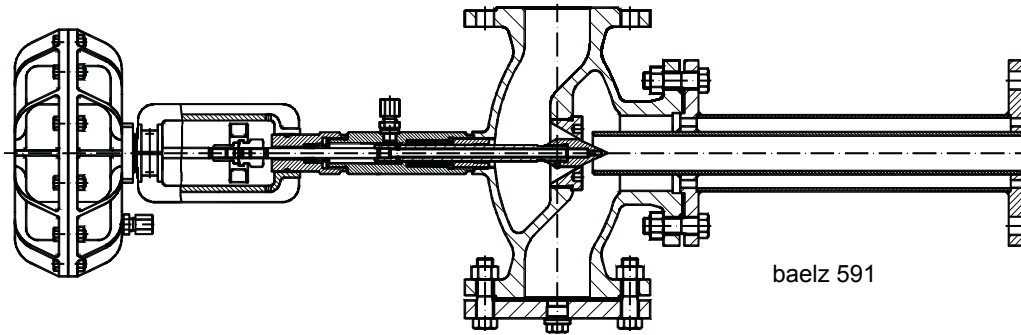
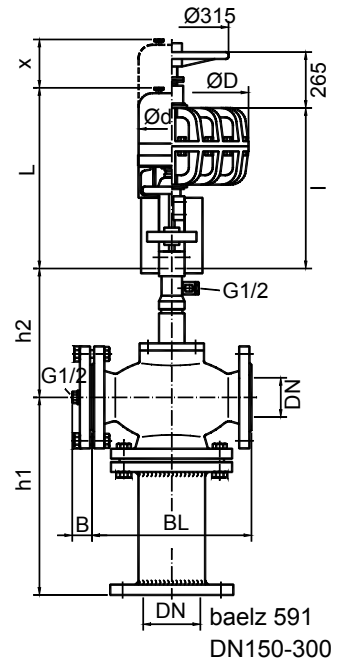
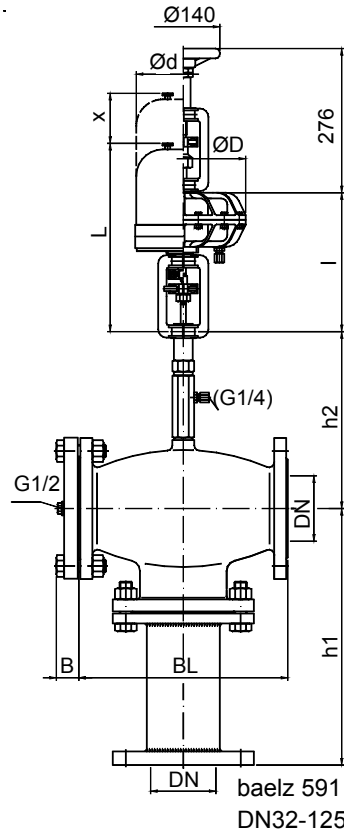

The differential pressures specified here are limited by the nominal pressure of the housings, if this is lower.

Electric actuators. baelz 591. Plug closes in direction of flow.

Actuator	Power (N)	Nozzle Ø (mm) / Maximum differential pressure ΔPmax (bar)																	
		≤ 12.5	16	20	23	25	30	32	37	40	47	50	60	65	80	90	100	120	
E07-	2000	181	75	47	36	30	21	18	14	13	9.7	8.5	5.9						
E45-	4000			97	73	62	43	38	29	27	19	17	12	11					

Pneumatic actuators. baelz 591. Plug closes in direction of flow.

Actuator	Power (N)	req. feed pressure (bar)	Nozzle Ø (mm) / Maximum differential pressure ΔPmax (bar)																
			≤ 20	23	25	30	32	37	40	47	50	60	65	80	90	100	120		
P21-	3-	1020	3.0	141	106	90	63	56	42	40	29	25	17						
P21-	6-	2040	3.0	123	93	79	55	49	37	35	25	22	15						
P21-	6-	2040	6.0	294	223	189	133	117	89	83	60	53	36						

3.1 Linear Pneumatic Diaphragm Actuators

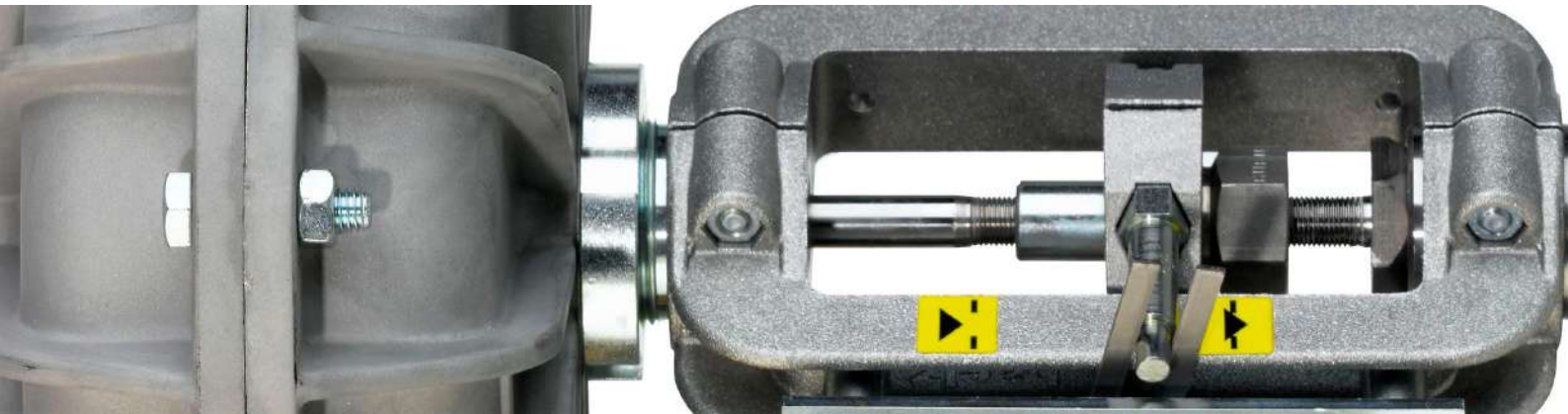

Advantages of linear pneumatic diaphragm actuators:

- fast positioning
- specified position in case of pressure failure
- powerful
- can be operated at high ambient temperatures
- can be operated in potentially explosive atmospheres
- number of springs selectable for adjustment of actuator force
- easy conversion NO / NC without special equipment
- handwheel optional

Table for selecting baelz 373-PXX actuators

Spring force, manual control (N)	Diaphragm surface (cm ²)	Max. Stroke (mm)	Type baelz 373
1020 - 4030	240	22	P21-3 to P21-18
7590	240	22	P21-V6
1846 - 3692	240	40	P22-3 to P22-6
2480 - 10560	620	44	P31-3 to P31-18
2201 - 8115	620	66	P32-3 to P32-18
3765 - 41600	1250	44, 66	P41-3 to P41-V6

Example of identification for ordering: **373-P21L-12-Fu-S21-L-H21-22mm**

baelz 373 - P XX - 12 - Fu - S21-L - H21 - 22

Actuator model (XX)			
	P21 / P21L		
	P22 / P22L		
	P31		
	P32		
	P41		
Number of springs (Z)			
	3		
	6		
	12		
	18		
	V6 -6 reinforced		
Safety function (V)			
		Fo - spindle extended	
		Fu - spindle retracted	
Yoke type (S)			
		S21 / S21-L	
		S41 / S41C	
Hand operation (H), if applicable			
			H21
			H31
			H41
Stroke (mm)			
			8, 12, 16, 22 , 40, 44, 66

page 96

baelz 373-P11



- For DN 15...125
- Stroke: 12, 16, 22 mm
- Power: 990 N
- Weight, approx.: 2.1 kg
- Temperature: 0 ... +80°C
- Humidity: 0 ... 90%
- Pressure: 1.2...6 bar
- Housing: Aluminum
- Diaphragm: NBR
- Fo/Fu-Actuator

page 97

baelz 373-P21



- For DN 15...125
- Stroke: 8, 12, 16, 22 mm
- Power: 1020...7590 N
- Weight: 5.3-8.8 kg
- Temperature: 0 ... +80°C
- Humidity: 0 ... 90%
- Pressure: 1.2...6 bar
- Housing: Aluminum
- Diaphragm: NBR

page 98

baelz 373-P22



- For DN 15...125
- Stroke: 40 mm
- Power: 1846...3692 N
- Weight: 6.3-6.6 kg
- Temperature: 0 ... +80°C
- Humidity: 0 ... 90%
- Pressure: 1.2...6 bar
- Housing: Aluminum
- Diaphragm: NBR

page 99

baelz 373-P31



- For DN 150
- Stroke: 44 mm
- Power: 2480...10560 N
- Weight: 27.7-36.5 kg
- Temperature: 0 ... +80°C
- Humidity: 0 ... 90%
- Pressure: 1.2...6 bar
- Housing: Aluminum
- Diaphragm: NBR

page 100

baelz 373-P32



- For DN 200
- Stroke: 66 mm
- Power: 4402...8115 N
- Weight: 36-43 kg
- Temperature: 0 ... +80°C
- Humidity: 0 ... 90%
- Pressure: 3...6 bar
- Housing: Aluminum
- Diaphragm: NBR

page 101

baelz 373-P41



- For DN 150...300
- Stroke: 44, 66 mm
- Power: 3765...31920 N
- Weight: 55.5-66.5 kg
- Temperature: 0 ... +80°C
- Humidity: 0 ... 90%
- Pressure: 1.2...6 bar
- Housing: Aluminum
- Diaphragm: NBR

Accessories for Linear Pneumatic Diaphragm Actuators



- Positioners
- Switches
- Pressure controllers

Direction of Action with Control Valve

Direction of action **NC** (normally closed): pressure failure → valve **closed**
 Direction of action **NO** (normally open): pressure failure → valve **open**

The actuator has the following directions of action:

- Fu/SB** (spring below) → in case of air/power supply failure **actuator retracts spindle**
- Fo/SA** (spring above) → in case of air/power supply failure **actuator extends spindle**

The valve has 2 optional closing directions: *spindle retracted* = valve closed and *spindle extended* = valve closed.

The combinations resulting from these options are shown below.

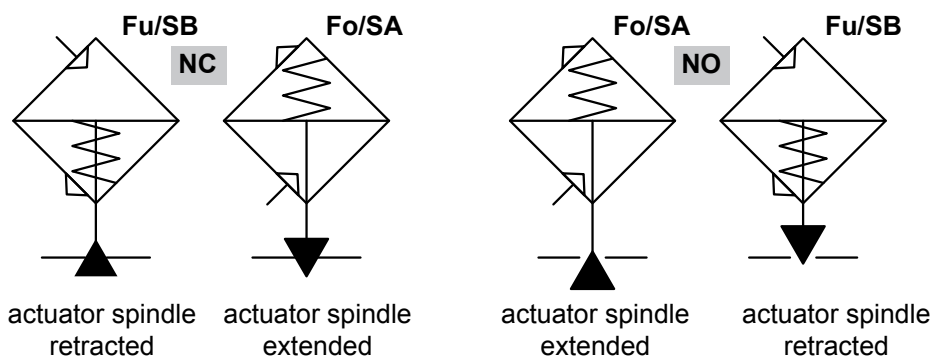



baelz 373-P11
Fo version
(spring above)

baelz 373-P11

DESCRIPTION

baelz 373-P21 compact pneumatic linear actuators with aluminum housing EN AC-AISI9Cu3(Fe) and NBR diaphragm. For control valves up to DN 65.

TECHNICAL SPECIFICATIONS

Ambient conditions: temperature: 0 ... +80° C;
relative humidity: 0 ... 90%
Max. supply air pressure: 6 bar
Air connection: push-in fitting for tube Ø 8 mm
Yoke and coupling made of aluminum, fasteners made of zinc plated steel.
Stroke: 12, 16, 22 mm
Number of springs: 1

OPTIONS

Special Feature: Fo/Fu-Actuator

Fo (spring above) or Fu (spring below) depends upon which way up the actuator is mounted, so Fo or Fu can be selected with no need for dismantling the actuator. Components used remain identical for Fo and Fu.

Fo = Spring above: spindle extended is normal position. The springs extend the spindle, compressed air retracts the spindle.

Fu = Spring below: spindle retracted is normal position. The springs retract the spindle, compressed air extends the spindle.

Yoke options:

S21 yoke (standard) - for valves with spindle Ø10 mm

Designation	Options				
	Valve Spindle Ø (mm)	Force (N)	Min. supply air pressure (bar)	N ^o . springs	Weight, approx. (kg)
P11-1-Fo/Fu	10	950	1.2	1	2.1

baelz 373-P11 dimensions (mm)

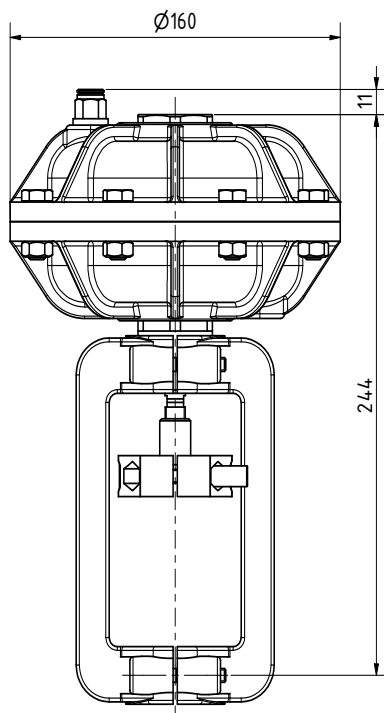



baelz 373-P21

DESCRIPTION

baelz 373-P21 compact pneumatic linear actuators with aluminum housing EN AC-AISI9Cu3(Fe) and NBR diaphragm. For control valves up to DN 125.

TECHNICAL SPECIFICATIONS

Ambient conditions: temperature: 0 ... +80° C;
 relative humidity: 0 ... 90%
 Max. supply air pressure: 6 bar
 Air connection: push-in fitting for tube Ø 8 mm
 Yoke and coupling made of aluminum (P21L: coupling zinc plated steel), fasteners made of zinc plated steel.
 Stroke: 8, 12, 16, 22 mm
 Number of springs: 3, 6, 12, 18 or 6 reinforced (V6)

OPTIONS

Fo = Spring above: spindle extended is normal position. The springs extend the spindle, compressed air retracts the spindle.
Fu = Spring below: spindle retracted is normal position. The springs retract the spindle, compressed air extends the spindle.
Manual operation:
 P21-H21 (for 3, 6, 12, 18 spring) - handwheel Ø120 mm
 P21-V6-H21 (for reinforced spring) - handwheel Ø 200 mm

Yoke options:

S21 yoke (standard) - for valves with spindle Ø10 mm
 S21-L yoke - for valves with spindle Ø16 mm
 S23 yoke - spindle Ø10 mm (für high differential pressures)
 S23L yoke - spindle Ø16 mm (für high differential pressures)

Designation	Valve Spindle Ø (mm)	Options			Weight, approx. (kg)
		Force (N)	Min. supply air pressure (bar)	N ^o . springs	
P21-3-Fo/Fu	10	1020	1.2	3	5.3
P21L-3-Fo/Fu	16				
P21-6-Fo/Fu	10	2040	3	6	5.6
P21L-6-Fo/Fu	16				
P21-12-Fo/Fu	10	3390	6	12	5.9
P21L-12-Fo/Fu	16				
P21-18-Fo/Fu	10	4030	6	18	6
P21L-18-Fo/Fu	16				
P21-V6-Fo/Fu	10	7590	6	6	8.8
P21L-V6-Fo/Fu	16				
+H21					+2

Extras	Order number
Mechanical stroke limitation	MP373-P21-1411
Silicone membrane, Ambient temperature 0...100 °C	MP373-P21-501
Polyester coated inside and out, black, for hydraulic operation, includes coating of yoke. With stainless steel fittings and yoke connection. Ambient temperature max. 50 °C	MP373-P21-521
Special coating, FDA approved, includes coating of yoke. With stainless steel fittings and yoke connection.	MP373-P21-531

baelz 373-P21 dimensions (mm)

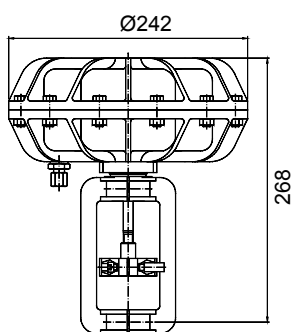

Actuator baelz 373-P21-S21

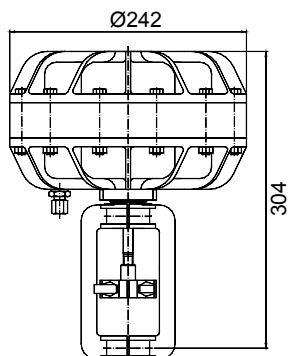

Actuator baelz 373-P21-V6-S21

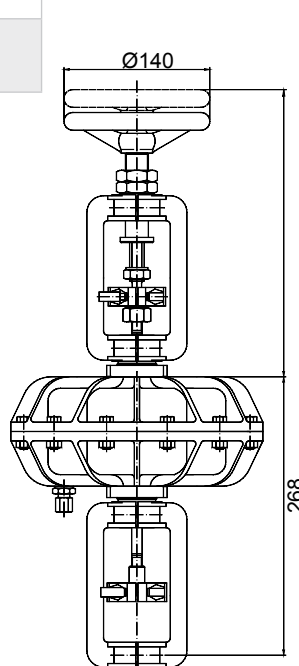

baelz 373-P21-S21-H21

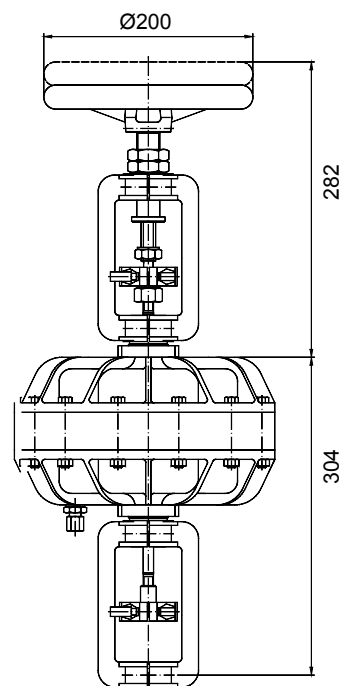

baelz 373-P21-V6-S21-H21



baelz 373-P22

DESCRIPTION

baelz 373-P21 compact pneumatic linear actuators with aluminum housing EN AC-AISI9Cu3(Fe) and NBR diaphragm. For control valves up to DN125.

TECHNICAL SPECIFICATIONS

Ambient conditions: temperature: 0 ... +80°C;
 relative humidity: 0 ... 90%
 Max. supply air pressure: 6 bar
 Air connection: push-in fitting for tube Ø 8 mm
 Yoke and coupling made of aluminum (P22L: coupling zinc plated steel), fasteners made of zinc plated steel.

Stroke: 40 mm
 Number of springs: 3, 6

OPTIONS

Fo = Spring above: spindle extended is normal position. The springs extend the spindle, compressed air retracts the spindle.
Fu = Spring below: spindle retracted is normal position. The springs retract the spindle, compressed air extends the spindle. **Manual operation:**
 P22-H22 - handwheel Ø 120 mm
Yoke options:
 S21 yoke (standard) - for valves with spindle Ø10 mm
 S21-L yoke - for valves with spindle Ø16 mm

Options					
Designation	Valve Spindle Ø (mm)	Force (N)	Min. supply air pressure (bar)	N ^o . springs	Weight, approx. (kg)
P22-3-Fo/Fu	10	1846	6	3	6.3
P22L-3-Fo/Fu	16				
P22-6-Fo/Fu	10	3692	6	6	6.6
P22L-6-Fo/Fu	16				
+H22					+2

Extras	Order number
Polyester coated inside and out, black, for hydraulic operation, includes coating of yoke. With stainless steel fittings and yoke connection. Ambient temperature max. 50 °C	MP373-P22-522

baelz 373-P22 dimensions (mm)

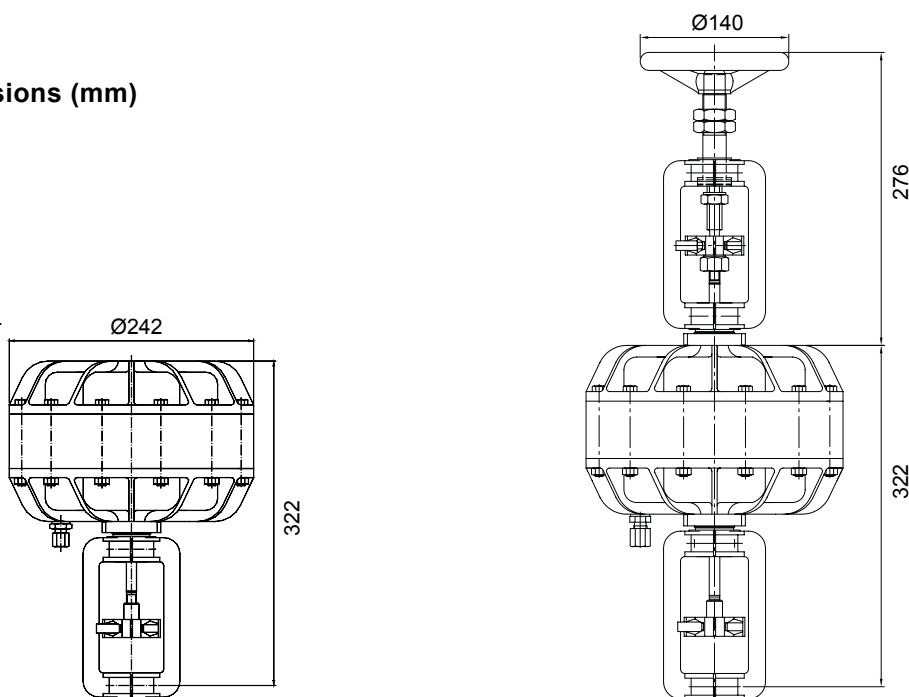

Actuator baelz 373-P22-S21

Actuator baelz 373-P22-S21-H22 (with handwheel)



baelz 373-P31

DESCRIPTION

baelz 373-P31 compact pneumatic linear actuators with aluminum housing EN AC-AISI9Cu3(Fe) and NBR diaphragm. For DN 150 control valves.

TECHNICAL SPECIFICATIONS

Ambient conditions: temperature: 0 ... +80° C;
 relative humidity: 0 ... 90%
 Max. supply air pressure: 6 bar
 Air connection: push-in fitting for tube Ø 8 mm
 Yoke, coupling and fasteners made of zinc plated steel.
 Stroke: 44 mm
 Number of springs: 3, 6, 18

OPTIONS

Fo = Spring above: spindle extended is normal position. The springs extend the spindle, compressed air retracts the spindle.
Fu = Spring below: spindle retracted is normal position. The springs retract the spindle, compressed air extends the spindle.
Manual operation:
 P31-H31 - handwheel Ø 315 mm
Yoke options:
 S41 - for valve control without cooling tube
 S41C - for valve control with cooling tube

Options					
Designation	Valve Spindle Ø (mm)	Force (N)	Min. supply air pressure (bar)	Nº. springs	Weight, approx. (kg)
P31-3-Fo/Fu-S41	Ø 22	2480	1.2	3	27.7
P31-3-Fo/Fu-S41C					31.7
P31-6-Fo/Fu-S41		4960	3	6	29.5
P31-6-Fo/Fu-S41C					33.5
P31-18-Fo/Fu-S41		10560	6	18	32.5
P31-18-Fo/Fu-S41C + H31					36.5
		-			+11

baelz 373-P31 dimensions (mm)

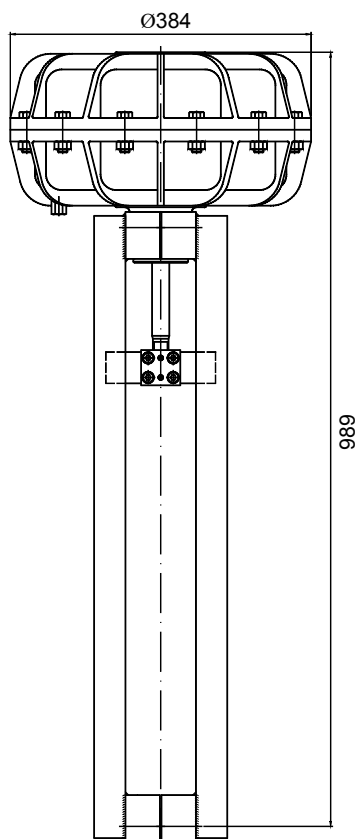

Actuator baelz 373-P31-S41C

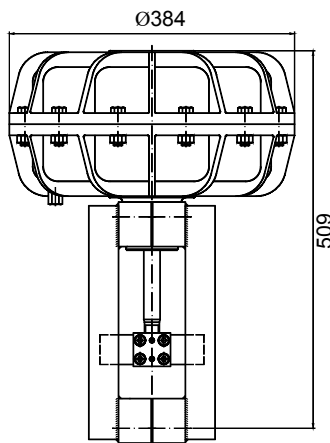

Actuator baelz 373-P31-S41

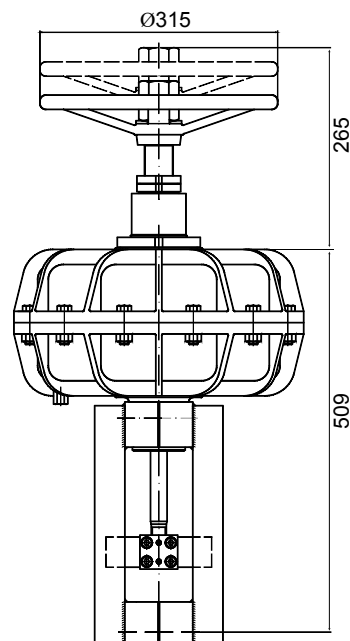

Actuator baelz 373-P31-S41-H31



baelz 373-P32

DESCRIPTION

baelz 373-P32 compact pneumatic linear actuators with aluminum housing EN AC-AISI9Cu3(Fe) and NBR diaphragm. For control valves sized DN 200 and upwards.

TECHNICAL SPECIFICATIONS

Ambient conditions: temperature: 0 ... +80°C;
 relative humidity: 0 ... 90%
 Max. supply air pressure: 6 bar
 Air connection: push-in fitting for tube Ø 8 mm
 Yoke, coupling and fasteners made of zinc plated steel.
 Stroke: 66 mm
 Number of springs: 3, 6, 18

OPTIONS

Fo = Spring above: spindle extended is normal position. The springs extend the spindle, compressed air retracts the spindle.
Fu = Spring below: spindle retracted is normal position. The springs retract the spindle, compressed air extends the spindle.
Yoke options:
 S41 - for valve control without cooling tube
 S41C - for valve control with cooling tube

Designation	Options				Weight, approx. (kg)
	Valve Spindle Ø (mm)	Force (N)	Min. supply air pressure (bar)	Nº. springs	
P32-3-Fo/Fu-S41	Ø 22	2201	3	3	34.2
P32-3-Fo/Fu-S41C					38.2
P32-6-Fo/Fu-S41		4402	3	6	36
P32-6-Fo/Fu-S41C					40
P32-18-Fo/Fu-S41		8115	6	18	39
P32-18-Fo/Fu-S41C					43

baelz 373-P32 dimensions (mm)

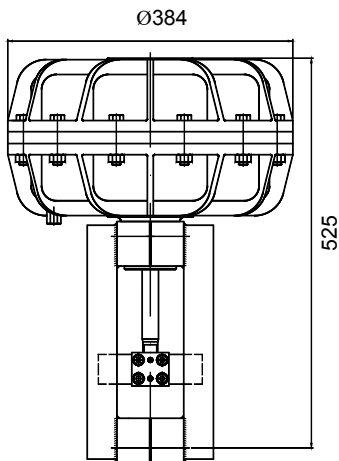

Actuator baelz
373-P32-S41



baelz 373-P41

DESCRIPTION

baelz 373-P41 compact pneumatic linear actuators with aluminum housing EN AC-AISI9Cu3(Fe) and NBR diaphragm. For control valves sized DN 150 and upwards.

TECHNICAL SPECIFICATIONS

Ambient conditions: Temperature: 0 ... +80° C;
 relative humidity: 0 ... 90%
 Max. supply air pressure: 6 bar
 Air connection: push-in fitting for tube Ø 8 mm
 Yoke, coupling and fasteners made of zinc plated steel.
 Stroke: 44, 66 mm
 Number of springs: 3, 6, 6 reinforced (V6)

OPTIONS

Fo = Spring above: spindle extended is normal position. The springs extend the spindle, compressed air retracts the spindle.
Fu = Spring below: spindle retracted is normal position. The springs retract the spindle, compressed air extends the spindle.
Manual operation:
 P41-H41 - handwheel Ø 315 mm
Yoke options:
 S41 - for valve control without cooling tube
 S41 - for valve control with cooling tube

Designation	Options				Weight, approx. (kg)
	Valve Spindle Ø (mm)	Force (N)	Min. supply air pressure (bar)	Nº springs	
P41-3-Fo/Fu-S41	Ø 22	3765	1.2	3	55.5
P41-3-Fo/Fu-S41C					59.5
P41-6-Fo/Fu-S41		7530	3	6	58.5
P41-6-Fo/Fu-S41C					62.5
P41-V6-Fo/Fu-S41		31920	6	V6	65,0
P41-V6-Fo/Fu-S41C					69,0
+ H41		-			+11

baelz 373-P41 dimensions (mm)

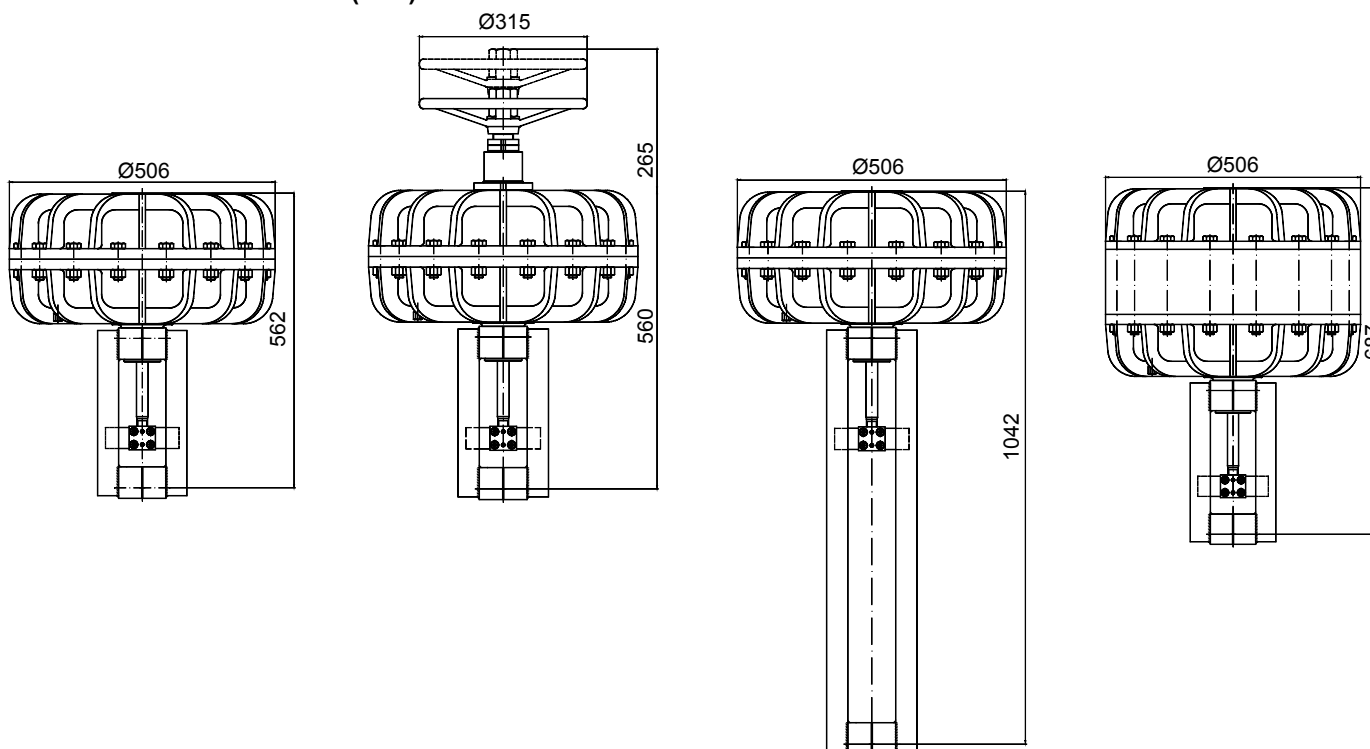

Actuator baelz 373-P41-S41

Actuator baelz 373-P41-S41-H31

Actuator baelz 373-P41-S41C

Actuator baelz 373-P41-V6-S41



baelz 87

DIGITAL I/P POSITIONER

The baelz 87 electro-pneumatic positioner compares an electrical actuating signal with the stroke of the pneumatic valve and thus regulates the required actuating pressure.

ADVANTAGES AT A GLANCE

- Easy operation with menu navigation and capacitive buttons
- Preset parameters, individually customizable if required
- Power-fail-safe storage of all parameters in the EEPROM
- Optional accessories: assembly kit, manometer attachment kit

Options

87	without explosion protection
87-Ex	ATEX: II 2 G Ex ia IIC T4 / STCC: 0 Ex ia IIC T4 X
87-Ex-CSA	CSA: Ex ia IIC T4; Class I, Zone 0, AEx ia IIC T4; Class I, Div. 1, Groups A, B, C & D
87- ...	without mounting
87- ... -M	including mounting on baelz 373-P pneumatic actuator ...
Complete adaptation parts	Assembly package as replacement or for retrofitting, weight approx. 0.2 kg
Manometer mounting kit	including 2 manometers Ø 40 mm, display range: 0 ... 10 bar

baelz 87 positioner - technical specifications

Input signal	4 ... 20mA (2-wire)
Fluid	Compressed air according to ISO 8573-1 - Particle content: Class 4; Oil content: Class 3
Air pressure	Max. 1.7 ... 7 bar (actuating pressure for linear actuators 6 bar)
Ventilate actuator flow	3.0 m _n ³ /h at 1.4 bar; 8.5 m _n ³ /h at 6 bar
Dearate actuator flow	4.5 m _n ³ /h at 1.4 bar; 14.0 m _n ³ /h at 6 bar
Air consumption	< 0.1 m _n ³ /h to 6 bar
Housing / cover	Polyphthalamide (PPA) / polycarbonate (PC)
IP rating	IP 66
permissible ambient temp.	- 20 ... + 80°C (see also Ex approval)
Cable gland	Polyamide (PA), black, M20 x 1.5
Connecting thread	G 1/4, internal thread
Stroke	12...66 mm
Weight	approx. 0.7 kg

baelz 87 dimensions (mm)

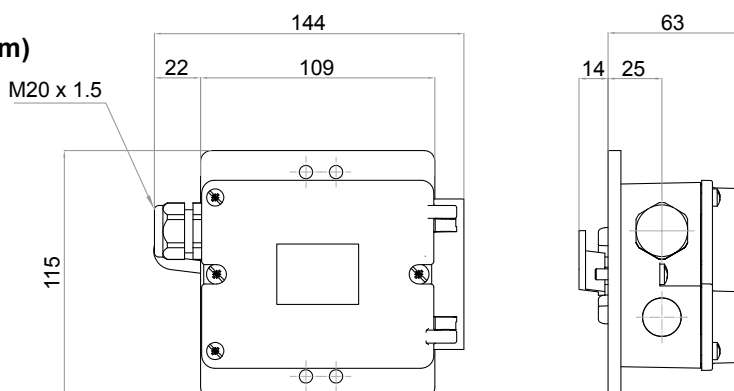



baelz 88

I/P POSITIONER

The baelz 88 electro-pneumatic positioner compares an electrical actuating signal with the stroke of the pneumatic valve and thus regulates the required actuating pressure.

ADVANTAGES AT A GLANCE

- Easy operation with three keys with two-line display
- Preset parameters, individually customizable if required
- Distance measurement with lever system and internal rotary potentiometer
- Position feedback 0/4 ... 20 mA or 0 ... 10 V optional
- Mounting parts or assembly optional

baelz 88 positioner - technical specifications

Device	88-Sp400	88-Sp401	88-Sp400-EEEx	88-Sp401-EEEx	88-8792
Housing	Polycarbonate	Aluminium GD-AISI12	Polycarbonate	Aluminium GD-AISI12	Aluminium, plastic coated
IP rating	IP 66 (EN 60529) NEMA 4 X				IP 65 (EN 60529)
Explosion protection	-	II2G EEEx ia/ib IIC T4/T6* Zone 1 Class I, div. 1, Groups A, B, C, D Class I, Zone 1 AEx (FM) Ex(CSA) ib IIC		-	-
Input signal	4...20mA (2-wire)				0/4...20mA oder 0...10V (4-wire) ***
Position feedback* (optional)	see table of "Optional extras and accessories for baelz 88-Sp40X devices"				for baelz 88-8792-i 0/4...20mA or 0...10V (4-wire) ***
Current to maintain auxiliary power	≥ 3,6 mA				
Ambient / operating temperature	-30 ... +80 °C**	-30 ... +80 °C**	-30 ... +50 °C**	-30 ... +50 °C**	0 ... +60 °C
Supply air pressure	1,4 ... 6 bar				
Air quality acc. to ISO 8573-1*	Particles: Class 3 Pressure dew point: Class 3 Oil content: Class 3				Particles: Class 7 Press. dew point: Class 3 Oil content: Class X
Steady state internal air consumption	0,036 m³/h				no internal air consumption
Electrical connection	M 20 x 1,5				2 x M 20 x 1,5 screw terminals
Pneumatic connection	G ¼ sleeve connection				
Dimensions	182 x 95 x 97 mm				171 x 100 x 110 mm
Weight, approx.	without fitting set	0.9	1.3	0.9	1.3
	with fitting set	1.8	2.2	1.8	2.2
Stroke	8 ... 22 mm / 40 ... 66 mm				max. 22/max. 66 mm
Assembly and fitting set (optional)	Suffix "-M" is added to type number (actuator not included in price)				

* With position feedback option only T4 valid
 ** At ≤ -10 °C limited display refresh rate of the LCD
 *** Please state desired signal when ordering

Air throughput for baelz 88-Sp40X devices			
Throughput m³/h at	2 bar	4 bar	6 bar
Air supply valve	4.1	7.1	9.8
Exhaust air valve	8.2	13.7	19.2

	Burden voltage (□ Ω at 20 mA)	
	without HART	with HART
88-Sp400 / 88-Sp401	max. 6.48 V (□ 324 Ω)	max. 6.72 V (□ 336 Ω)
88-Sp400-EEEx / 88-Sp401-EEEx	max. 8.3 V (□ 415 Ω) Int. capacitance Ci: ≤ 22 nF Internal inductivity: ≤ 0.12 mH	max. 8.3 V (□ 415 Ω) Int. capacitance Ci: ≤ 7 nF Internal inductivity: ≤ 0.12 mH

Optional extras and accessories for baelz 88-Sp40X devices		
Type	Designation	Description
MP88-i	Position feedback	40...20 mA, auxiliary supply +12...+35 V DC
MP88-i-Ex	Position feedback explosion protection II2G EEx ia/ib IIC T4 Zone 1	40...20 mA, auxiliary supply +12...+35 V DC
MP88-K	Limit contact module	includes: 1 binary (transistor) output for a collective error message, max. 35 V DC 2 switches to report on 2 mechanically selectable limit values max. contact load 250 V AC or 24 V DC; max. current AC/DC 4 A
MP88-K-Ex	Threshold contact module explosion protection II2G EEx ia/ib IIC T6 Zone 1	includes: 1 binary (transistor) output for a collective error message, max. 8,2 V DC 2 switches to report on 2 mechanically selectable limit values max. contact load 30 V DC; max. current AC/DC 100 mA; max. output 750 mW
MP88-MB	pre-fitted manometer block	G ¼, manometer Ø 40 mm; including: 1 manometer: 0...6 bar 1 manometer: 0...10 bar Please note: max. air pressure for use with our pneumatic diaphragm actuators 373-P: 6 bar
MP88-ProfiB-PA	Profi-Bus-PA interface	- Connection to the central control system must be carried out by the customer - A DA/PA coupler (not included) may be necessary
ZB88-T-22 mm	Full fitting set, stroke 8...22	including lever fitting set for positioner (as a spare or for retrofitting) Weight approx. 0.9 kg, for stroke 8...22 mm
ZB88-T-22 mm	Full fitting set, stroke 40...66	including lever fitting set for positioner (as a spare or for retrofitting) Weight approx. 0.9 kg, for stroke 40...66 mm
ZB88-BT-40 mm	Full fitting set	from actuator yoke to lever fitting set for positioner; includes tubing and fitting materials, but not including lever fitting set Weight approx. 0.4 kg; suitable for actuator yokes S21/S21L; for stroke 8...40 mm

Accessories for baelz 88-8792		
Type	Designation	Description
ZB88-8792-T	Fitting set	for fitting the positioner to Baelz pneumatic actuators 373-P.. (already included in device types with "M" = including assembly and fitting set) Assembly and actuator are not included in the price Note: Electrical power supply, see baelz 6208...

Example of type designation: **baelz 88-Sp400-EEx-H-22 mm-M**

baelz - 88-Sp400 - EEx - H - 22 mm - M

Series	Explosion protection	With HART	With position feedback	Stroke	Including assembly and fitting set
88-Sp400				22 mm	
88-Sp401				66 mm	
88-8792	EEx	H	i		M
Explosion protection (not for 88-8792)					
With HART (not for 88-8792)					
With position feedback (only for 88-8792-i, otherwise as optional extra)					
Stroke					
8...22 mm / max. 22 mm					
40...66 mm / max. 66 mm					
Including assembly and fitting set					

Mechanical limit switches

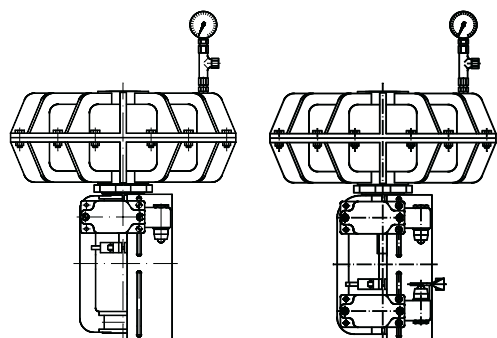
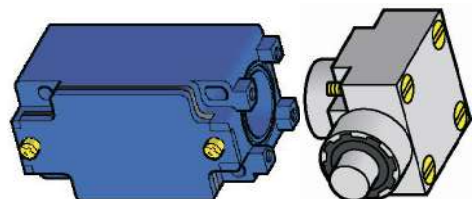

baelz 376-1PEZA
for 373-P21

baelz 376-2PEAZ
for 373-P21

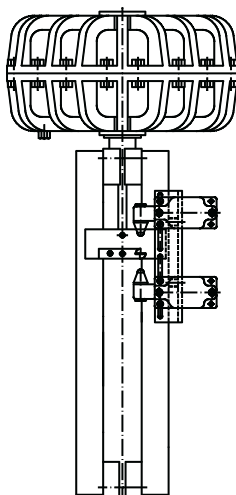

baelz 376-2PEAZ
for 373-P31/P41

baelz 376-P...PEZ

TECHNICAL SPECIFICATIONS

Standard model

1PEZA: 1 limit switch position "open" (weight. 0.3 kg)
 1PEZZ: 1 limit switch position "closed" (weight. 0.3 kg)
 2PEAZ: 2 limit switch positions "open/closed"
 (weight 0.6 kg)
 IP rating: IP 65
 Ambient temperature: -25° C ... + 70° C (operation)
 For 373-P21/P22 with stroke: 12, 16, 22 and 40 mm
 For 373-P31 with stroke: 44 and 66 mm

Rated current: AC-15 at 240 / 24V, 3A
 Dimensions W x H x D (mm): 44 x 40 x 110

Explosion-proof model

1PEZA-Ex. 1PEZZ-Ex. 2PEAZ-Ex
 Version: II 2 G EExd II CT6 / II 2 D IP 66 T80° C
 IP rating: IP 66
 Ambient temperature: -20 ... + 40° C (operation)

Inductive proximity switches (contactless)

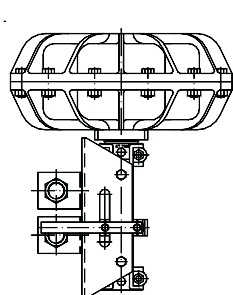
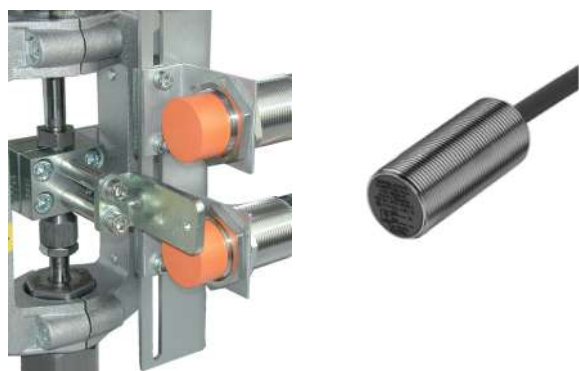

baelz 376-INIAZ-PF
for 373-P21

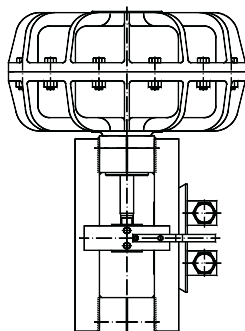

baelz 376-INIAZ-PF
for 373-P31/P41

baelz 376-P...INI

TECHNICAL SPECIFICATIONS

Inductive proximity switches including fitting set and assembly

11NIA-PF: 1 limit switch position "open" (weight. 0.3 kg)
 11NIZ-PF: 1 limit switch position "closed" (weight. 0.3 kg)
 21NIAZ-PF: 2 limit switch position "open/closed" (weight. 0.6 kg)
 Switching distance: 5 mm; Operating voltage 5 ... 25 V; Rated current 1 ... 4 mA
 Ambient temperature -25 ... 100° C; Cable polyvinyl chloride (PVC), 2 m
 Conductor cross section 0.75 mm²
 Housing material: stainless steel. M18 x 1
 Two-wire connection according to DIN 19234 (NAMUR)
 IP rating IP67
 Note: In conjunction with baelz 465-KFAA6 ex-intrinsically safe (EExia) II C.

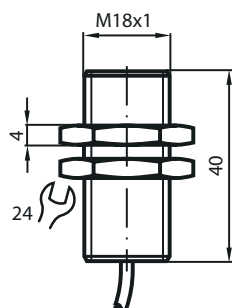

Mounting dimensions

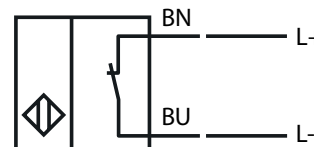

Cable connections

baelz 54298 diaphragm pressure controller with built-in filter/strainer and manometer



baelz 54298 filter pressure reducer, with baelz 340-2-B valve and P21 pneumatic actuator, a positioner with two manometers and baelz 268 solenoid valve

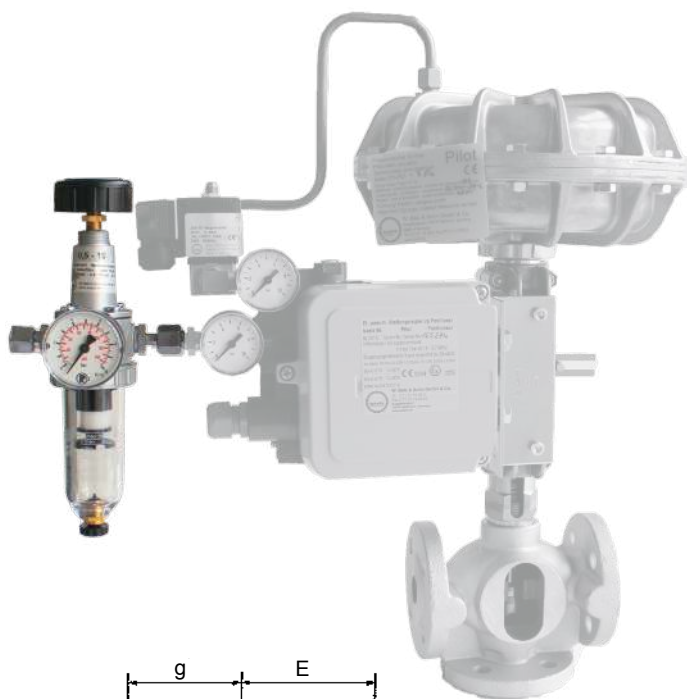

baelz 54298

TECHNICAL SPECIFICATIONS

baelz 54298 diaphragm pressure controller with built-in filter

Input air pressure: up to 16 bar Output air pressure: 0.5 ... 10 bar with the manometers:

Model 54298/1: Ø50 mm G1/4"

Housing: cast zinc

Internal parts: brass / stainless steel

Filter/strainer material: polycarbonate

Weight, approx.: 1.8 kg

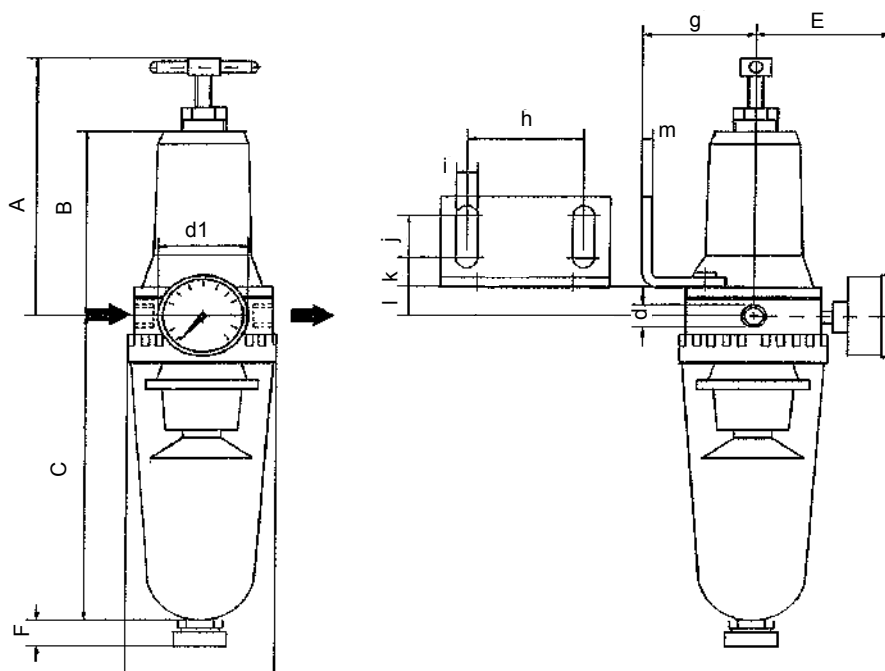

baelz 54298 dimension table

	54298 1/4" (mm)
A	100
B	62
C	119
D	57
E	60
F	20
d	G 1/4"
g	35
h	30
i	6.3
j	18
k	7
l	21
m	2
d1	50



Table for selecting the baelz 373-EXX actuators

Actuating force (N)	Actuating speed (mm/min)	Max. Stroke (mm)	Type baelz 373		Valve nominal diameter DN
100	1 / 3.7	5.5	ESI	Small actuators	for baelz 474. 475. 500...
500	10 / 20	7.5	ESA		for baelz 475
700 / 2000	130 / 6 - 18	22	E07	Standard actuators	15 - 25
1100 / 2000	10, 15, 30	40	E65		to 125
4000	15	44	E45		15 - 150
8000 / 15000	25 / 22	16 - 80	E66		150 - 300
500 - 5000	5 - 30	60	Ex-Run	Special actuators	for spindle Ø 10 / 16
4400	152.4	50	E63		150
7000 - 14000	39 - 78	65	E64		150 - 300
10000 - 40000	22 / 96	40 / 66	E88		65 - 125

Example of identification for ordering: **373-E45-40-15-S21-FgA-16mm-230**

baelz 373
- E45
- 40
- 15
- S21
- FgA
- 16mm
- 230

Actuator model (XX)					
example: (for all models see Product overview or table above)	ESI				
	E07				
	E45				
	E66				
Propelling force (N)					
		20 (2000 N)			
		40 (4000 N)			
		80 (8000 N)			
		150 (150000 N)			
Actuating speed (mm/min)					
example: (for positioning speeds see Product overview or table above)			6		
			15		
			22		
			96		
Yoke type (S)					
			S21 , S21-L		
			S23, S23L		
			S41, S41C		
For optional accessories, see the options for the particular actuator					
				XX	
Stroke (mm)					
					5.5, 7.5, 12, 16 , 22, etc.
Supply voltage (V)					
					230V 50/60 Hz AC
					115V 50/60 Hz AC
					240V 50/60 Hz AC
					24V DC

page 110

baelz 373-ESI



- For radiator valves and small ejectors
- Stroke: max 5.5 mm
- Actuating force: 100 N
- Power consumption: 1, 2, 6 VA
- Actuating speed: 1 / 3.7 mm/min
- Supply voltage: 24 / 230V
- Weight, approx.: 0.4 kg
- Temperature: +1 ... +50°C
- Humidity: 5 ... 85 %
- IP rating: IP40
- Housing: plastic

page 111

baelz 373-ESA



- For small ejectors
- Stroke: max 7.5 mm
- Actuating force: 500 N
- Power consumption: 4/8 VA
- Actuating speed: 10 / 20 mm/min
- Supply voltage: 24 / 230V
- Weight, approx.: 1 kg
- Temperature: 0 ... +50°C
- IP rating: IP54
- Housing: plastic
- Delivery incl. matching adapter

page 112

baelz 373-E07



- For DN 15...125
- Stroke: max 22 mm
- Actuating force: 700 / 2000 N
- Power consumption: 4.1 / 12 VA
- Actuating speed: 6; 18 mm/min
- Supply voltage: 24 / 115 / 230 V
- Weight, approx.: 2.2 kg
- Temperature: 0 ... +50°C
- Humidity: 0 ... 75 %
- IP rating: IP42 (IP65)
- Cover: plastic

page 115

baelz 373-E07-OSD/OSZ



- For DN 15...80
- Stroke: max 22 mm
- Actuating force: 700 N
- Power consumption: max. 30 VA
- Actuating speed: 6 / 10 / 25 / 70 / 130 mm/min
- Supply voltage: 24 / 100 / 230 V
- Weight, approx.: 3 kg
- Temperature: 0 ... +50 °C
- Humidity: 0 ... 90 %
- IP rating: IP42
- Cover: plastic

baelz 373-Ex-Run



- For spindle Ø 10 / 16 mm
- Stroke: max 60 mm
- Actuating force: 50-5000 N
- Power consumption: 11 / 64 VA
- Actuating speed: 15; 40 mm/min
- Supply voltage: 24 ... 230 V AC/DC
- Weight, approx.: 7 kg
- Temperature: -20 ... +40°C
- IP rating: IP66
- Housing: aluminum, painted
- Further information on request

page 117

baelz 373-E45



- For DN 15...150
- Stroke: max 44 mm
- Actuating force: 4000 N
- Power consumption: 11 VA
- Actuating speed: 15 mm/min
- Supply voltage: 24 / 115 / 230 V
- Weight, approx.: 8 kg
- Temperature: 0 ... 50°C
- Humidity: 0 ... +75 %
- IP rating: IP65
- Cover: plastic

baelz 373-E63



- For DN 150
- Stroke: max 50 mm
- Actuating force: 4400 N
- Actuating speed: 152.4 mm/min
- Supply voltage: 24/110...230 V
- Weight, approx.: 48.5 kg
- Temperature: -30 ... +70°C
- IP rating: IP68
- Housing: aluminum, powder-coated
- Further information on request

baelz 373-E64



- For DN 150 ...300
- Stroke: max 65 mm
- Actuating force: 7000-14000 N
- Power consumption: max. 93 VA
- Actuating speed: 39-78 mm/min
- Supply voltage: 230V
- Weight, approx.: 12 kg
- Temperature: -20 ... +60°C
- IP rating: IP67
- Housing: Aluminum, color coated
- Further information on request

baelz 373-E65



- For DN to 125
- Stroke: max 40 mm
- Actuating force: 1100 / 2000 N
- Power consumption: 18 / 20 VA
- Actuating speed: 10/15/30 mm/min
- Supply voltage: 24 / 100 / 230 V
- Weight, approx.: 5.6 kg
- Temperature: -10 ... +55°C
- Humidity: 0 ... 95 %
- IP rating: IP66
- Housing: plastic

baelz 373-E66



- For DN 150...300
- Stroke: max 80 mm
- Actuating force: 8000 / 15000 N
- Power consumption: 25 / 34 VA
- Actuating speed: 25 / 22 mm/min
- Supply voltage: 24 / 115 / 230 V
- Weight, approx.: 13 kg
- Temperature: 0 ... +50°C
- Humidity: 0 ... 75 %
- IP rating: IP65
- Cover: steel, painted

baelz 373-E88



- For DN 150...300
- Stroke: max 80 mm
- Actuating force: 8000 / 15000 N
- Power consumption: 34 VA
- Actuating speed: 22; 25 mm/min
- Supply voltage: 24...230 V
- Weight, approx.: 2.2 kg
- Temperature: -10 ... +50°C
- Humidity: 0 ... 75 %
- IP rating: IP65
- Cover: steel, painted
- Further information on request

baelz 375-E42



- Rotary actuator
- Angle of rotation: 90°
- Torque: 150 Nm
- Power consumption: 65 VA
- Actuating speed: 60 s/90°
- Supply voltage: 230 V
- Weight, approx.: 7.5 kg
- Temperature: 0 ... +50 °C
- Humidity: 0 ... 75 %
- IP rating: IP65
- Cover: plastic, gray

Built-in Controllers for Electric Actuators

- baelz 7164
- baelz 7020
- baelz 7020A

baelz 373-ESI

DESCRIPTION

Electric actuator for baelz 474, 475 and baelz 500 ... 507.

TECHNICAL SPECIFICATIONS

Stroke: 5.5 mm
 Housing: plastic
 IP rating: IP 40
 Thrust: 100 N
 Weight, approx.: 0.4 kg (0.5 kg with auxiliary switch)
 Thread connection: union nut M30 x 1.5 mm (or with M30 x 1.0 adapter)
 Electrical connection: 3-core connection cable with 1.5 m plug (L15) or optionally: 3-core connection cable 4.5 m, with plug; 3-pole terminal block connector with screw connection (ESI-61, ESI-81)

Ambient conditions:
 Temperature: +1 ... +50°C; Relative humidity: 0 ... 85%



Type	Actuating speed (s / 5.5 mm stroke)	Control	Media temp. (°C)	Supply voltage	max. power consumption (VA)	Parallel operation*	Auxiliary switch**
373-ESI-31	380	3-point	1 ... 110 °C	230 V AC ± 15 %, 50/60 Hz	6	max. 6	optional
373-ESI-61	90	DC 0-10 V	1 ... 100 °C	24 V AC ± 20 %, 50/60 Hz 24 V DC, ± 25 %	2	max. 10	-
373-ESI 81	350	3-point	1 ... 110 °C	24 V AC ± 20 %, 50/60 Hz	0.8	max. 24	optional

* Number of actuators for parallel operation, if the output power of the controller is sufficient

** Designation actuators with optional auxiliary switch: 373-ESI-31.1, 373-ESI-81.1

Switching point adjustable 0 ... 100%, factory setting: 50%

Switching capacity max. 250 V AC, 1 A (0.5 A)

Retrofitting not possible!

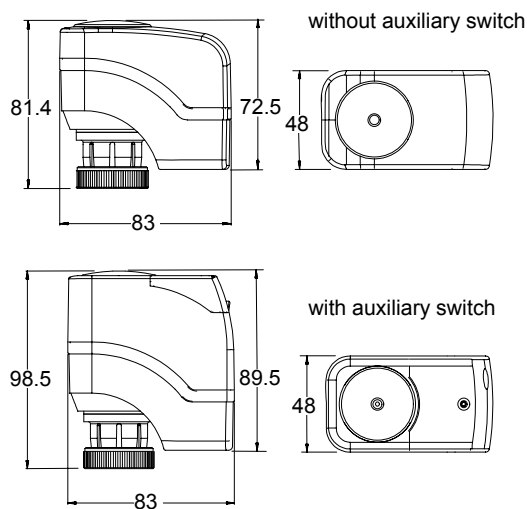

Dimensions
 baelz 373-ESI (mm)

Accessories and adapters are available on request under MP373-ESI... and ZB373-ESI...

baelz 373-ESA



DESCRIPTION

Motorized linear actuator with emergency function for baelz 475

TECHNICAL SPECIFICATIONS

Stroke max.: 7.5 mm
 Housing: plastic
 IP rating: IP 54 (installation upright)
 Thrust: 500 N
 Weight approx.: 1 kg
 Threaded connection: M32 x 1.5 mm

Manual operation (with tool only)
 with load-dependent shutdown
 in case of power failure: pushes (extends) - closed without power

Ambient temperature: 0 ... +50°C

Type	Actuating speed (s / 6 mm Stroke)	Activation/control	Supply voltage	max. power consumption approx. (VA)
373-ESA-D-05-35-230	35	3-point	230 V, 50 Hz	4 / 8
373-ESA-D-05-18-230	18	3-point	230 V, 50 Hz	4 / 8
373-ESA-D-05-30-24	slow: 45 normal: 31 fast: 17	continous	24 V, 50/60 Hz and DC	8 VA, (24 V DC: 8 W) at actuating speed "normal"

baelz 373-ESA-D-05-18-230, baelz 373-ESA-D-05-30-24

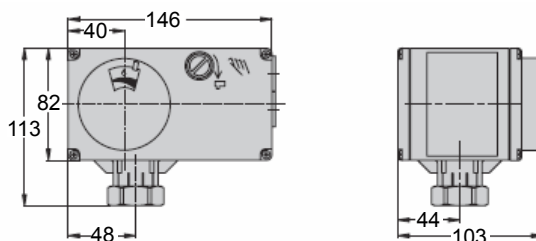

Dimensions
 baelz 373-ESA (mm)

baelz 373-ESA-D-05-35-230

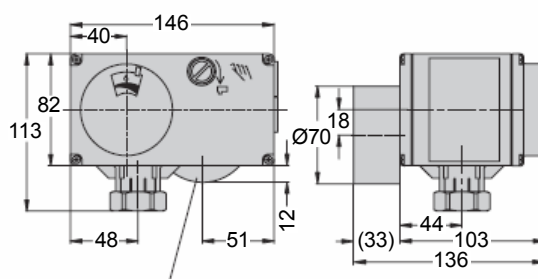



baelz 373-E07

DESCRIPTION

Motorized linear actuator for control operation For control valves up to DN125.

TECHNICAL SPECIFICATIONS

Ambient conditions:

Temperature: 0 ... +50°C

Relative humidity: 0 ... 75%

Stroke:

12, 16, 22 mm

Cover: plastic

1 cable inlet M16x1.5 (plastic)

2 locking screws for cable inlet M16x1.5 (plastic)

Manual operation

Yoke options:

Aluminum yoke for valves DN15 ... DN125

S21 - for fittings with Ø 10 mm spindle

S21-L - for fittings with Ø 16 mm spindle

Type baelz 373	Weight, approx. (kg)	Power (N)	Speed (mm/min)		Power (VA)	Supply voltage	IP rating
			50 Hz	60 Hz			
E07-20-06-S21/L	2.2	2000	6	7.2	11.7	230 V, 115 V, 24 V 50/60 Hz	IP 42*
E07-20-18-S21/L	2.2	2000	18	21.7			
E07-70-130-S21/L	2.2	700	130	156			

* - IP 65 can be ordered if manual operation is not required

Option / Extra	Description	Remarks
2EZ-V2	2 limit switches with position indicator	
Mf-FgA	Multiturn potentiometer	A= 200 Ω, 5 kΩ, 1 kΩ Please specify resistance when ordering
2EZ-V2-FgA	2 limit switches with position indicator and feedback potentiometer	
ZB373-E07-7164-230	Built-in microprocessor controller (as an accessory for E07)	including potentiometer 1-5 kΩ Supply : 24 V / 115 V / 230 V 50/60 Hz order to match actuator!
ZB373-E07-7164-115		
ZB373-E07-7164-24		
7020-230	Built-in digital positioner (as an option for E07)	Input / output signal: 0(2)...10 V / 0(4)...20mA factory setting 0...10 V Includes 5 kΩ feedback potentiometer Supply : 24 V / 115 V / 230 V 50/60 Hz
7020-115		
7020-24		
ZB373-E07-1020-24-i-M	Electric positioner, built in to E07	Option: output signal (position feedback)
MP373-E07-S21-L	Ständeraufbau für Armaturen mit Spindel-Ø 16 mm	Surcharge on top of basic price of 373-E07...S21
MP373-E07-Silf	Silicone-free version	
MP373-E07-KT9992	Mechanical travel limits	
MP373-E07-RH	Locking manual override	
MP373-E07-IP65	Ingress protection rating IP65	
MP373-E07-2RC	2 additional RC snubbers	Fitted in actuator E07..., 230 V



baelz 7164

Integrated positioners for baelz 373-E07:
 baelz 7164 - microprocessor-based controller
 baelz 7020 - digital positioner

See section: 3.4 Built-in controllers for electric actuators



baelz 7020

Dimensions
 baelz 373-E07 (mm)

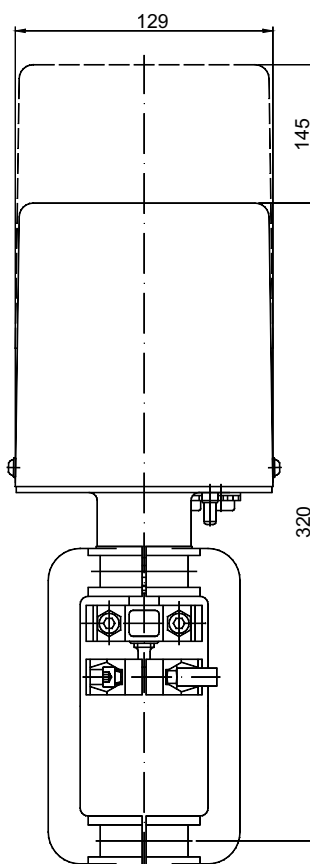

Wiring diagram, basic version

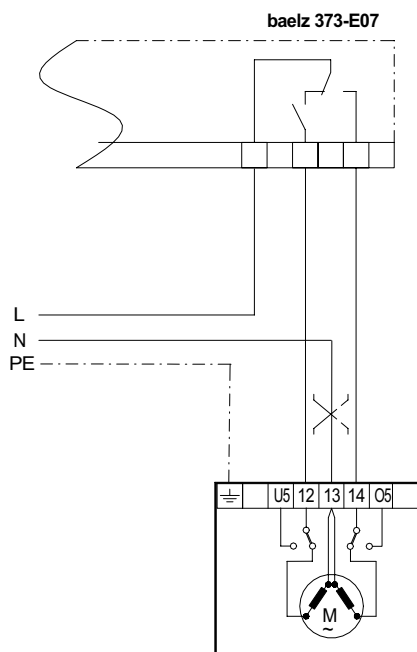

With additional limit switches

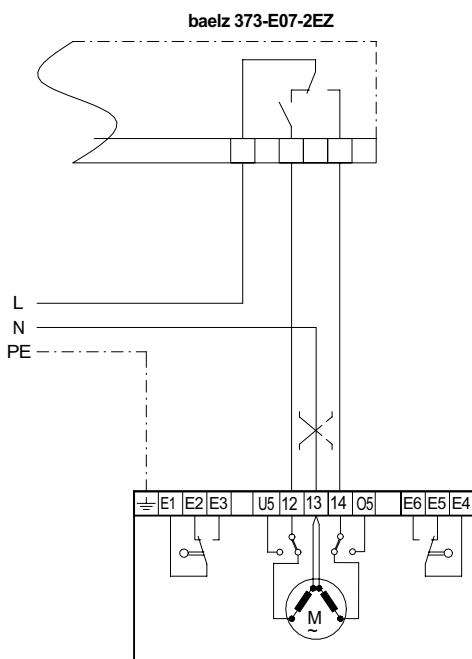

With additional limit switches and feedback potentiometer

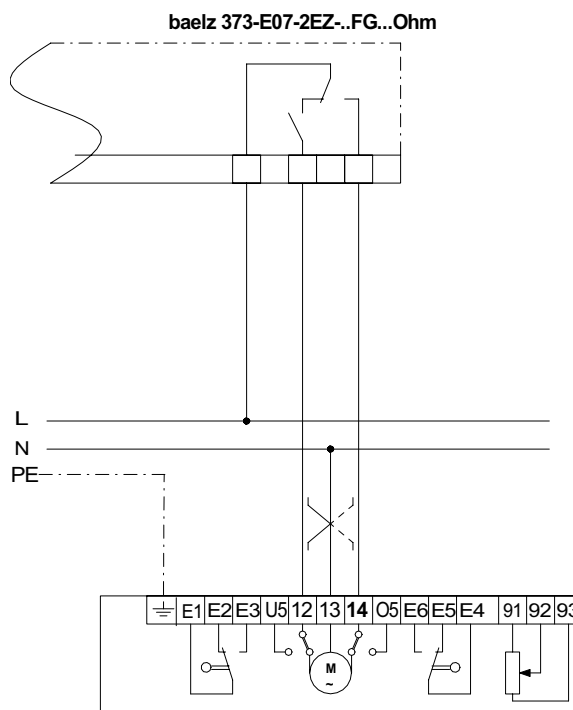

373-E07-20-18-S21-2EZ-V2-Fg

Wiring diagram, baelz 7020 digital positioner

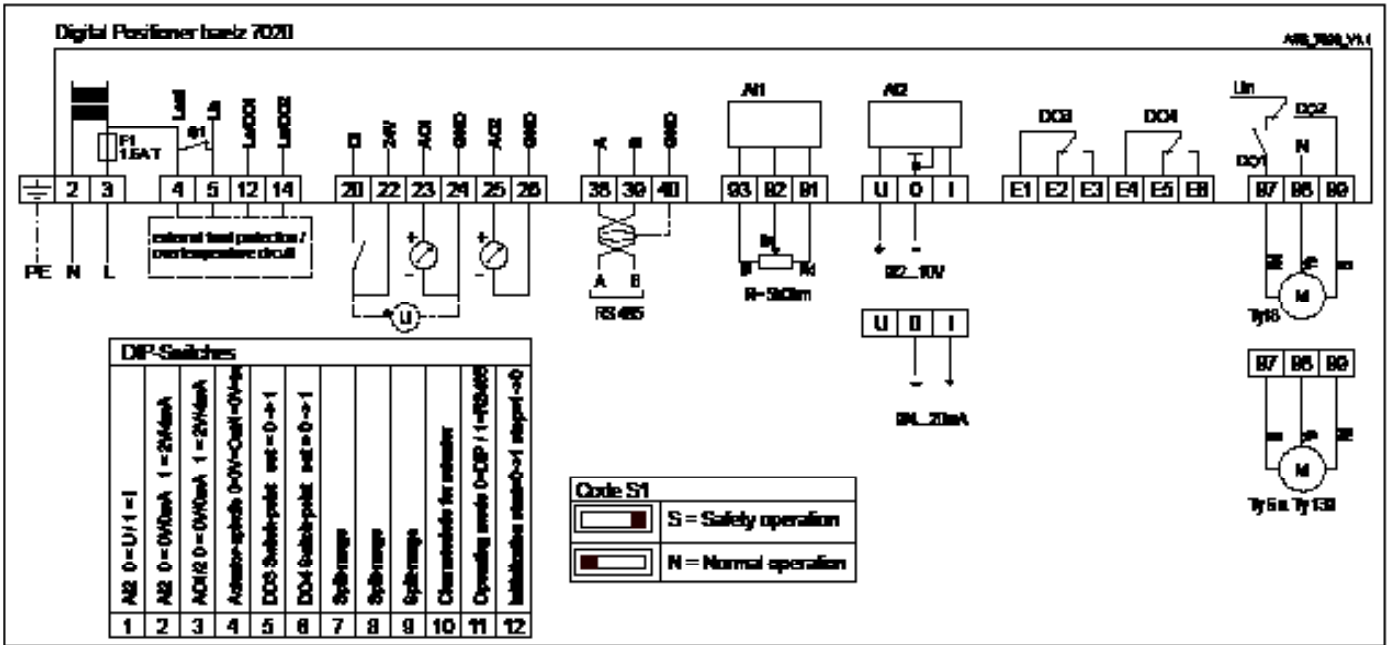

baelz 373-E07 with baelz 1020 24/50 Hz electric positioner

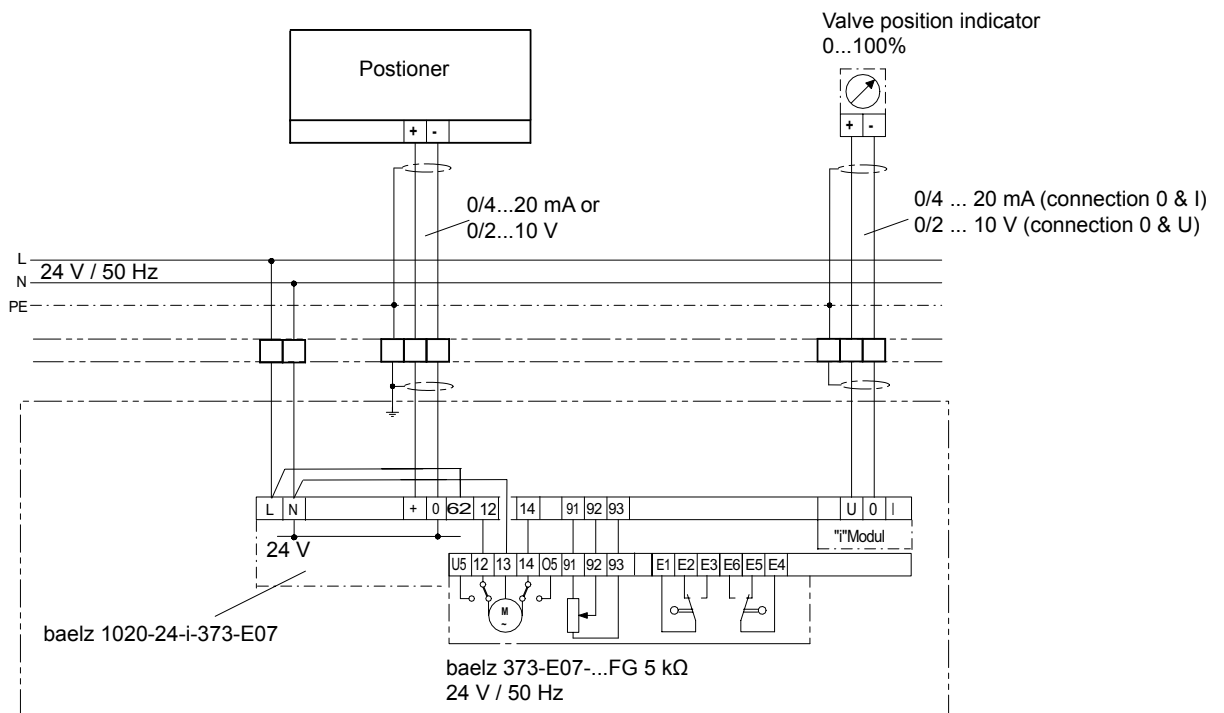



View without cover showing the baelz 7022 circuit board (230 V version)

baelz 373-E07-OSD/OSZ

DESCRIPTION

Fail-safe digital motorized linear actuator with integrated positioner baelz 7022. TÜV type-tested according to DIN EN 14597.

TECHNICAL SPECIFICATIONS

Stroke: max. 22 mm
 Cover: plastic
 IP rating: IP 42
 Power: 700 N
 Speed, adjustable: 6* / 10 / 25** / 70 / 130 mm/min
 Max. running time of safety function: 30 s
 Weight: approx. 3 kg
 1 cable inlet M16x1.5 (plastic), 2x M16x1.5 blind plugs
 Manual adjustment with internal push buttons or using interface
 Electronic power-dependent limit switch
 Self-initializing

Ambient conditions:
 Temperature: 0 ... +50 °C
 Relative humidity: < 90% RH non-condensing

Options aluminium yoke:
 S21 - for fittings with Ø 10 mm spindle
 S21-L - for fittings with Ø 16 mm spindle

* only in Modbus mode
 ** factory setting

Type baelz 373-	Safety function	Yoke	Supply voltage	Power
373-E07-OSD-07-130-S21-24V	fail-safe extends spindle (OSD: ohne Strom drückend)	S21	24 V DC, 24 V AC, 50/60 Hz	max. power consumption = 30 VA
373-E07-OSD-07-130-S21L-24V		S21-L		
373-E07-OSD-07-130-S21-230V		S21	100...240 V AC, 50/60 Hz	
373-E07-OSD-07-130-S21L-230V		S21-L		
373-E07-OSZ-07-130-S21-24V	fail-safe retracts spindle (OSZ: ohne Strom ziehend)	S21	24 V DC, 24 V AC, 50/60 Hz	
373-E07-OSZ-07-130-S21L-24V		S21-L		
373-E07-OSZ-07-130-S21-230V		S21	100...240 V AC, 50/60 Hz	
373-E07-OSZ-07-130-S21L-230V		S21-L		

Option / Extra	Description	Remarks
MP373-E07-OSX-Fg5k	potentiometer, 5 kΩ	built into the actuator ex works
ZB373-E07-OSX-NT100-240V	wide-range power supply module for 100...240 V AC	including fixing material, not including fitting
ZB373-E07-OSX-Fg5k	potentiometer, 5 kΩ	including fixing material, not including fitting

Technical specifications of baelz 7022 positioner	
2 output signals	output 1: 0...10 V and output 2: 0...20mA or output 1: 2...10 V and output 2: 4...20mA factory setting: 0...10 V and 0...20mA
Input signal	0/2...10 V or 0/4...20 mA measurement accuracy 0.1 %
Digital outputs	2 auxiliary changeover switches max. 250 V AC / 6 A
Digital inputs	2x 24-240 V AC 50...60 Hz +10/-15% / 24-240 V DC +10/-15% (AUF/ZU), 1x 24 V DC +10/-15%
Connection	PUSH IN spring connections
Interface	RS485 Modbus RTU
Operation	15 DIP switches / advanced operation using free software Winbas Tools Par / Modbus mode

Direction of action baelz 373-E07-OSD/OSZ with valve or ejector

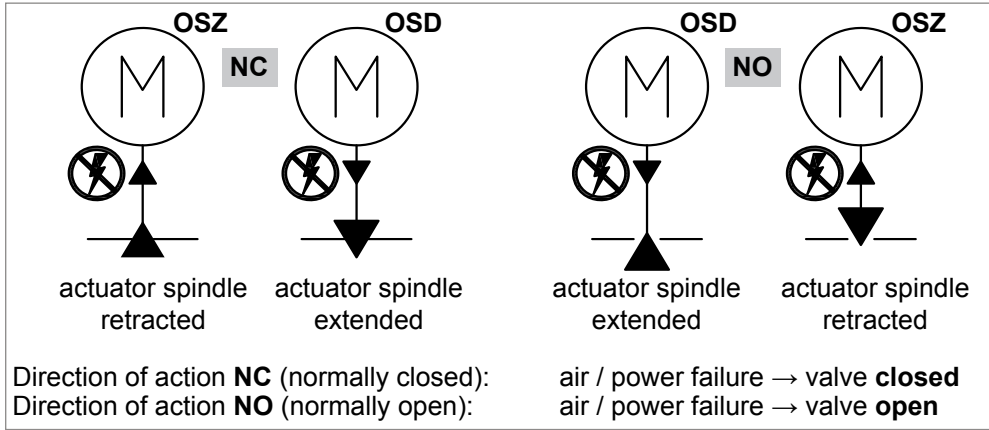

OSD = fail-safe extends actuator spindle
 OSZ = fail-safe retracts actuator spindle

Dimensions of baelz 373-E07-OSD/OSZ with yoke S21

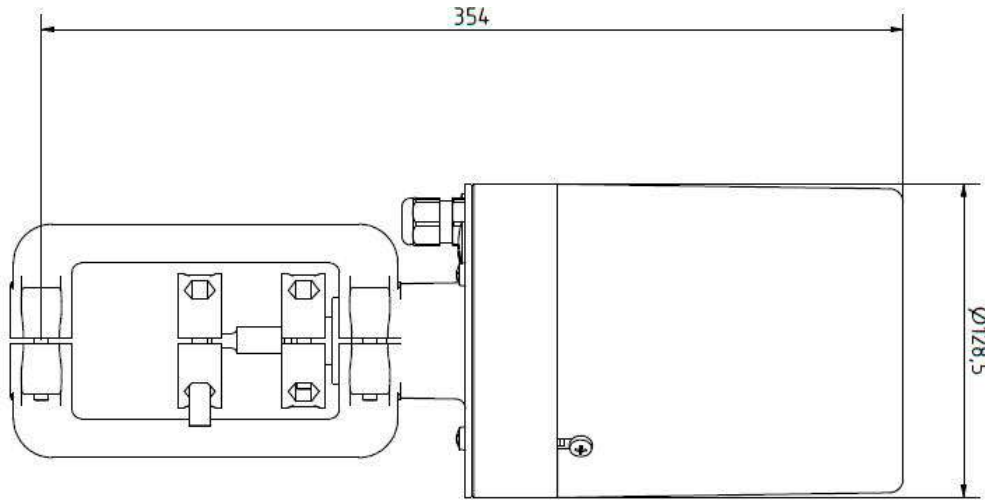

Wiring diagram of baelz 7022 digital positioner

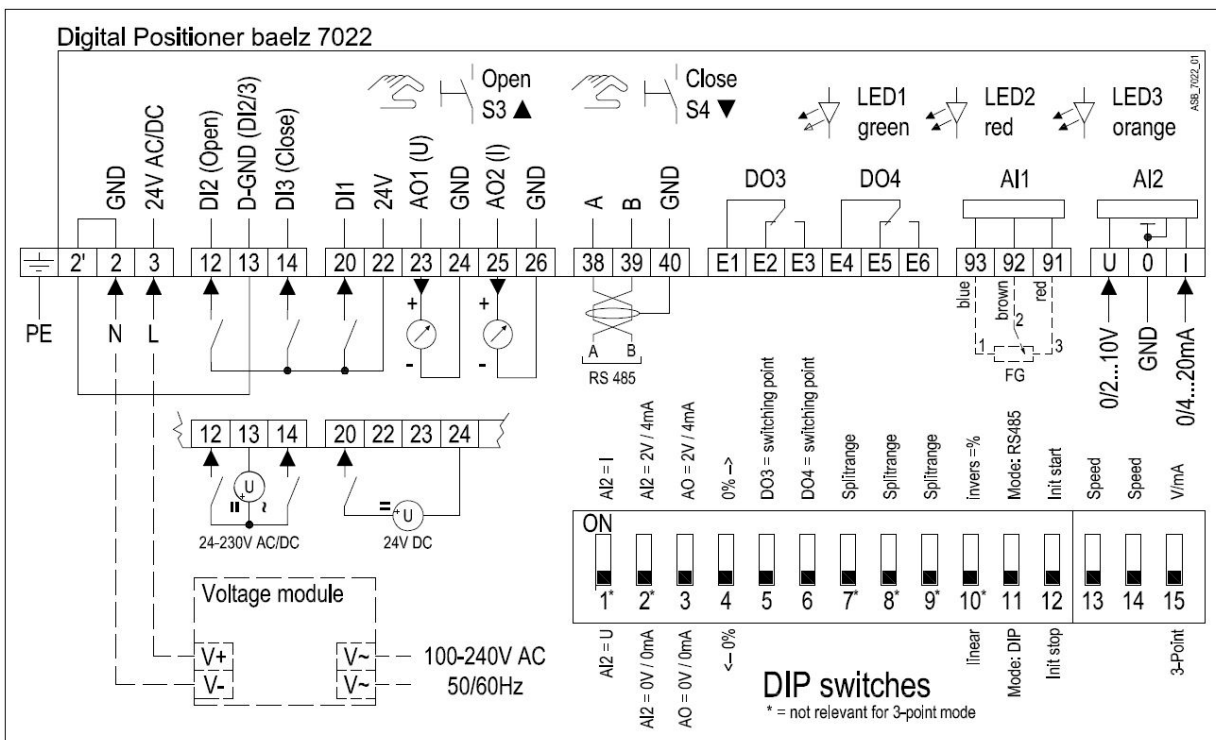

Baelz-Katalog_11_EN_MJ_0221



baelz 373-E45

DESCRIPTION

Electric linear actuator with load-dependent limit switches.

TECHNICAL SPECIFICATIONS

Actuator control: 3 point
 Stroke: 12, 16, 22, 40, 44 mm
 Electrical connection: 3 x M20x1.5
 Cover: plastic, yellow
 Manual operation: crank handle
 Actuator: Synchronous actuator

Ambient conditions:
 Temperature: 0 ... +50°C Relative humidity: 0 ... 75%

Yoke options:
 Aluminum yoke for DN15 ... DN125
 S21 - for fittings with Ø 10 mm spindle
 S21-L - for fittings with Ø 16 mm spindle

Galvanized steel yoke for DN150
 S41 - for fittings without cooling tube
 S41C - for fittings with cooling tube

Type baelz 373	Weight, approx.	Power (N)	Speed (mm/min)	Power (VA)	Supply voltage	IP rating
	(kg)					
E45-40-15-S21/L	8	4000	15	11	230 V, 115 V, 24 V 50/60 Hz	IP65
E45-40-15-S41C	15 / 18					

Options / Extras		
Option	Description	Remarks
2EZ-FgA	2 additional position switches with potentiometer	A= 5 kΩ or 1 kΩ Specify resistance when ordering
MP373-E45-Hzg-230VAC	Heating resistor for electric actuator 230V 50 / 60Hz	Power 15W For ambient temperatures -20°C ... + 50°C
MP373-E45-Hzg-115VAC	Heating resistor for electric actuator 115V 50 / 60Hz	
MP373-E45-Hzg-24VAC	Heating resistor for electric actuator 24V 50 / 60Hz	
MP373-E45-Hzg-OS	Outdoor model: with 1.4571 stainless steel cover with internal insulation and actuator heating.	Power 15W Outdoor model for min. temperature - 40°C
7020A-230	Controller for electric actuator 230V 50 / 60Hz (115 V / 24 V optional)	2 output signals: output 1: 0...10 V and output 2: 0...20mA (factory setting) or output 1: 2...10 V and output 2: 4...20mA please specify when ordering incl. potentiometer 5 kΩ
MP373-E45-PDB100	Extra: Profibus module DP	for actuator control; not suitable for retrofitting

Further accessories and electronic spares are available on request under MP373-E45... and ZB373-E45...

Integrated positioner for baelz 373-E45:

baelz 7020A - digital positioner

See section: 3.4 Built-in controllers for electric actuators



baelz 7020A

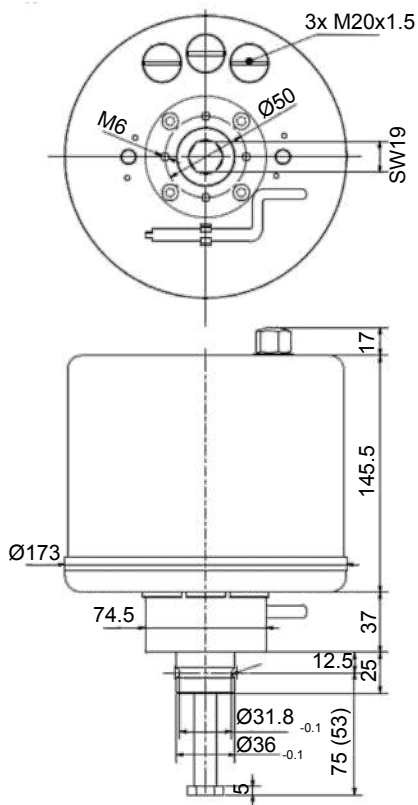

Dimensions
baelz 373-E45
with yoke S41 /
S41-C (mm)

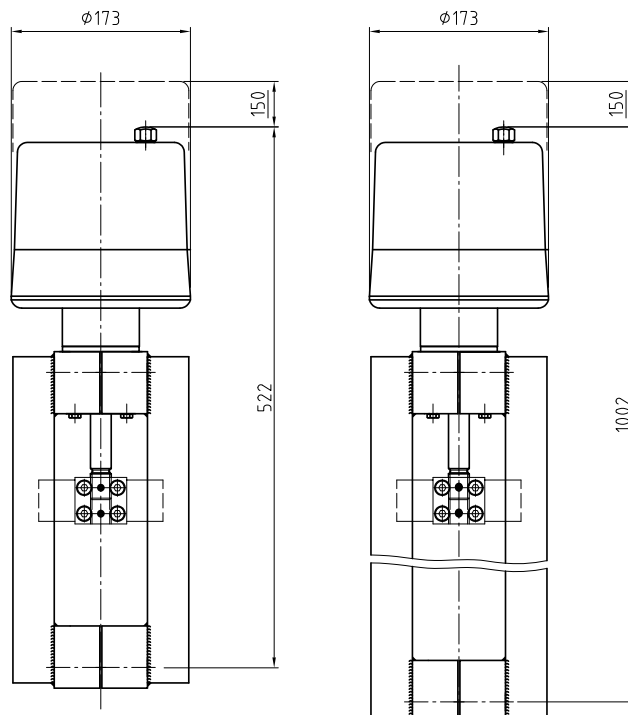

Dimensions
baelz 373-E45
with yoke S21
(mm)

Wiring diagram for baelz 373-E45 electric actuator - Basic version

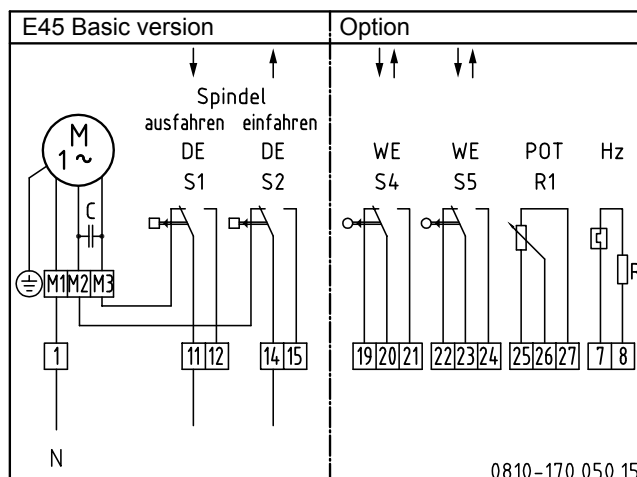



baelz 373-E65

DESCRIPTION

Motorized linear actuator with emergency stop function and load-dependent limit switches. Available with fail-safe open or closed.

TECHNICAL SPECIFICATIONS

Input signal:	0-10 V or 4-20 mA, 2 or 3-point selectable
Output signal:	0-10 V, burden >2,5 kΩ
Power consumption:	18 VA
Stroke:	40 mm, self-adapting
Set-up:	automatic initialization
Electrical connection:	2 x M20 x 1.5, 1 x M16 x 1.5
Housing:	yellow plastic, silicone-free
Manual operation:	push-button (E65-11) / mechanical (E65-20)
Motor:	brushless DC motor
Ambient conditions:	Temp: -10 ... +55°C Rel. humidity: 0 ... 95%
TÜV approved:	1100 N models TÜV type tested

Aluminum yoke, coupling and fixing screws:
 S21 (standard) - fittings with Ø 10 mm spindle
 S21-L - fittings with Ø 16 mm spindle

Type baelz 373	Weight, approx. (kg)	Power (N)	Actuating speed (mm/min)	Supply voltage	Position feedback	in case of power failure	IP rating
373-E65-D-11-30	5.6	1100	10, 15, 30 adjustable, please specify when ordering. Default: 10	24 V AC 50/60 Hz 24 V DC	10-0 V	extends	IP66 (installation upright)
373-E65-Z-11-30					0-10 V	retracts	
373-E65-D-20-30		2000			10-0 V	extends	
373-E65-Z-20-30					0-10 V	retracts	

Options

Option	Description	Remarks
2EZ	2 additional travel-dependent limit switches	12...250 V AC, adjustable
Split-Range	Split-range module for setting up sequences	$U_0 = 0...8 V$, $\Delta U = 3...10 V$
110 V	Power module 110 V AC	plug-in
230 V	Power module 230 V AC	plug-in
MP373-E65-OS	Outdoor version of 373-E65	for temperatures of -10...+55 °C

Please note! Direction of control action depends upon both the actuator and control valve selected! (See illustration, next page)

Valve	State of valve with spindle extended	Actuator	Fail-safe function of actuator	Function Valve + Actuator
340-2,...,342-2,...,347-2,..., 353, 354, 365, 367	open	E65-D-11-30... E65-D-20-30...	extending	FSO (fail-safe open)
344, 356, 358, 359, 360, 471, 480, 585, 590, 591	closed			FSC (fail-safe closed)
340-2,...,342-2,...,347-2,..., 353, 354, 365, 367	open	E65-Z-11-30... E65-Z-20-30...	retracting	FSC (fail-safe closed)
344, 356, 358, 359, 360, 471, 480, 585, 590, 591	closed			FSO (fail-safe open)

Output signal can be converted using a buffer amplifier. (Not included in price. Fitting in control cabinet.)

for 373-E65 fail-safe extending (output signal 373-E65 inverted)		for 373-E65 fail-safe retracting	
Baelz type: 6260-8.1invertiert-7.1	0...10 V and 0...20 mA	Baelz type: 6260-8.1-7.1	0...10 V and 0...20 mA
Baelz type: 6260-8.1invertiert-7.2	2...10 V and 4...20 mA	Baelz type: 6260-8.1-7.2	2...10 V and 4...20 mA

NO (normally closed) / FSC (fail-safe closed)

NO (normally open) / FSO (fail-safe open)

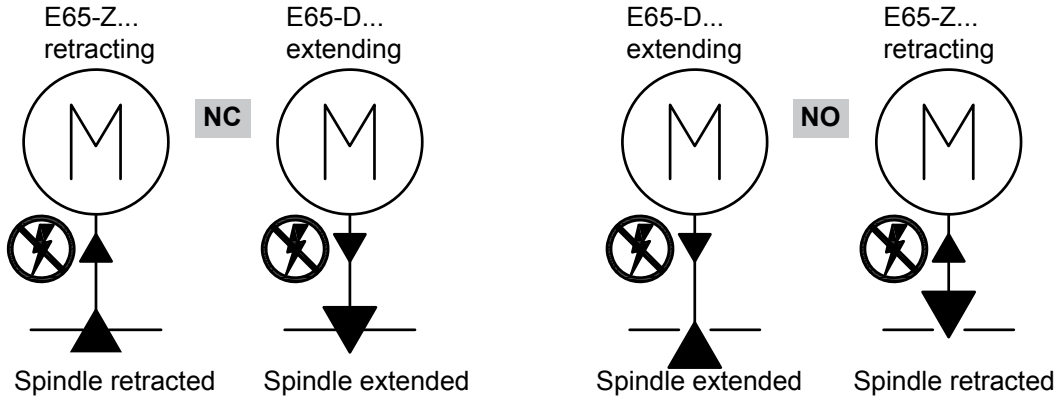

Direction of action baelz 373-E65 with control valve

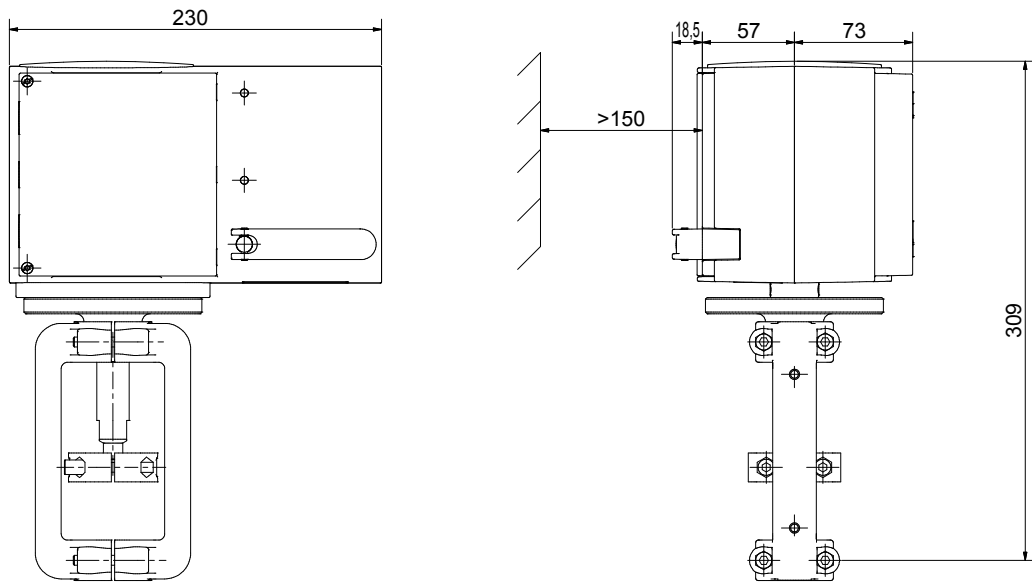

baelz 373-E65 dimensions

230V

110V

24V

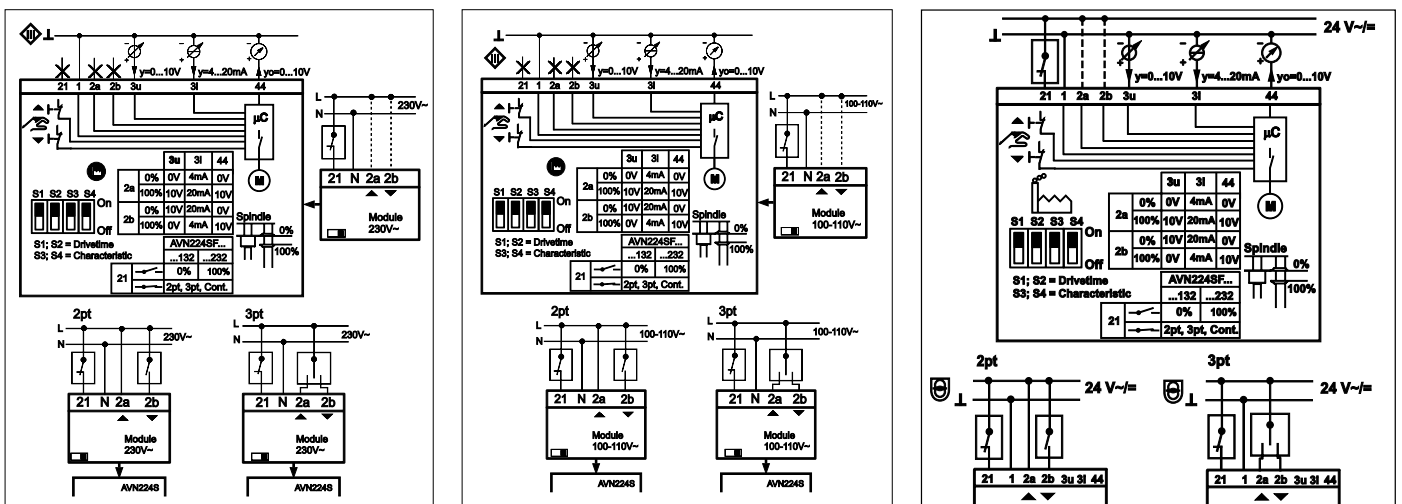

baelz 373-E65 wiring diagrams



baelz 373-E66

DESCRIPTION

Electric linear actuator with load-dependent limit switches.
For control valves up to DN150-DN300.

TECHNICAL SPECIFICATIONS

Actuator control: 3 point
 Stroke: 12 - 66 mm
 Electrical connection: 4 x M16x1.5
 Cover: metal, yellow
 Manual operation: handwheel
 Actuator: Synchronous actuator

Ambient conditions:
 Temperature: 10 ... +50°C; relative humidity: 0 ... 75%

Yoke options:
 S41 - for fittings with Ø 22 mm spindle without cooling tube
 S41C - for fittings with Ø 22 mm spindle with cooling tube
 S23 - for fittings with Ø 10 mm spindle (also available in stainless steel)
 S23L - for fittings with Ø 16 mm spindle (also available in stainless steel)

Type baelz	Weight, approx.	Power	Actuating speed	Power	Supply voltage	IP rating
	(kg)	(N)	(mm/min)	(VA)		
373-E66-80-25	13	8000	25	34	230 V, 115 V, 24 V 50/60 Hz	IP65
373-E66-150-22		15000	22			

Options / Extras		
Option	Description	Remarks
Hgz-230	Heating resistor for electric actuator 230V 50 / 60Hz	Power 15W For ambient temperatures -20°C ... + 50°C
Hgz-115	Heating resistor for electric actuator 115V 50 / 60Hz	
Hgz-24	Heating resistor for electric actuator 24V 50 / 60Hz	
7020A-230	Controller for electric actuator 230V 50 / 60Hz (115 V / 24 V optional)	2 output signals: output 1: 0...10 V and output 2: 0...20mA (factory setting) or output 1: 2...10 V and output 2: 4...20mA please specify when ordering incl. potentiometer 5 kΩ
MP373-E66-Hzg-OS	Outdoor version of 373-E66	for temperatures as low as -40 °C

Further accessories and electronic spares are available on request under MP373-E66... and ZB373-E66...

Integrated positioner for baelz 373-E66:

baelz 7020A - digital positioner

See section: 3.4 Built-in controllers for electric actuators



baelz 7020A

Without options

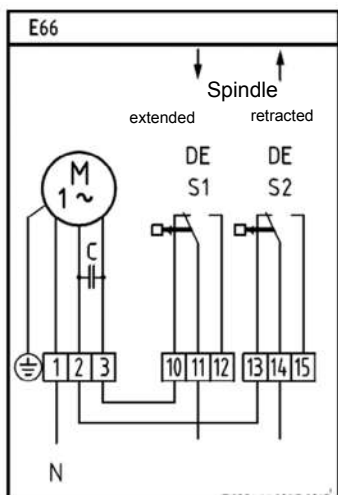

Option set 2

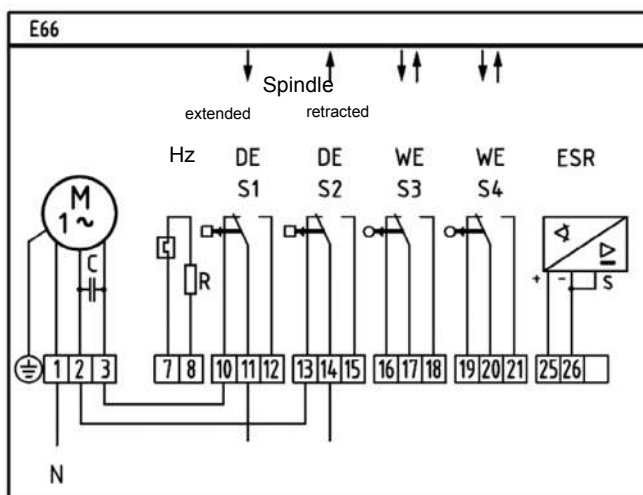

Option set 1

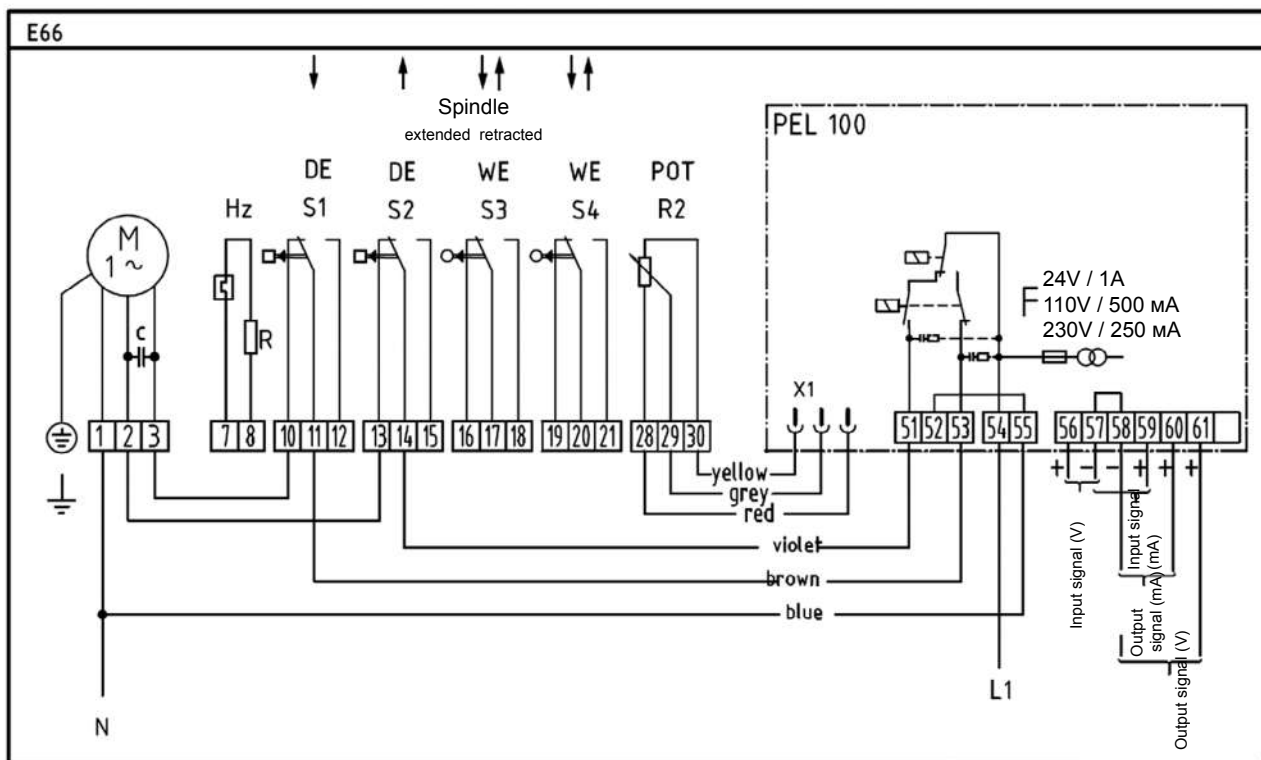

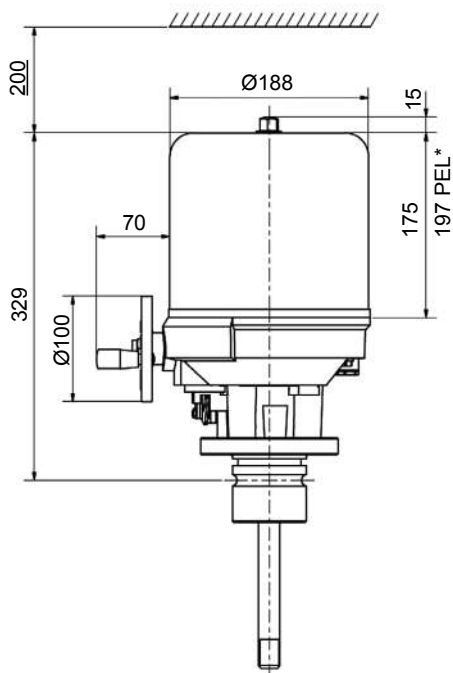
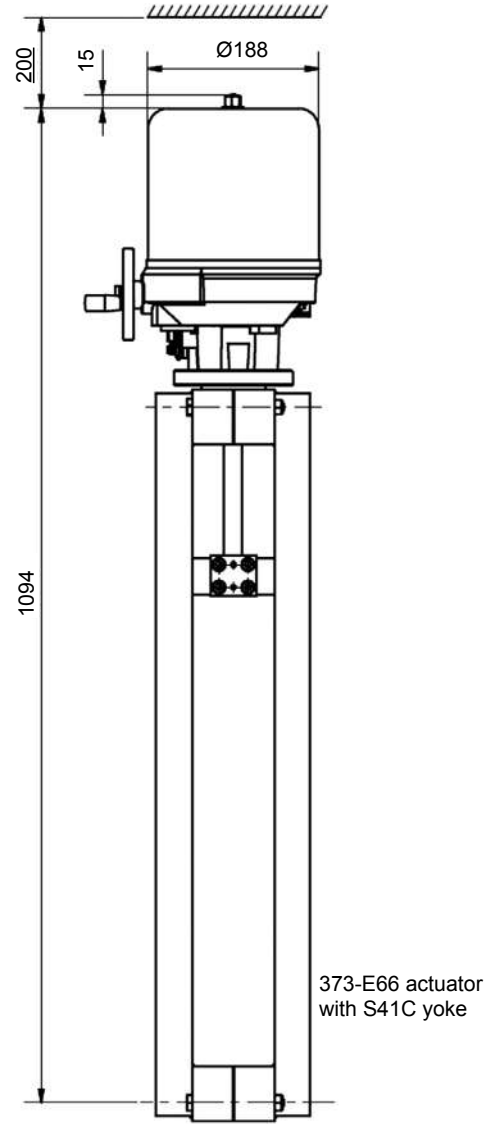
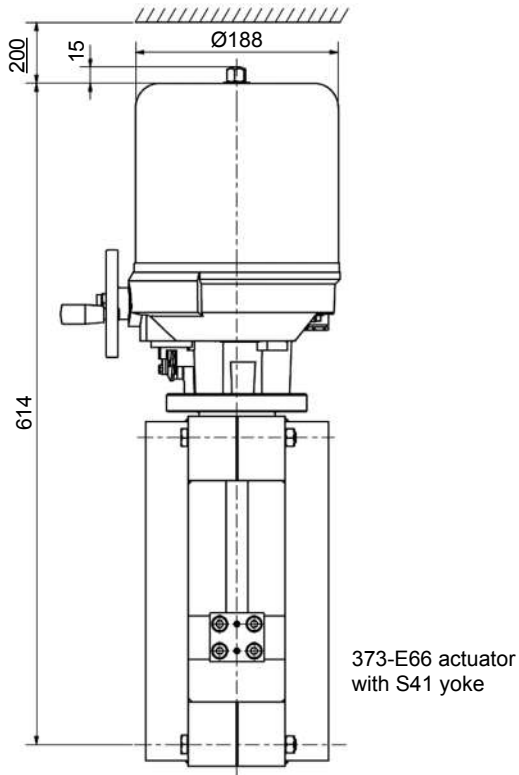

* PEL = with positioning electronics

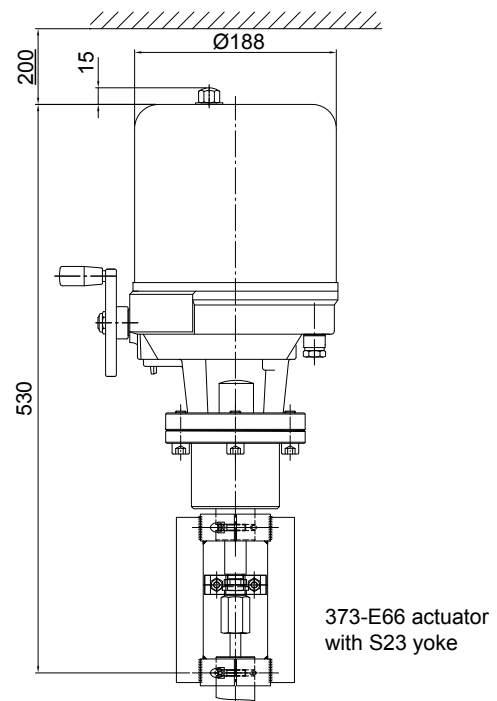



baelz 375-E42

DESCRIPTION

Rotary actuator with load-dependent and travel-dependent limit switches.

TECHNICAL SPECIFICATIONS

Actuator control: 3 point
 Angle of rotation: 90°
 Electrical connection: 3 x M20x1.5
 Cover: plastic, gray
 Manual operation: handwheel
 Position indicator: integrated in cover
 Actuator: Synchronous actuator
 Mechanical connection: according to ISO 5211
 square socket connection SW17
 including adaptor SW17/ SW14

Ambient conditions:
 Temperature: -10 ... +50°C
 Relative humidity: 0 ... 75%

Type baelz	Weight, approx.	Torque	Actuating speed	Power	Supply voltage	IP rating
	(kg)	(Nm)	(s/90°)	(VA)		
375-E42-150Nm-60s-230V	7.5	150	60	65	230 V, 50/60 Hz	IP65

* Actuators with supply voltage 115 V and 24 V available upon request

Options		
Option	Description	Remarks
2EZ	2 additional limit switches	
Fg5k	Potentiometer	5 kΩ
7020A-230V	Controller for electric actuator 230V 50 / 60Hz (115 V / 24 V optional)	2 output signals: output 1: 0...10 V and output 2: 0...20mA (factory setting) or output 1: 2...10 V and output 2: 4...20mA please specify when ordering incl. potentiometer 5 kΩ Output signal = input signal

Further accessories and electronic spares are available on request under MP375-E42... and ZB375-E42...

Integrated positioner for baelz 375-E42

baelz 7020A - digital positioner

See section: 3.4 Built-in controllers for electric actuators



baelz 7020A

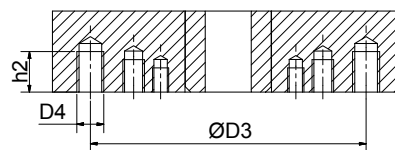
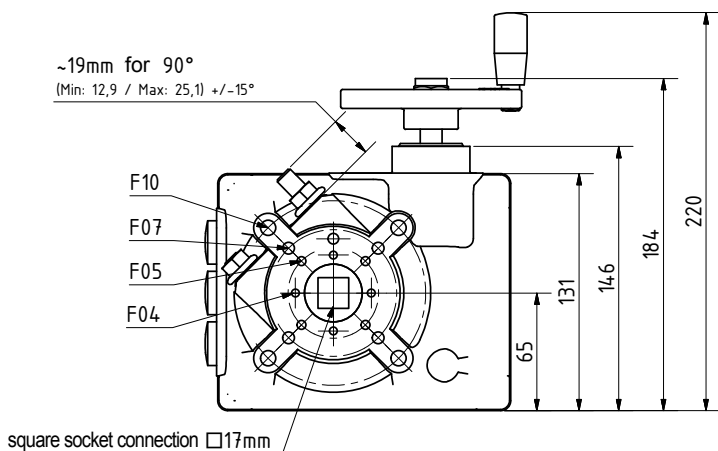

	ØD3 (mm)	D4	h2 (mm)	Mmax (Nm)
F 04	42	M5	8	63
F 05	50	M6	9	125
F 07	70	M8	12	250
F 10	102	M10	15	500

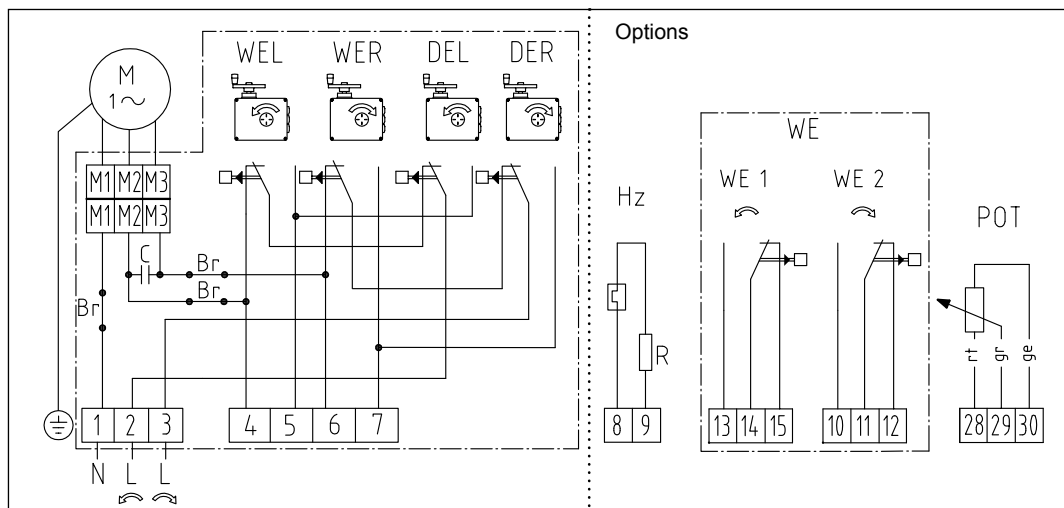
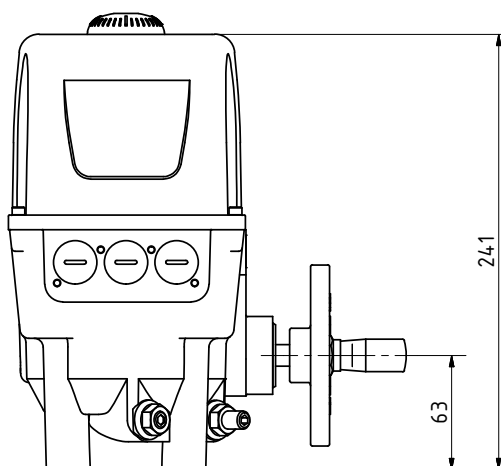
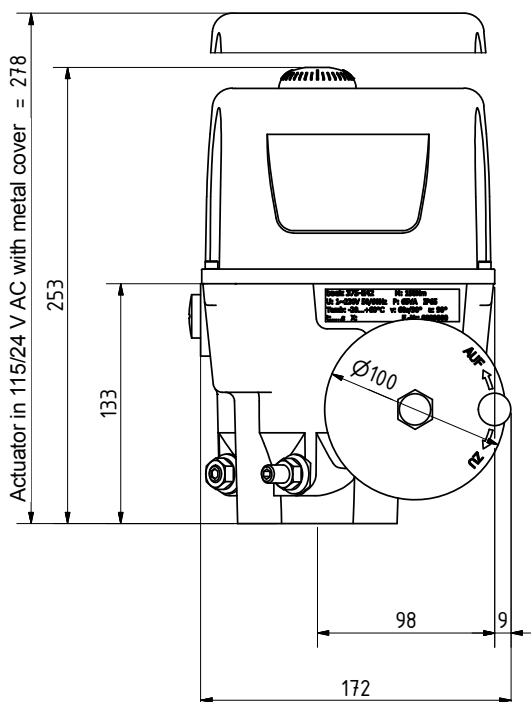



baelz 7164

BUILT-IN MICROPROCESSOR CONTROLLER

Installed in baelz 373-E07 motorized linear actuator
 Constant setpoint or heating curve with 5 plotting points
 Analog inputs PT100 (-40 ... + 120°C), NTC, O / 4 ... 20 mA, 0/2 ... 10 V,
 teletransmitter 1-5 kΩ

ADVANTAGES AT A GLANCE

- Reduced fitting costs due to elimination of signal cabling between actuator and controller
- Free WTP parameterisation software (Modbus RTU)
- Overall installation costs and effort are minimized
- Space saving, as the controller hardware sits in the actuator
- Variable, outside temperature-controlled characteristic

baelz 7164 positioner technical specifications

Analog inputs	4	Interface	RS485 Modbus RTU with interface converter order no. 5280-051/ connector for manual control unit
Analog outputs	2x (0/2 ... 10 V)	Power supply	230 V. 50/60 Hz; 115 V. 50/60 Hz; 24 V. 50/60 Hz;
Digital outputs	2x relays	Weight	approx. 0.2 kg
Digital inputs	2	Ambient temperature	0 ... 50 °C
Connection	Spring clips	Ambient humidity	5 ... 90% (non-condensing)
Precision	0.3 % of upper range value		

baelz 7164 wiring diagram

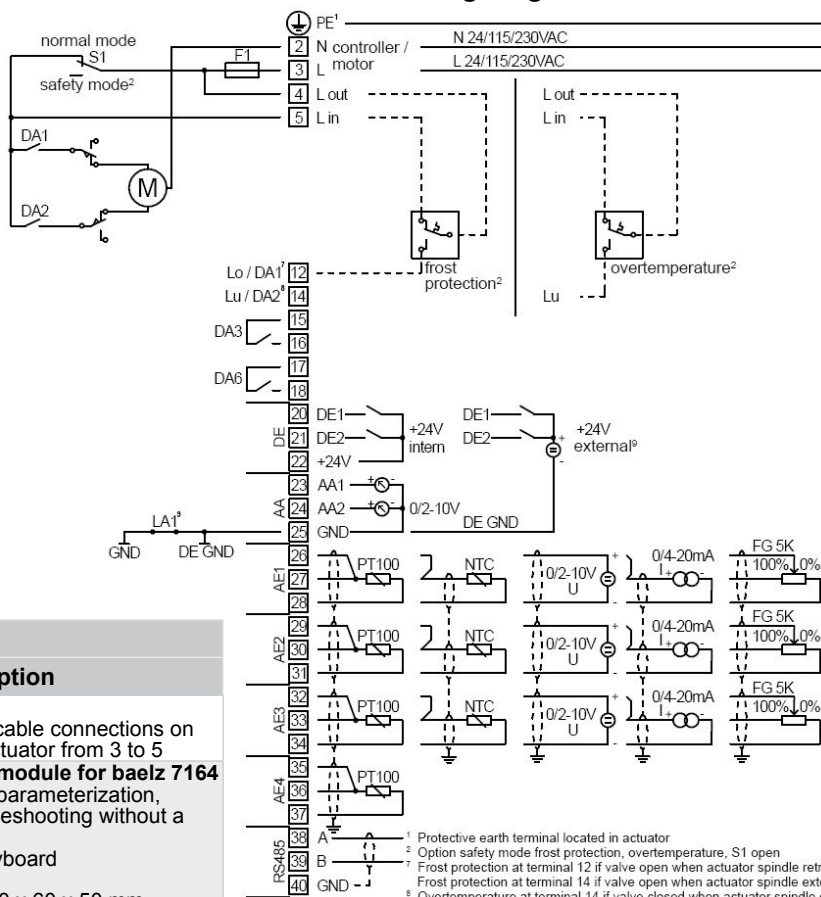

Options baelz 7164

Option	Description
ZB373-E07-7164-1385	5/3 cable gland adapter increases the number of cable connections on the housing of the E07 actuator from 3 to 5
ZB373-E07-7164-1381	Plug-in manual control module for baelz 7164 for on-site operation and parameterization, commissioning and troubleshooting without a RS485 bus controller. With LCD display and keyboard 1 m cable with plug Dimensions: (HxWxD) 160 x 60 x 50 mm Weight, approx. : 0.2 kg



baelz 7020

DIGITAL POSITIONER

Installed in baelz 373-E07 motorized linear actuator

Setting with DIP switches and LED or Modbus.

ADVANTAGES AT A GLANCE

- Self-adaptation (controller, hysteresis, valve runtime)
- Detection and suppression of interference signals
- Error detection and alarm functions - e.g. fail-safe position
- Free WTP parameterisation software (Modbus RTU)
- Comfortable operation and optimized actuator installation
- Variable valve characteristics with high resolution

baelz 7020 positioner technical specifications

2 output signals	output 1: 0...10 V and output 2: 0...20mA or output 1: 2...10 V and output 2: 4...20mA factory setting: 0...10 V und 0...20mA	Interface	RS485 Modbus RTU with interface converter order no. 5280-051
Input signal	0/2...10 V or 0/4...20 mA Precision 0.1 %	Operation	12 DIP switch / extended operation with free software Winbas Tools Par / Modbus operation
Digital outputs	2 potential-free additional limit switches adjustable, max. 250 V, 4 A, min. contact load digital outputs: 10 V / 100 mA	Power supply	230 V. 50/60 Hz; option 115 V. 50/60 Hz; 24 V. 50/60 Hz;
Digital input	1 adjustable (e.g. summer/winter switchover), I _{max} 5 mA, low = 0...5 V DC, high = 9...38 V DC, R _e = 5 kΩ	Fuse	internal 1.6 A/T
DE supply voltage	24 V DC. I _{max} = 5 mA	Power consumption	approx. 5 VA
Connection	PUSH IN spring clamps	Weight	approx. 0.2 kg
		Ambient temperature	0 ... 50 °C
		Ambient humidity	5 ... 90% (non-condensing)

The actuator must be equipped with a 5 kΩ feedback potentiometer

baelz 7020 wiring diagram

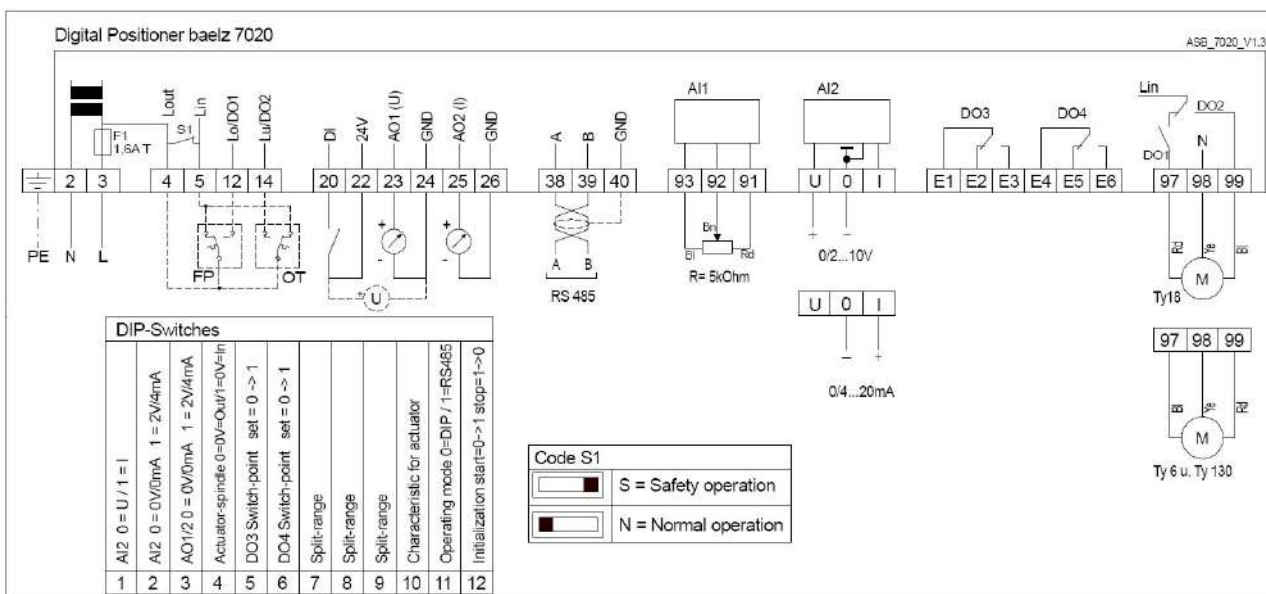

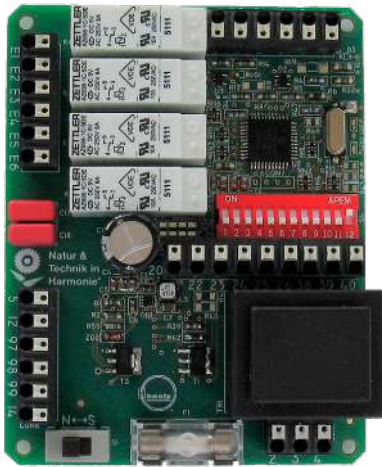

baelz 7020A

DIGITAL POSITIONER

Installed in motorized linear actuator baelz 373-E45 / baelz 373-E66
 Installed in rotary motorized actuator baelz 375-E42
 Setting with DIP switches and LED or Modbus.

ADVANTAGES AT A GLANCE

- Self-adaptation (controller, hysteresis, valve runtime)
- Detection and suppression of interference signals
- Error detection and alarm functions - e.g. Eg fail-safe position
- Free WTP parameterisation software (Modbus RTU)
- Comfortable operation and optimized actuator installation
- Variable valve characteristics with high resolution

baelz 7020A positioner technical specifications

2 output signals	output 1: 0...10 V and output 2: 0...20mA or output 1: 2...10 V and output 2: 4...20mA factory setting: 0...10 V und 0...20mA	Interface	RS485 Modbus RTU with interface converter order no. 5280-051
Input signal	0/2...10 V or 0/4...20 mA Precision 0.1 %	Operation	12 DIP switch / extended operation with free software Winbas Tools Par / Modbus operation
Digital outputs	2 potential-free additional limit switches adjustable, max. 250 V, 4 A, min. contact load digital outputs: 10 V / 100 mA	Power supply	230 V. 50/60 Hz; option 115 V. 50/60 Hz; 24 V. 50/60 Hz;
Digital input	1 adjustable (e.g. summer/winter switchover), I _{max} 5 mA, low = 0...5 V DC, high = 9...38 V DC, R _e = 5 kΩ	Fuse	internal 1.6 A/T
DE supply voltage	24 V DC, I _{max} = 5 mA	Power consumption	approx. 5 VA
Connection	PUSH IN spring clamps	Weight	approx. 0.2 kg
		Ambient temperature	0...50 °C
		Ambient humidity	5...90% (non-condensing)

Positioner includes built-in 5 kΩ feedback potentiometer

baelz 7020A wiring diagram - example with baelz 373-E45 linear motorized actuator

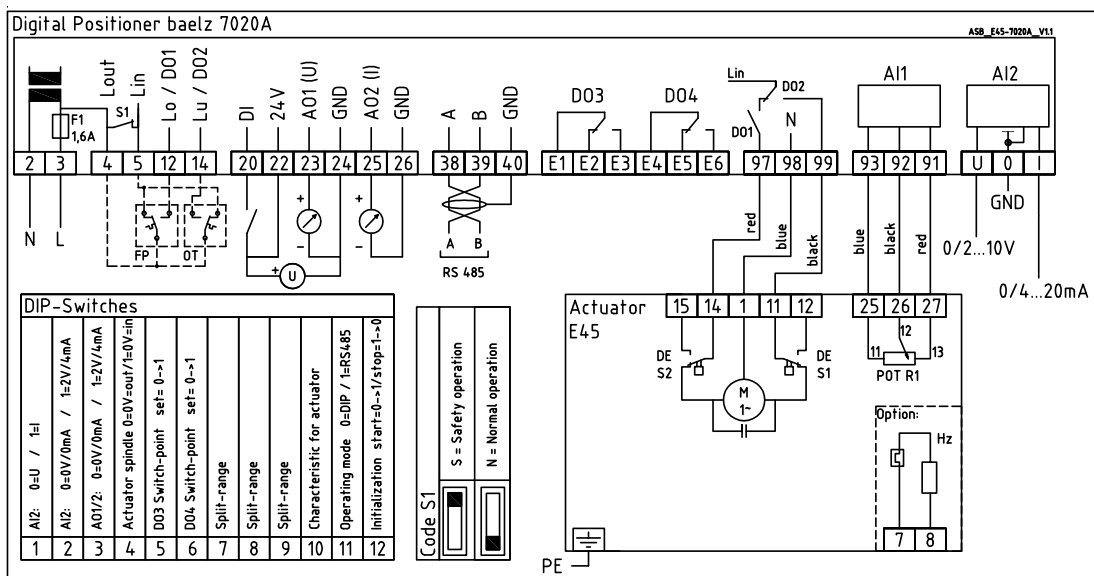

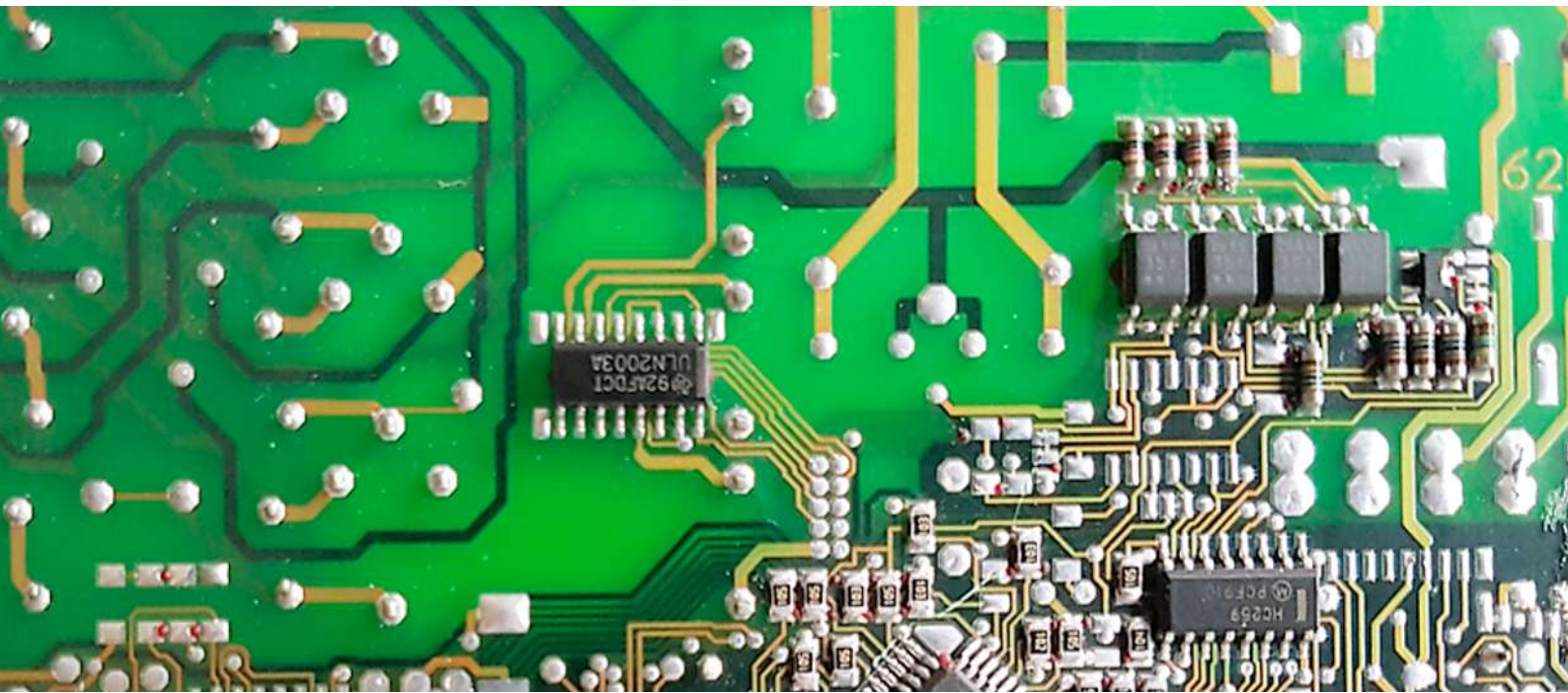

4.1 Controllers, control technology and ancillary equipment - product overview

page 133

baelz 5192



HMI device with touchscreen

- flexible operating device
- also for the operation of several devices
- multiple connection options
- 4.3" or 7.0" screen
- as master over Modbus RTU
- as a client via Modbus TCP
- various visualization options
- remotely controllable

page 135

baelz 6164B



Microprocessor compact controller

- for heating systems
- regulates flow temperature depending on outside temperature
- RS-485 Modbus RTU interface
- various additional functions
- as three-point step/three-point/two-point or continuous controller
- with analog output 0/2 ... 10 V

page 137

baelz 6200



Microprocessor controller

- for major BACS projects
- expandable, modular system
- several software options
- up to 16 control circuits
- integrated PLC control
- simple operation
- several installation options

page 142

baelz 6490 / 6590



PID 3-point step controller

- Industrial controller with special PID step-controller algorithm
- compact and reliable
- simple operation
- self-adaptation of the control parameters
- Manual/automatic switchover
- two-point/three-point selectable
- LED displays for setpoint and actual value

page 145

baelz 6496 / 6596



PID continuous controller

- P/PD/PI/PID control behavior with continuous control signal
- compact and reliable
- simple operation
- self-adaptation of the control parameters
- Manual/automatic switchover
- LED displays for setpoint and actual value

page 148

baelz 6497 / 6597



PID 3-point step controller

- PI/PID control response with three-point output
- compact and reliable
- simple operation
- self-adaptation of the control parameters
- Manual/automatic switchover
- two-point/three-point selectable
- LED displays for setpoint and actual value

page 150 - page 162

Ancillary equipment

Baelz Type	device	page	Baelz Type	device	page
5195-SWI-5	5-port Ethernet switch	150	6205-B	Transformer	158
5277-2	RSS 422/485 repeater	150	6208/2-1,0A	Power supply	158
5280...	Interface converter	150	6208/3	Switch-mode power supply	158
5280-TS	Interface converter	150	6226-B	Digital display	159
5280-MX-UPort	Interface converter	151	1046	Safety Zener barriers	159
5279-BAC-5-RS4-...	BACnet protocol converter	151	1049-T	Isolating transformer	160
5279-DP	Protocol converter	152	6260	Isolation amplifiers	160
5279-PNET	Protocol converter	152	6261	Measuring amplifier	161
5279-BAC-2-TCP	BACnet protocol converter	153	3502	Aluminum plate	161
5279-BAC-2-RS4	BACnet protocol converter	153	3503	Aluminum plate	161
5279-NB2	Remote maintenance module	155	3540-1	Aluminum adapter plate	161
452-N-1	Control unit	156	3505	Transparent door closable	162
455	Empty housing	157	3506-C	Adapter	162
455-2	Empty housing	157	3508-3514	Aluminum adapter plate	162
455-3	Clock	157	3508-3524	Aluminum adapter plate	162
465-KFA6	Contact protection and isolating relay	157	3570 / 3572	Wall-mounted housing	162

4.2 Overview of microprocessor controllers - closed loop



baelz 64xx (96 x 96 mm) and baelz 65xx (96 x 48 mm)

3 types with 3 different outputs: on/off; open – stop – close; 4...20 mA; 230 V, 50/60 Hz

Controller type according to size and control output Order No.		Front panel housing 96 x 96 mm	Front panel housing 96 x 48 mm	Rail mounting	Protection class IP 65 for front	N° of selectable analogue inputs	Pt 100 Ω; 3-wire connection	Input 0/4...20 mA	Input 0/2...10 V	Continuous output 0/4...20 mA; 0/2...10 V	N° of digital inputs	2 nd setpoint (DI)	Remote setpoint (DI)	Forced - OPEN (DI)	Forced - CLOSE (DI)	Forced - STOP (DI)	N° of alarm relays	Continuous actual value output 0...10 V of Pt.100 - input	With RS 485 interface	Without keyboard, without LED display
PID pulse controller																				
6440/1-2.4*	6440-0002	X			X	3 ¹	X	X	X		1		X				1			
6440/2-2.4*	6440-0202	X			X	3 ¹	X	X	X		5	X	X	X	X	X	1	X		
6440/3-2.4*	6440-0302	X			X	3 ¹	X	X	X		4	X		X	X	X	2		X	
Motorized valve controller without position feedback, power supply: 230 V TPS: Three Position Step controller (Open - Stop - Close)																				
6490B/4-2.4	6490-1602	X			X		X				1	x ³		x ³	x ³	x ³	1			X
6490/2-2.4*	6490-0202	X			X	3 ¹	X	X	X		5	X	X	X	X	X	1	X		
6490/3-2.4	6490-0302	X			X	3 ¹	X	X	X		3			X	X	X	2		X	
6490/5-2.4	6490-0502	X			X	3 ¹	X	X	X		1		X				2	X		
6590B/4i-2.4	6590-1402			X			X				1	x ³		x ³	x ³	x ³	1		X	X
6590/1-2.4*	6590-0002	X			X	3 ¹	X	X	X		1		X				1			
6590/2-2.4*	6590-0202	X			X	3 ¹	X	X	X		5	X	X	X	X	X	1	X		
6590/3-2.4	6590-0302	X			X	3 ¹	X	X	X		3			X	X	X	2		X	
Controller with continuous output																				
6496/1-2.4*	6496-0002	X			X	3 ¹	X	X	X	X	1		X				2			
6496/2-2.4*	6496-0202	X			X	3 ¹	X	X	X	X	5	X	X	X	X	X	2	X		
6496/3-2.4	6496-0302	X			X	3 ¹	X	X	X	X	5	X	X	X	X	X	2		X	
6596/1-2.4*	6596-0002		X		X	3 ¹	X	X	X	X	1		X				2			
6596/2-2.4	6596-0202		X		X	3 ¹	X	X	X	X	5	X	X	X	X	X	2	X		
6596/3-2.4*	6596-0302		X		X	3 ¹	X	X	X	X	5	X	X	X	X	X	2		X	
Cascade controller with continuous output																				
6487/1-2.4	6487-0002	X			X	3 ²	X	X	X	X	1		x ⁴				2			
Cascade controller with motorized valve output																				
6497/1-2.4	6497-0002	X			X	3 ²	X	X	X		1		x ⁴				1			
Motorized valve controller without position feedback, power supply: 24 V TPS: Three Position Step controller (Open - Stop - Close)																				
6590/1-2.4-024	6590-0022	X			X	3 ¹	X				1		X				1			
6590/2-2.4-024	6590-0222	X			X	3 ¹	X	X	X		5	X	X	X	X	X	1	X		

¹ only one analogue input useable
*available from stock

² two analogue inputs useable
⁴ setpoint offset OFS (DI)

³ freely selectable by software

24 V or 115 V instead of 230 V on request

Heating and air conditioning applications:

<p>with 8, 12 or 16 control loops</p>	<p>with or without optimized start-up / stop</p>	<p>control of heat-exchangers for heating</p>	<p>for domestic hot water</p>
---------------------------------------	--	---	-------------------------------

Control of boilers including cascades:

Ventilation, air conditioning:

--	--

Control in the industry:

<p>program control for dyeing vats and pasteurization units</p>	<p>consumption measurements, summation</p>	<p>relief</p>
---	--	---------------

<p>cascade of cooling towers</p>	<p>control of presses</p>	<p>control of stentors, dryers, pasteurization units</p>
----------------------------------	---------------------------	--



baelz 5192

CONTROL DEVICE WITH TOUCH SCREEN

Unit for operating Baelz devices without own display or operating unit.

Can be connected to Modbus RTU protocol with an RS 485 interface to operate multiple devices. Connection to a higher-level control system with Modbus TCP protocol as well as further connection possibilities are also possible.

ADVANTAGES AT A GLANCE

- convenient operation and observation with touch display
- extensive visualization options
- as operator device for several Modbus slaves
- custom configuration of the user level
- trend logger
- online and trend display with multiple curves
- alarm monitoring and alarm display with color change
- event display (e.g. operating and alarm messages)
- VNC remote control via Internet
- as RS 485 Modbus RTU master or Modbus TCP client
- Ethernet interface for remote control and programming
- transfer of process data to other Modbus slaves

Technical specifications, baelz 5192

	baelz 5192-W-WB-43E	baelz 5192-W-WB-70EA
Designation	baelz 5192-W-WB-43E	baelz 5192-W-WB-70EA
Housing	plastic	plastic
Screen size (inches)	4.3	7.0
Resolution max. (inches)	480 x 272	800 x 480
Brightness (cd/m²)	500	300
Dimensions, WxHxD (mm)	128 x 102 x 32	201 x 147 x 34
Cut-out, WxH (mm)	119 x 93	192 x 138
Weight (approx., kg)	0.3	0.85
USB host	1 x USB 2.0	
COM1	RS 232 / 485	
COM3	RS 485	
Processor	32 bit Cortex A8 600 MHz	
Real time clock	Yes	
Touch panel	TFT; 4-wire resistive	
Contrast ratio	500:1	
Colors	16 M	
Storage	128 MB Flash	
RAM	128 MB	
Ethernet interface	10/100 Base-T	
Temperature range (°C)	0...50	
Storage temperature range (°C)	-20...+60	
Atmospheric humidity	10...90% RH non-condensing	
Degree of protection at the front	IP 65	
Power supply	+24 V DC ±20%	
Current consumption	350 mA @ 24 V DC	

Options / Supplements / Accessories	
Option baelz 5192-W-WB ... including preconfiguration for max. :	3 control loops, 46 data points, 8 trend variables, 1 P+I diagram
Individual supplements for preconfiguration in the factory:	Basic configuration Data point Trend variable Control loop with max. 10 variables Plant picture with max. 20 variables
Important: Required power supply baelz 6208/3-1.0 A (Order No. 6208-022)	
Accessories: Connection cable baelz 5192-W-WB-RS485 with 9-pin connector for connection to touch screen, other end for connection to RS 485. Cable length 3 m	

Housing dimensions baelz 5192-W-WB-43E

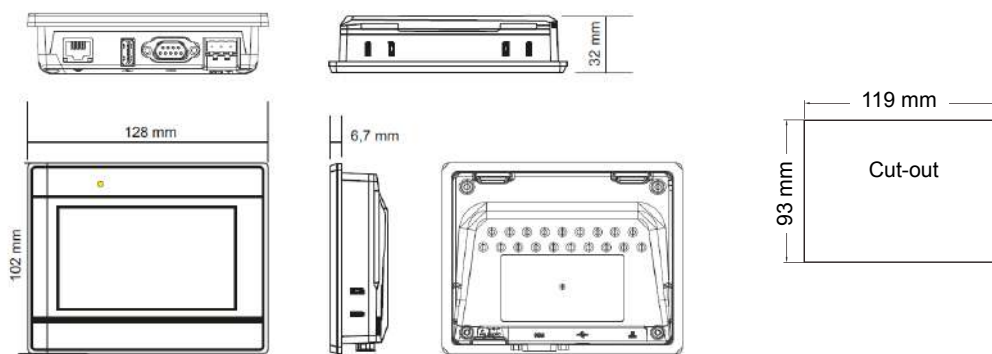

Housing dimensions baelz 5192-W-WB-70EA

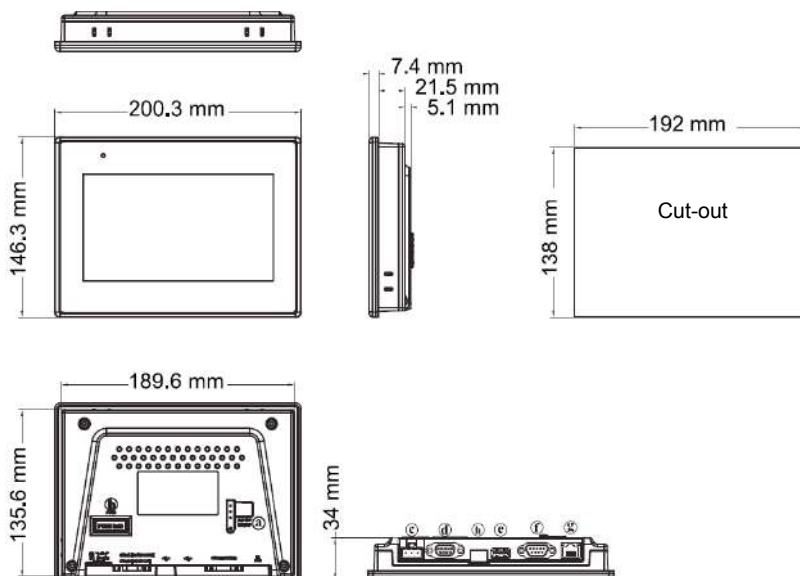



baelz 6164B-W2



baelz 6164B

baelz 6164B

MICROPROCESSOR COMPACT CONTROLLER

for temperature control in heating systems.

Microprocessor compact controllers μ Climatron baelz 6164B / 6164B-W2 are used to regulate the feed temperature depending on the outside temperature as required.

ADVANTAGES AT A GLANCE

- as three-point step/three-point/two-point or continuous controller with analog output 0/2 ... 10V
- constant setpoint or heating curve with 5 coordinating points
- simple configuration, operation and parameterization with only 4 buttons & LCD display
- pump blocking protection
- Legionella protection function
- boiler charging function
- jet control (for jet pumps)
- sensor monitoring
- switching time deferral depending on the outside temperature
- suitable for hot water or steam systems (starting circuit)

Specifications microprocessor compact controller μ Climatron baelz 6164B / 6164B-W2 / 6164B-W2-SM

	6164B	6164B-W2	6164B-W2-SM
Control loops/circuits	max. 2		
Controller type	Three-point step/three-point/two-point or continuous controller		Continuous controller
Analog inputs	5: PT100 (measuring range: -40°C ... + 120°C)		5: 3 x PT1000; 2 x PT100
	NTC, 0/4 ... 20 mA, Re = 5.9 Ω ; 0/2 ... 10 V, Re = 160 k Ω , Potentiometer selectable		
Analog outputs	2x (0/2...10V), I _{max} = 5 mA		
Digital inputs	2		
Digital outputs	6x relays		2 x relays
Digital input and transducer supply voltage	24 V DC, I _{max} = 14 mA		
Connection	Screw-type terminals		
Interface	RS485 Modbus-RTU		
Display	LCD with backlight 2x24 characters		
Mounting	Panel front installation	Wall-mounted housing (also suitable for DIN rail mounting)	
Housing	plastic	Plastic housing with transparent door (optionally lockable)	
Dimensions WxHxD (mm)	144 x 96 x 90	233 x 185 x 118	
Ingress protection rating	IP 55 (front)	IP 65	
Power supply	230 V / (special voltages on request: 115 V / 24 V), 50/60 Hz		
Cable glands	-	6 x M20 x 1,5, 1 x M16 x 1,5	6 x M20 x 1,5, 2 x M16 x 1,5
Weight, approx. (kg)	0,7	1.5	
Ambient temperature (°C)	0...50		
Ambient humidity	5...90% RH (non-condensing)		

Note:

- baelz 6164B-W2-SM suitable for Hydropilot baelz 141-OV
- Standard software (included in the price) available in: German, Danish, English, Flemish, French, Italian, Dutch
- Software for control technology, see baelz 4614, software for remote control, see baelz 4615-WinBasTools, WinBasTools-Par
- Adapter for switch cabinet interior installation available

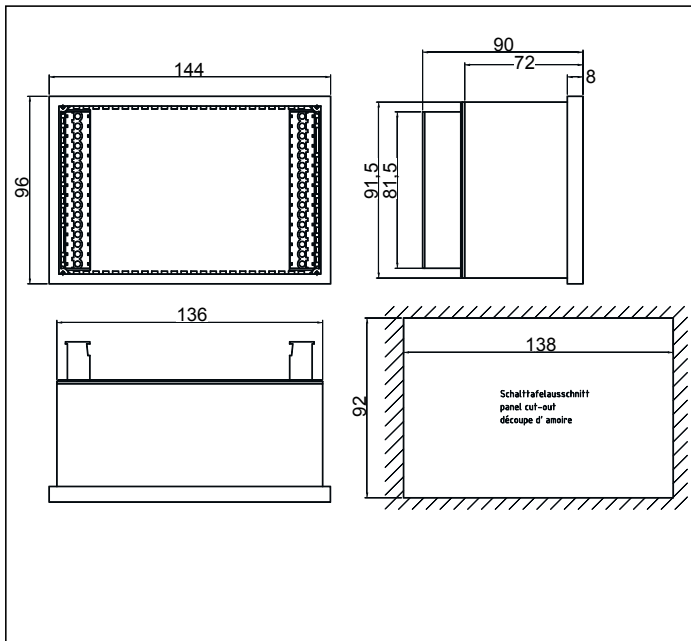

Dimensions 6164B, Panel controller

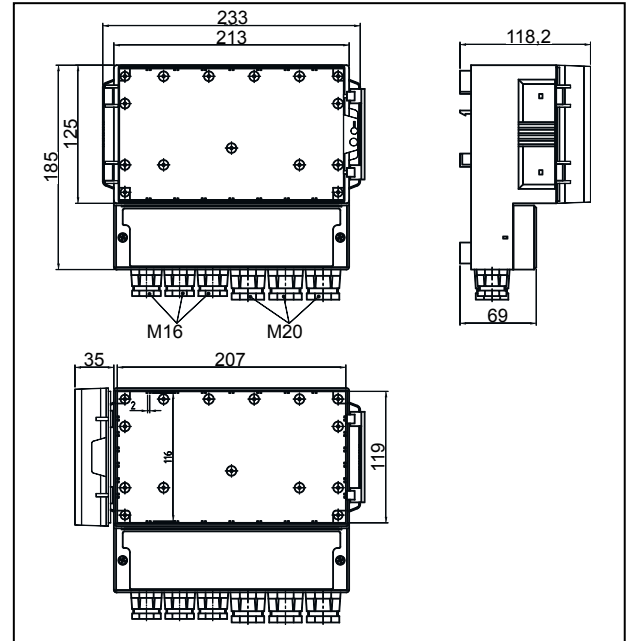

Dimensions 6164B-W2, wall-mounted unit

μ Climatron baelz 6164B

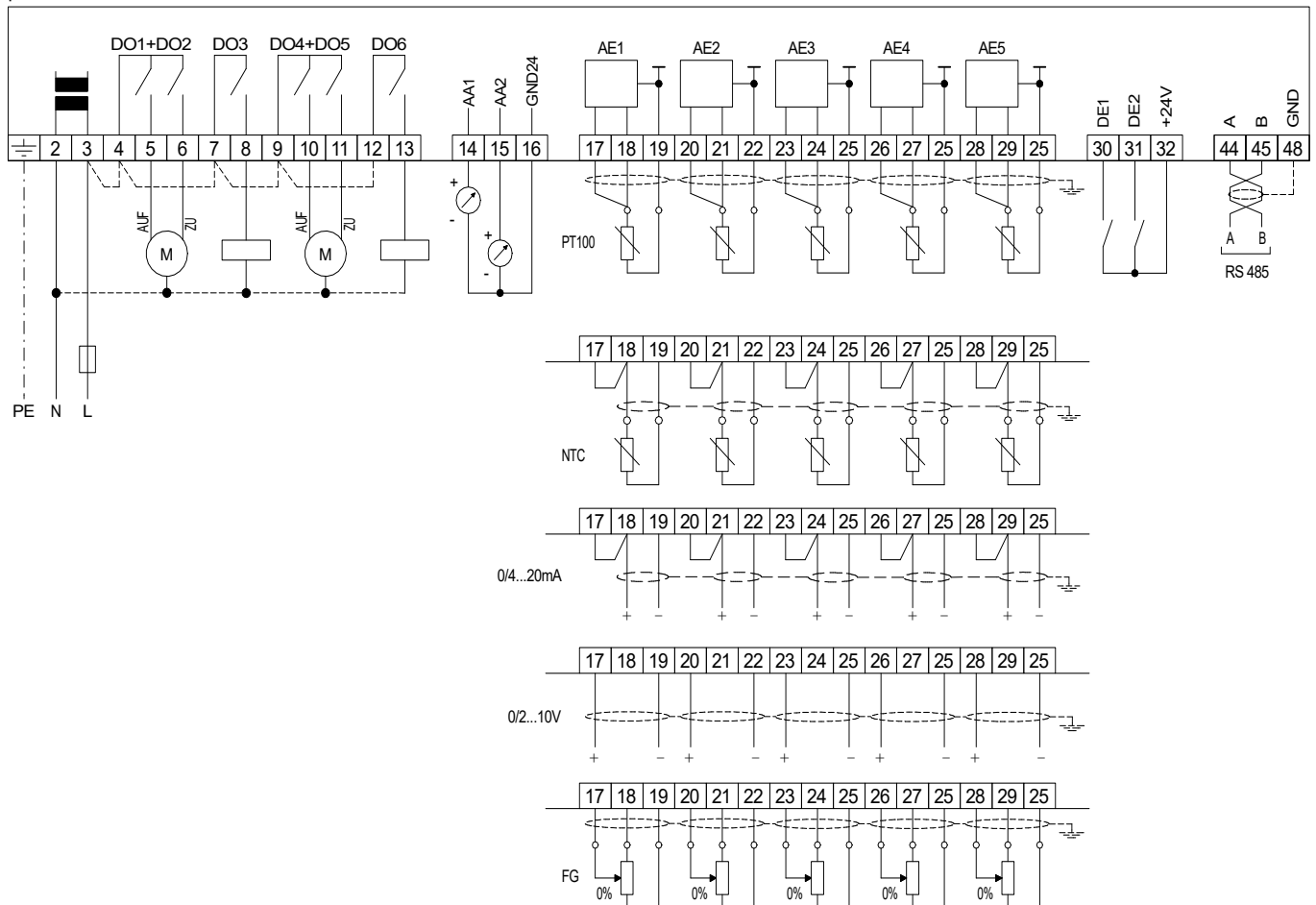

Example of a connection diagram: 6164B, Panel controller



baelz 6200-192-4

baelz 6200

MICROPROCESSOR CONTROLLER „BUSPILOTRONIC“

The standard controller for major BACS projects

For regulation, control and monitoring of industrial and domestic processes.

ADVANTAGES AT A GLANCE

- Multiprocessor technology
- modular system - expandable at any time
- easy operation with user-friendly menus
- several installation options
- various operating interfaces selectable
- multi-circuit control system - up to 16 control loops
- integrated PLC control without programming device
- monitoring and reducing energy consumption

Technical specifications microprocessor controller baelz 6200 ...

Control loops/circuits	max. 16
Controller type	freely selectable using plug-in cards
Analog inputs	NTC: 3.11 (-40°C to +60°C); 3.12 (0°C to +60°C); 3.13 (0°C to +140°C) PT100: 2.21 (-40°C to +60°C); 2.4 (0°C to +300°C); 2.49 (-40°C to +120°C) Humidity: 5.4 (0 to 100% rh) 0/4 ... 20 mA, Re = 5.9 Ω; 0/2 ... 10 V, Re = 160 kΩ; Potentiometer: 100 Ω ... 5 kΩ
Analog output	0/4...20 mA, Re = 500 Ω; 0/2...10 V, I _{max} = 5 mA
Digital input	Re = 4 kΩ (low = 0 VDC; high = 15...24 VDC)
Digital input and transducer supply voltage	24 VDC
Connection	Screw-type terminals, 9-pin female connector RS232
Interface	RS485 Modbus-RTU
Display	LCD backlight with 8x40 characters for plain text display *
Housing	plastic
Power supply (depending on the type)	230 V / (special voltages on request: 115 V / 24 V), -15% / + 10%, 50/60 Hz
Relay	with potential-free contact; Switching capacity 250 VAC / 3 A; Spark suppressor 10 nF + 100 Ω
Ambient temperature (°C)	Operating: 0...50; Transport / Storage: -20...+ 60
Ambient humidity	5...90% RH (non-condensing)
Function keyboard for configuration, operation and parameterization on site *	
Up to 16 LEDs for displaying binary signals (relays 1-16), labeled	
Battery for data backup in case of power failure	
Software available in the following languages: German, English, French, Flemish, Italian, Dutch	

* except for 6200-i-3

Options / notes	Remarks
Ext. Power supply unit Order No. 6208-012 is required if more than 1 D/I-D/O card(s) are inserted.	
Only one M-Bus card baelz 6200-M can be equipped per device. Order No. 6200-101	
Software for baelz 4614 control system on request.	
baelz 4615 remote control and parameter expression program on request.	
Pre-wiring of the controller: supplement baelz 3572	only for 6200-W4
Further accessories available on request.	

Type	Slots for max. ... cards	Mounting version
6200-i-3...	6 *	Switch cabinet interior installation
6200-192-4...	4	Panel front installation
6200-9,5-5...	5	Panel front installation
6200-19-10...	10	Panel front installation
6200-19-20...	20	Panel front installation
6200-W4...	4	Wall-mounted unit

* for 4 or more cards: with additional device including flat ribbon bus cable approx. 0.15 m

Number of cards and weight microprocessor controller baelz 6200 ...					
Type	Number of cards	Weight approx. (kg)	Type	Number of cards	Weight approx. (kg)
6200-i-3 / 1X	1	1,4	6200-19-20 / 1X	1	4,6
6200-i-3 / 2X	2	1,6	6200-19-20 / 2X	2	4,8
6200-i-3 / 3X	3	1,8	6200-19-20 / 3X	3	5,0
6200-i-3 / 4X	4 *	3,2	6200-19-20 / 4X	4	5,2
6200-i-3 / 5X	5 *	3,4	6200-19-20 / 5X	5	5,7
6200-i-3 / 6X	6 *	3,6	6200-19-20 / 6X	6	5,9
6200-192-4 / 1X	1	1	6200-19-20 / 7X	7	6,1
6200-192-4 / 2X	2	1,2	6200-19-20 / 8X	8	6,3
6200-192-4 / 3X	3	1,4	6200-19-20 / 9X	9	6,8
6200-192-4 / 4X	4	1,6	6200-19-20 / 10X	10	7,0
6200-9,5-5 / 1X	1	1,7	6200-19-20 / 11X	11	7,2
6200-9,5-5 / 2X	2	1,9	6200-19-20 / 12X	12	7,4
6200-9,5-5 / 3X	3	2,1	6200-19-20 / 13X	13	7,9
6200-9,5-5 / 4X	4	2,3	6200-19-20 / 14X	14	8,1
6200-9,5-5 / 5X	5	2,8	6200-19-20 / 15X	15	8,3
6200-19-10 / 1X	1	2,5	6200-19-20 / 16X	16	8,5
6200-19-10 / 2X	2	2,7	6200-19-20 / 17X	17	9,0
6200-19-10 / 3X	3	2,9	6200-19-20 / 18X	18	9,2
6200-19-10 / 4X	4	3,1	6200-19-20 / 19X	19	9,4
6200-19-10 / 5X	5	3,6	6200-19-20 / 20X	20	9,6
6200-19-10 / 6X	6	3,8	6200-W4 / 1X	1	3,5
6200-19-10 / 7X	7	4	6200-W4 / 2X	2	3,7
6200-19-10 / 8X	8	4,2	6200-W4 / 3X	3	3,9
6200-19-10 / 9X	9	4,7	6200-W4 / 4X	4	4,1
6200-19-10 / 10X	10	4,9			

* for 4 or more cards: with additional device including flat ribbon bus cable approx. 0.15 m

Note: Other card configurations are possible if required.

Please note the following table.

Type	Slot 1, only for cards: B, BAA	Slots only for cards BENT, BEAANT, DENT	Remaining slots, only for cards: BE, BEAA, DE, DA, M
6200-i-3...		4	
6200-192-4...		-	
6200-9,5-5...		5	
6200-19-10...		5 + 9	
6200-19-20...		5, 9, 13, 17	
6200-W4...	-		

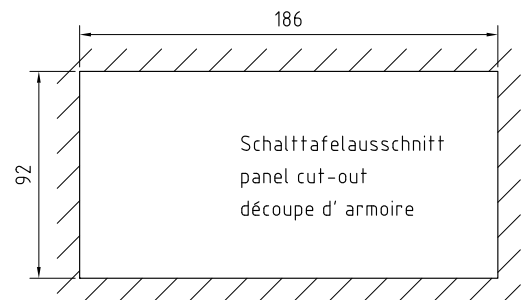
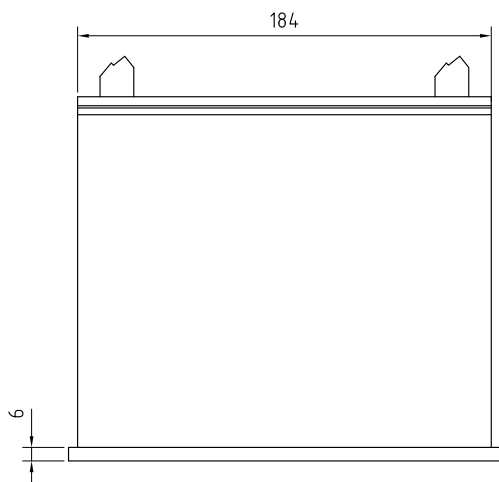
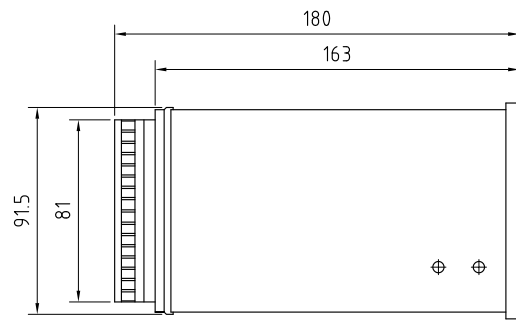
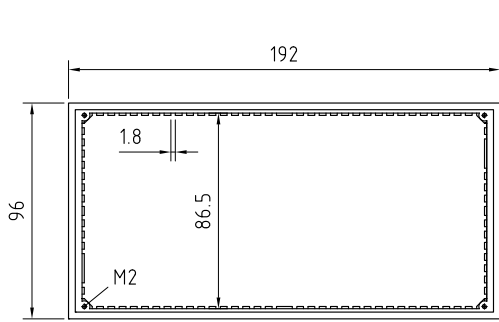

Dimensions baelz 6200-192-4

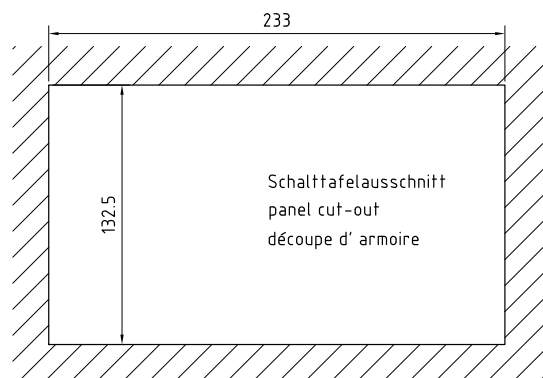
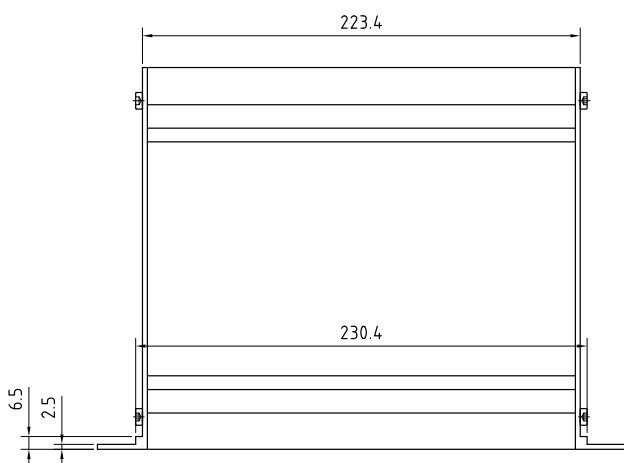
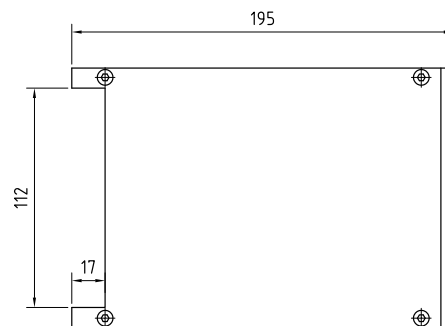
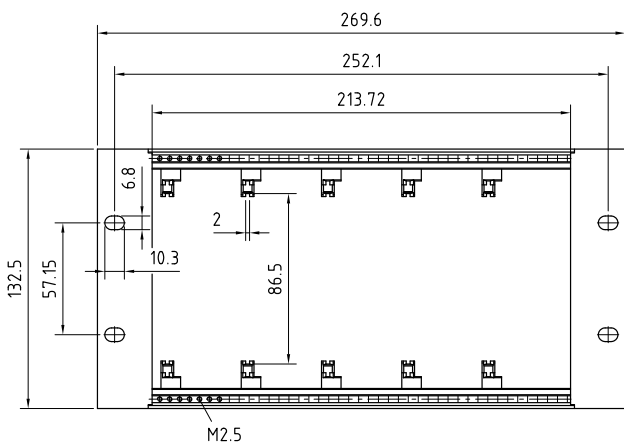

Dimensions baelz 6200-9,5-5

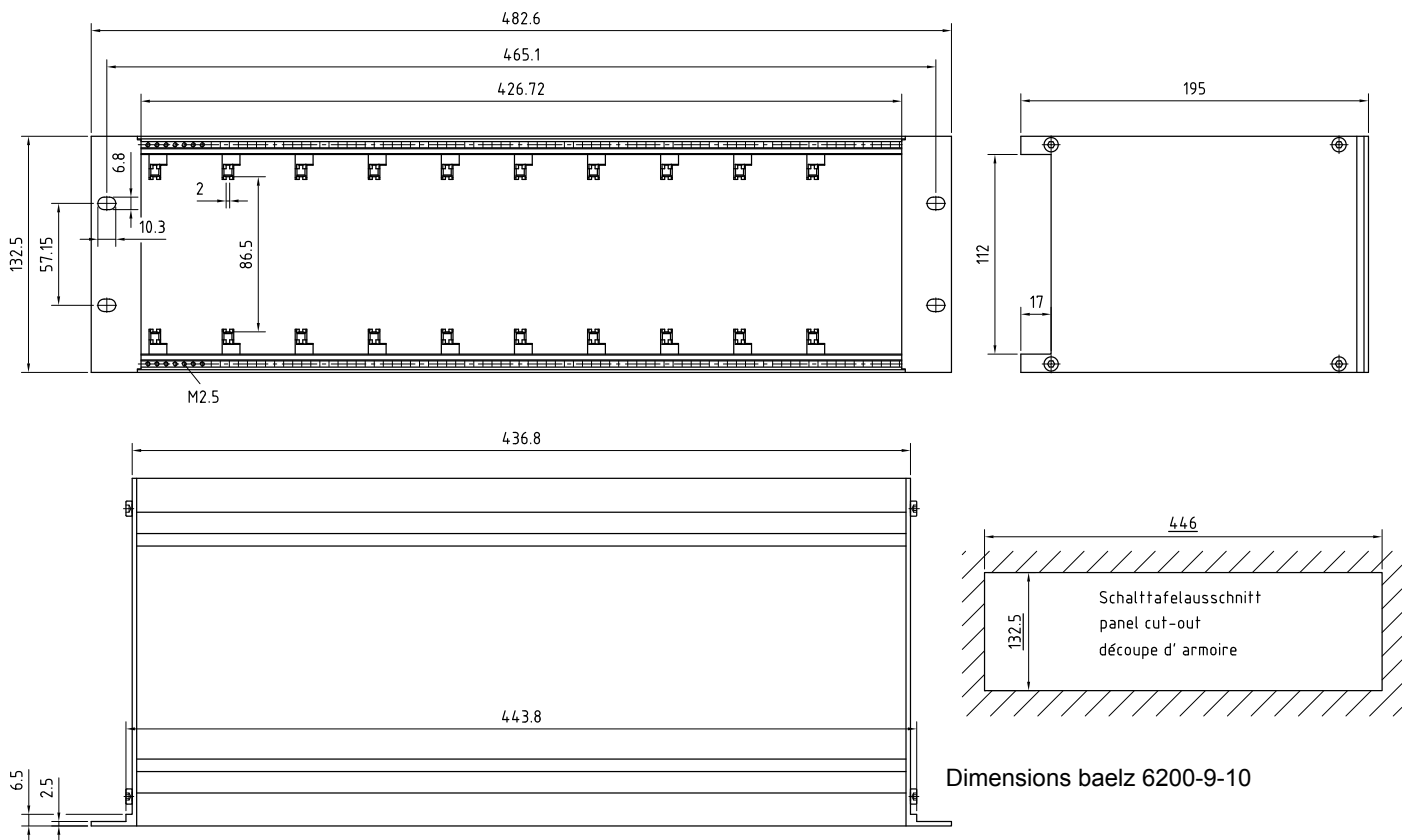

Type	Dimensions WxHxD (mm)	Panel controller cut-out WxH (mm)
6200-19-10...	482,6 x 132,5 x 195	446 x 132,5
6200-19-20...*	482,6 x 265,9 x 195	446 x 265,9

* The housing of the 6200-19-20 differs only in width from the 6200-19-10 housing.

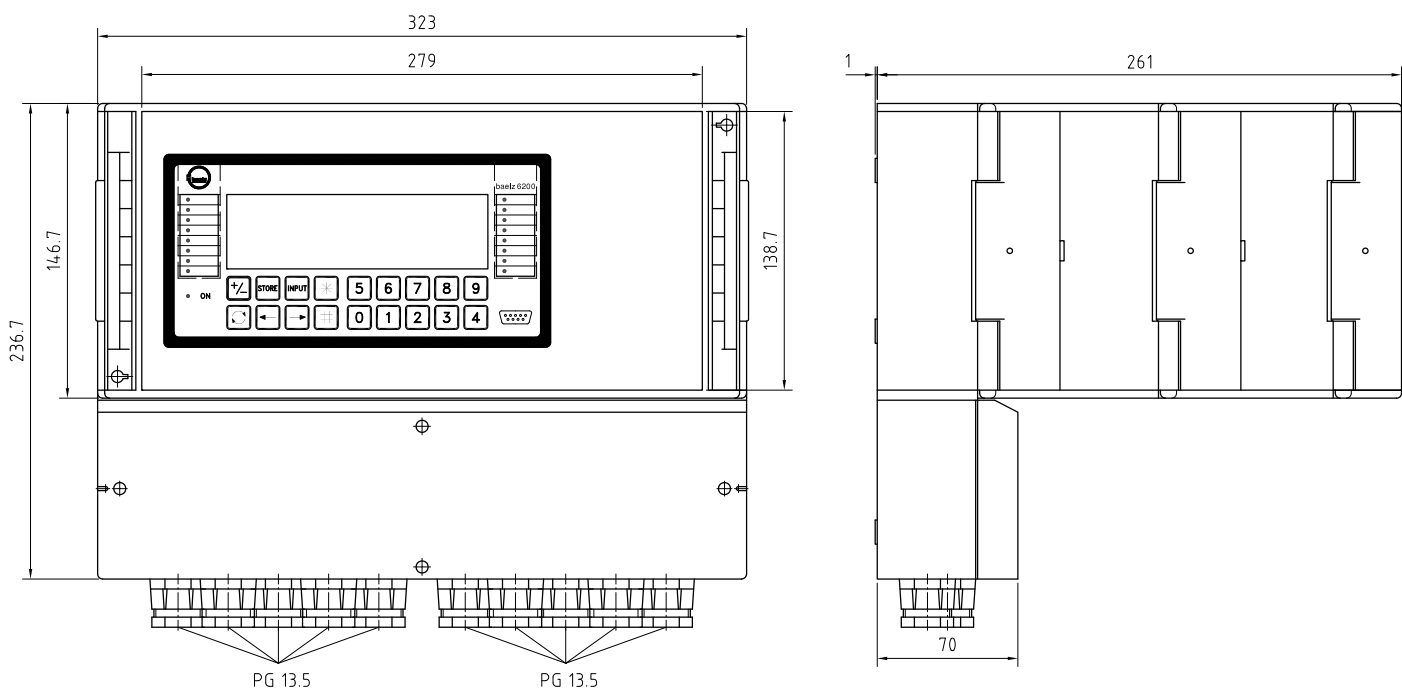

Cards for baelz 6200 microprocessor controller									
Type	Description	Characteristics	Weight approx. (kg)	Relay	Inputs	Analog-outputs	Modem-connection	Power supply	
6200-B	Basic card	with microprocessor 65S02, microcontroller, SCC, ROM and RAM, RS485 connection, clock, battery for data backup in case of power failure, including sub-card 6200-S (price including standard software 4611)	0.2	4 (2 switches, 2 NO contacts)	4 digital, 4 analog	-	not prepared for modem connection	230 V, 50/60 Hz, 12 W	
6200-BAA	Basic card	with microprocessor 65S02, microcontroller, SCC, ROM and RAM, RS485 connection, clock, battery for data backup in case of power failure, including sub-card 6200-S (price including standard software 4611)	0.2	3 (1 switch, 2 NO contacts)	4 digital, 4 analog	2 analog 0/2 ... 10V or 0/4 ... 20 mA	No	230 V, 50/60 Hz, 12 W	
6200-BAA.B	Basic card		0.2				on front card, BEAA (NT)		
6200-S	Subcard	Microprocessor 65S02, SCC, RAM, EPROM (price includes standard software 4611)	0.1	-	-	-	no modem connection on basic card	-	
6200-BE	Supplementary card	Microcontroller	0.2	4 (2 switches, 2 NO contacts)	4 digital, 4 analog	-	No	230 V, 50/60 Hz, 12 W	
6200-BENT	Supplementary card	Microcontroller	0.5						
6200-BE.C	Supplementary card	Microcontroller	0.2						
6200-BENT.C	Supplementary card	Microcontroller	0.5						
6200-BEAA	Supplementary card	Microcontroller	0.2	3 (1 switch, 2 NO contacts)	4 digital, 4 analog	2 analog 0/2 ... 10V or 0/4 ... 20 mA	No	-	
6200-BEAA.C	Supplementary card	Microcontroller	0.2						
6200-BEAAANT	Supplementary card	Microcontroller	0.5						
6200-BEAAANT.C	Supplementary card	Microcontroller	0.5						
6200-DA	Relay card	Microcontroller	0.2	8 (6 switches, 2 NO contacts)	8 digital	-	-	-	
6200-DE	Digital input card	Microcontroller	0.2	-	24 digital	-	-	-	
6200-DENT	Digital input card	Microcontroller	0.5						
6200-DENT-RS485	Digital input card	Microcontroller, RS485 connection	0.5						
6200-M	M-bus card	Microcontroller. For reading max. 4 on-site heat meters with M-Bus protocol	0.2	-	-	-	-	-	

Note: The 6200-DENT-RS485 card is only suitable for baelz 6200-i-3.

baelz 6490 / 6590

PID 3-POINT STEP CONTROLLER

Industrial controller with special PID stepper algorithm.

baelz 6X90 / 6X90B / 6X90B-y μ Celsitron microprocessor controllers are compact and reliable controllers suitable for many industrial control applications, e.g.: in dryers, reactors, autoclaves and heat exchangers.

ADVANTAGES AT A GLANCE

- PI/PID control response with three-point output
- Easy operation with 3 or 4 keys
- Auto tuning, self-adaptation of the control parameters
- Option: RS485 Modbus RTU for connection to master computer
- Control digital input for OPEN, CLOSE, STOP, SP2, REM./LOC.
- Setpoint ramp with selectable gradient
- Manual/automatic switchover
- Thermocouple with ext. converter baelz 6261-Thermo
- Two-point/three-point selectable
- Up to 2 alarms: fixed, sliding, tolerance band/range
- LED status display



baelz 6490B-y



baelz 6590

Technical specifications, baelz 6490/6590 (6X90 stands for both types)

	6490...	6590...
Controller type	PID three-point modulating controller (6X90B ... for temperature)	
Analog inputs	PT100, 2.4 = 0...300°C or 2.2 = 0...400°C (other measuring ranges on request) Connection in 3-core technology; 0/4 ... 20 mA, Re = 50 Ω ; 0/2 ... 10 V, Re = 100 k Ω	
Analog output for actual value	0...10V corresponds to 0...300°C (2.4) or 2.2 = 0...400°C (2.2) I _{max} = 2 mA	
Digital inputs	high active, Re = 1 k Ω ; open / 0 VDC = low, 12 ... 24 VDC = high	
Digital input and transducer supply voltage	24 VDC, I _{max} = 60 mA	
Interface	RS485 Modbus protocol in RTU mode 1200 to 19200 baud; 1 start bit, 8 data bits, 1 stop bit, no parity	
Display	2 LED displays for setpoint and actual value	
Mounting	Panel front installation	
Housing	plastic	
Dimensions WxHxD (mm)	96 x 96 x 135	48 x 96 x 140
Ingress protection rating	IP 65 (front)	
Power supply	230VAC (special voltages on request 115VAC, 24VAC, 50/60Hz, 24 VDC), -15%/+10%, 7VA	
Weight, approx. (kg)	0.6	0.5
Ambient temperature (°C)	Operating: 0...50; Transport / Storage: -25...+ 65	

Options / Supplements	Remarks
2 inputs 0/4 ... 20 mA	
2 inputs 0/2 ... 10 V	
Differential temperature 0...50 K	
Measuring range PT100: -30...+ 60°C	
Calibration of measuring input PT100	for connection to Zener barriers
RS 485 - preload S15	for connection to remote maintenance module baelz 5279-NB (only for devices with RS 485)

Note:

- Software for control technology, see baelz 4614
- Wall-mounted housing: Order No. 3570-001
- Adapter for rail mounting: Order No. 3506-004

Inputs and outputs, baelz 6490/6590 (6X90 stands for both types)							
Type	Measuring inputs	Controller output	Digital inputs	Actual value output 0...10 V (PT100)	Alarm relay with potential-free changeover contact 250 V AC / 3 A.	with RS485 interface Modbus RTU	with Y bar graph display
6X90/2	2 measuring inputs can be assigned either with the process variable or the external setpoint: PT100, 0/2...10 V or 0/4...20 mA	Three-point step / three-point / two-point selectable	5x (open, close, stop, external / internal and 2nd setpoint)	1x 0...10 V (PT100)	1x	No	No
6X90/3			3x (open, close, stop)	-	2x	Yes	No
6X90/4			3x (open, close, stop)	1x 0...10 V (PT100)	2x	Yes	No
6X90/5			1x for switching external / internal setpoint	1x 0...10 V (PT100)	2x	No	No
6X90B/0			-	-	1x	No	No
6X90B/4	1x PT100, to connect in three-wire circuit		1x (open, close, stop or 2nd setpoint)	-	1x	Yes	No
6X90B-y/3			-	-	1x	Yes	Yes

Housing dimensions baelz 6490

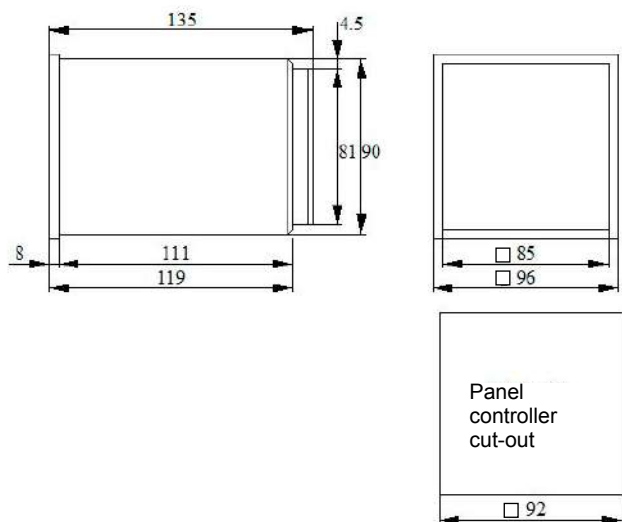

Housing dimensions baelz 6590

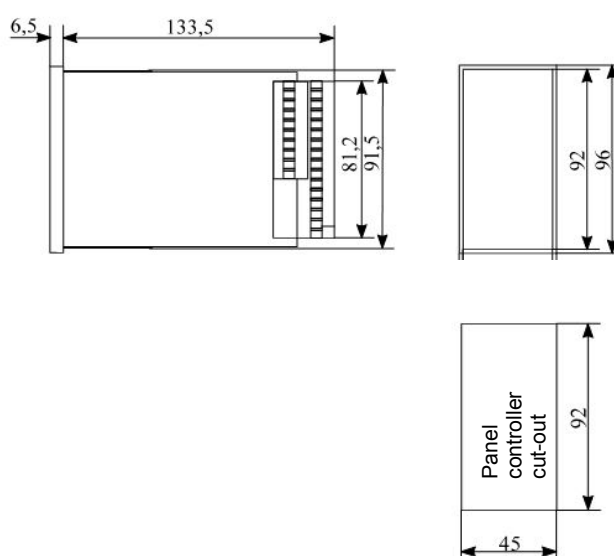

Equipment overview Type / Version baelz 6490 ... / 6590 ...					
Equipment	.../0	.../2	.../3	.../4	.../5
PI (D) - three-point step output	✓	✓	✓	✓	✓
Alarm relay 1	✓	✓	✓	✓	✓
1 measuring input Pt100	✓	✓	✓	✓	✓
1 measuring input 0/4 ... 20 mA		✓	✓	✓	✓
1 measuring input 0/2 ... 10 V		✓	✓	✓	✓
Integrated transmitter supply voltage 24 V DC		✓	✓	✓	✓
1 digital input (external setpoint)					✓
4 digital inputs (open, close, stop, setpoint 2)			✓	✓	
5 digital inputs (open, close, stop, ext. setpoint, setpoint 2)		✓			
1 Pt100 actual value output 0...10 V		✓		✓	✓
1 bus interface RS 485 (Modbus RTU)			✓	✓	
Alarm relay 2			✓	✓	✓

Connection diagram baelz 6x90

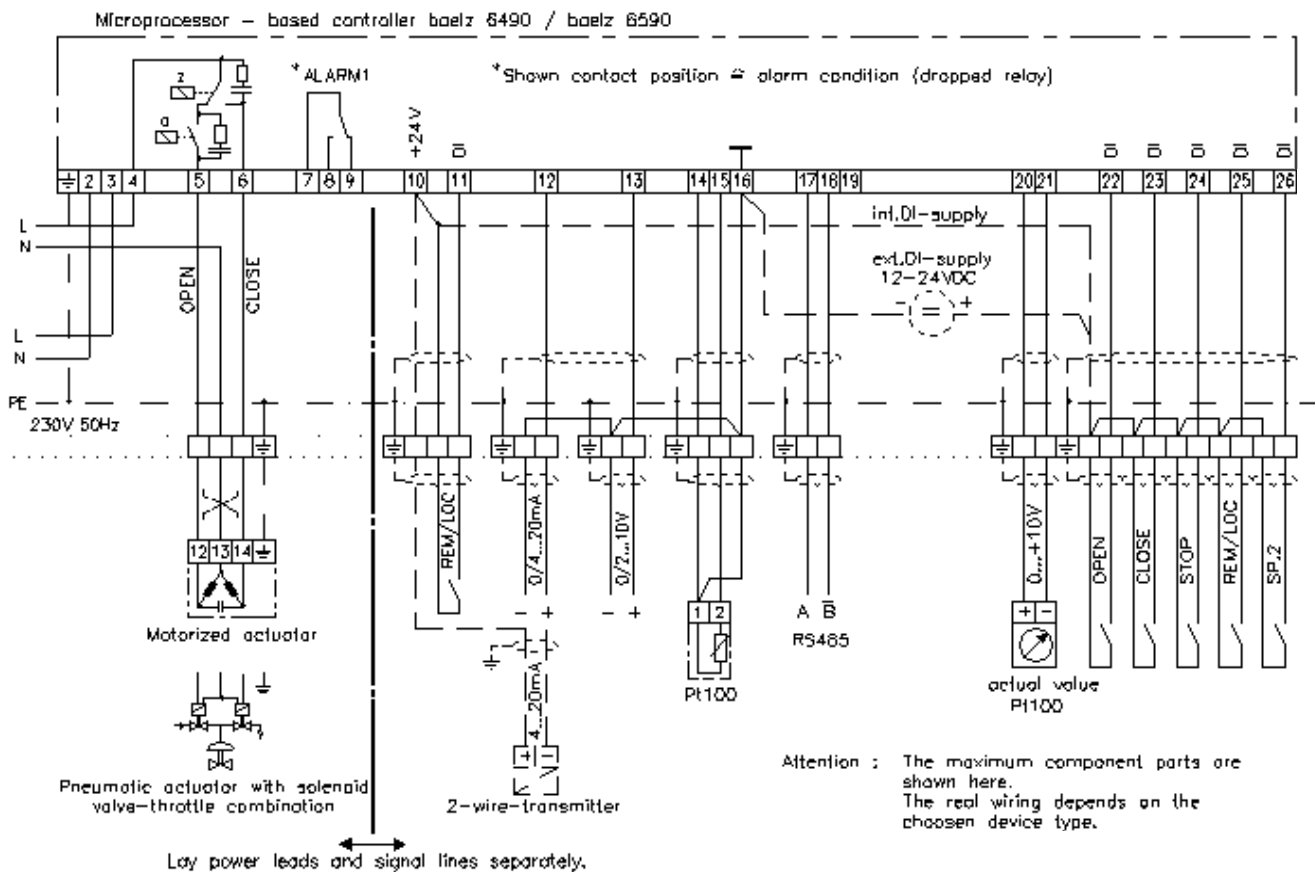

baelz 6496 / 6596

PID CONTINUOUS CONTROLLER

Constant controller with continuous control signal.

baelz 6X96 μ Celsitron microprocessor controllers are compact and reliable controllers suitable for many industrial control applications, e.g.: in dryers, reactors, steam generators and superheated steam coolers (desuperheaters).

ADVANTAGES AT A GLANCE

- P/PD/PI/PID control behavior with continuous control signal
- Easy operation with 4 buttons
- Auto tuning, self-adaptation of the control parameters
- Option: RS485 Modbus RTU for connection to master computer
- Standard housing 96x96 mm / 96x48 mm
- Control digital input for OPEN, CLOSE, STOP, SP2, REM./LOC.
- Setpoint and positioning ramp with selectable gradient
- Manual/automatic switchover
- Measuring inputs PT 100, 0 / 2-10V, 0 / 4-20mA
- Thermocouple with ext. converter baelz 6261-Thermo
- 2 separate LED displays for setpoint and actual value
- 2 alarms standard: fixed, sliding, tolerance band/range
- LED status display



baelz 6496



baelz 6596

Technical specifications, baelz 6496/6596 (6X96 stands for both types)

	6496...	6596...
Controller type	PID continuous controller	
Analog inputs	PT100, 2.4 = 0...300°C or 2.2 = 0...400°C (other measuring ranges on request) Connection in 3-core technology; 0/4 ... 20 mA, Re = 50 Ω ; 0/2 ... 10 V, Re = 100 k Ω	
Analog output for actual value	0...10V corresponds to 0...300°C (2.4) or 2.2 = 0...400°C (2.2) I _{max} = 2 mA	
Digital inputs	high active, Re = 1 k Ω ; open / 0 VDC = low, 12 ... 24 VDC = high	
Digital input & transducer supply voltage	24 VDC, I _{max} = 60 mA	
Interface	RS485 Modbus protocol in RTU mode 1200 to 19200 baud; 1 start bit, 8 data bits, 1 stop bit, no parity	
Display	2 LED displays for setpoint and actual value	
Mounting	Panel front installation	
Housing	plastic	
Dimensions WxHxD (mm)	96 x 96 x 135	48 x 96 x 140
Ingress protection rating	IP 65 (front)	
Power supply	230 V / (special voltages on request: 115 V / 24 V), -15% / + 10%, 50/60 Hz	
Weight, approx. (kg)	0.6	0.5
Ambient temperature (°C)	Operating: 0...50; Transport / Storage: -25...+ 65	

Options / Supplements	Remarks
2 inputs 0/4 ... 20 mA	
2 inputs 0/2 ... 10 V	
Differential temperature 0...50 K	
Calibration of measuring input PT100	for connection to Zener barriers
RS 485 - preload S15	for connection to remote maintenance module baelz 5279-NB (only for devices with RS 485)

Note:

- Software for control technology, see baelz 4614
- Wall-mounted housing: Order No. 3570-001
- Adapter for rail mounting: Order No. 3506-004

Inputs and outputs, baelz 6496/6596 (6X96 stands for both types)						
Type	Measuring inputs	Controller output	Digital inputs	Actual value output 0...10 V (PT100)	potential-free alarm relay 250 V AC / 3 A	with RS485 interface Modbus RTU
6x96/1	2 measuring inputs can be assigned either with the process variable or the external setpoint: PT100, 0/2...10 V or 0/4...20 mA	1x 0/2...10 V oder 0/4...20 mA selectable	1x for switching external / internal setpoint	-	2x	No
6X96/2			5x (open, close, stop, external / internal and 2nd setpoint)	1x 0...10 V (PT100)	2x	No
6X96/3			With interface RS 485 Modbus RTU 5x (open, close, stop, external / internal and 2nd setpoint)	-	2x	Yes
6496/2-2.4-S7.1/ S8.1-24 V DC			2 measuring inputs as above, but switchable with special software S16	5x (open, close, stop, external / internal and 2nd setpoint)	1x 0...10 V (PT100)	2x

Housing dimensions baelz 6496

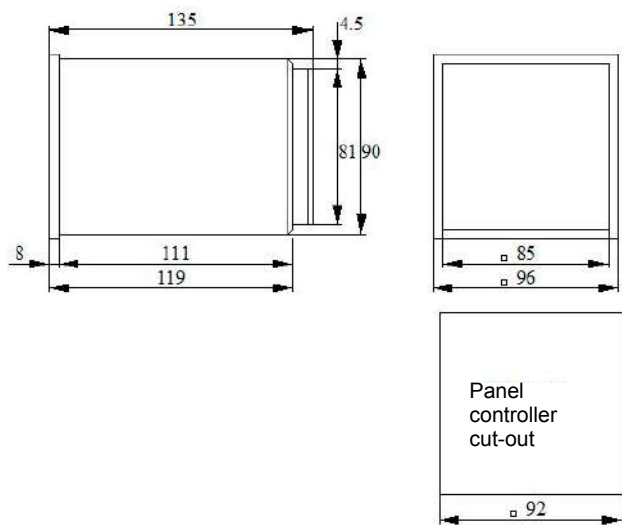

Housing dimensions baelz 6596

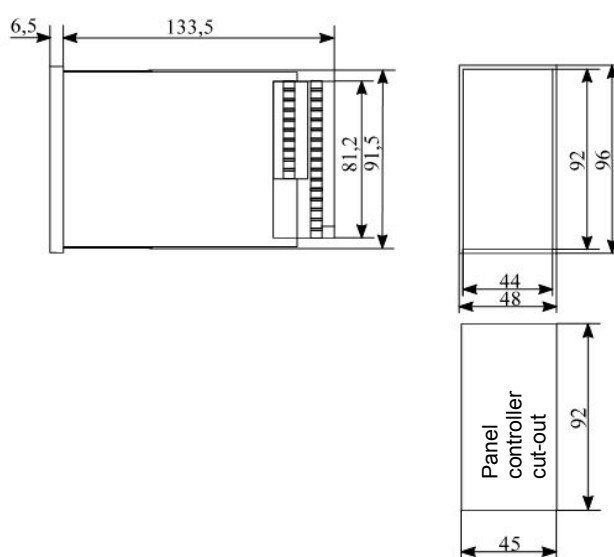

Overview features depending on type / version baelz 6496 ... / 6596 ...				
	Equipment	additional right controller card		
		.../1	.../2	.../3
Basic version	1 measuring input Pt100	✓	✓	✓
	1 measuring input 0/4 ... 20 mA	✓	✓	✓
	1 measuring input 0/2 ... 10 V	✓	✓	✓
	integrated supply voltage 24 V DC (for external two-wire transmitter and digital input)	✓	✓	✓
	1 digital input REM/LOC	✓	✓	✓
Options	5 digital inputs		✓	✓
	1 Pt100 actual value output 0...10 V		✓	
	1 serial interface RS 485			✓

Connection diagram baelz 6x96

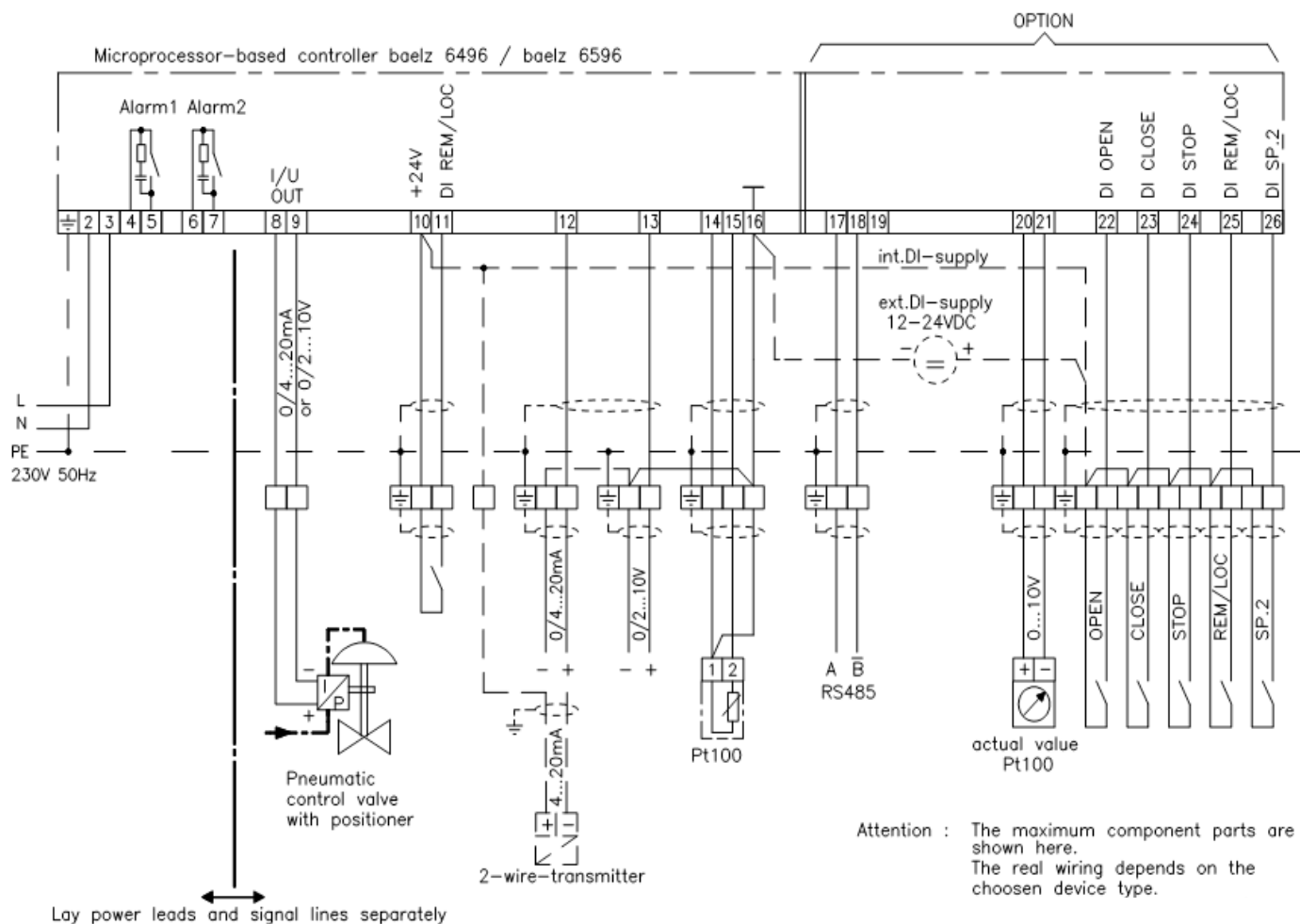

baelz 6497 / 6597

PID 3-POINT STEP CONTROLLER

PID three-point modulating controller with setpoint shift input or P/PID cascade controller

baelz 6X97 μ Celsitron microprocessor controllers are compact and reliable controllers suitable for many industrial control applications, e.g.: in dryers, reactors, autoclaves and heat exchangers.

ADVANTAGES AT A GLANCE

- PI/PID control response with three-point output
- Easy operation with 3 or 4 keys
- Auto tuning, self-adaptation of the control parameters
- Option: RS485 Modbus RTU for connection to master computer
- Standard housing 96x96 mm / 96x48 mm
- Control digital input for OPEN, CLOSE, STOP, SP2, REM./LOC.
- Setpoint ramp with selectable gradient
- Manual/automatic switchover
- Measuring inputs PT 100, 0 / 2-10V, 0 / 4-20mA
- Thermocouple with ext. converter baelz 6261-Thermo
- two-point/three-point selectable
- 2 separate LED displays for setpoint and actual value
- Up to 2 alarms: fixed, sliding, tolerance band/range
- LED status display



baelz 6497

Technical specifications, baelz 6497/6597 (6X97 stands for both types)

	6497...	6597...
Controller type	PID continuous controller	
Analog inputs	PT100, 2.4 = 0...300°C or 2.2 = 0...400°C (other measuring ranges on request) Connection in 3-core technology; 0/4 ... 20 mA, Re = 50 Ω ; 0/2 ... 10 V, Re = 100 k Ω	
Analog output for actual value	0...10V corresponds to 0...300°C (2.4) or 2.2 = 0...400°C (2.2) I _{max} = 2 mA	
Digital inputs	high active, Re = 1 k Ω ; open / 0 VDC = low, 12 ... 24 VDC = high	
Digital input and transducer supply voltage	24 VDC, I _{max} = 60 mA	
Interface	RS485 Modbus protocol in RTU mode 1200 to 19200 baud; 1 start bit, 8 data bits, 1 stop bit, no parity	
Display	2 LED displays for setpoint and actual value	
Mounting	Panel front installation	
Housing	plastic	
Dimensions WxHxD (mm)	96 x 96 x 135	48 x 96 x 140
Ingress protection rating	IP 65 (front)	
Power supply	230 V / (special voltages on request: 115 V / 24 V), -15% / + 10%, 50/60 Hz	
Weight, approx. (kg)	0.6	0.5
Ambient temperature (°C)	Operating: 0...50; Transport / Storage: -25...+ 65	

Options / Supplements (only baelz 6497)	Remarks
2 inputs 0/4 ... 20 mA	
2 inputs 0/2 ... 10 V	
Calibration of measuring input PT100	for connection to Zener barriers

Notes (only baelz 6497):

- Also available in 115 V and 24 V.
- Wall-mounted housing: Order No. 3570-001
- Adapter for rail mounting: Order No. 3506-004

Inputs and outputs, baelz 6497 / 6597 (6X97 stands for both types)						
Type	Measuring inputs	Controller output	Digital inputs	Actual value output 0...10 V (PT100)	Alarm relay with potential-free changeover contact 250 V AC / 3 A.	with RS485 interface Modbus RTU
6497/2	2 measuring inputs can be assigned either with the process variable or the external setpoint: PT100, 0/2...10 V or 0/4...20 mA	Three-point step / three-point / two-point selectable	4x (OFS, open, close, stop)	1x 0...10 V (PT100)	1x	No
6597/1-S9			1x "Stop"	-	1x	No

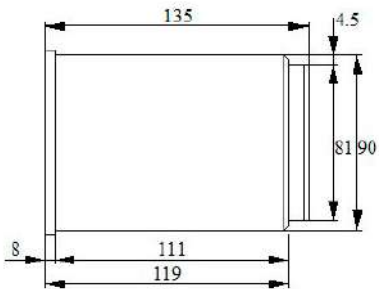

Housing dimensions baelz 6497

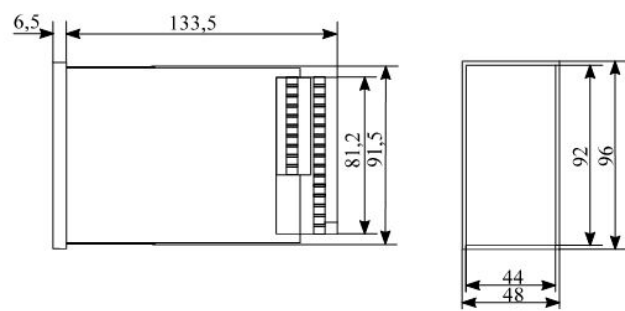

Housing dimensions baelz 6597

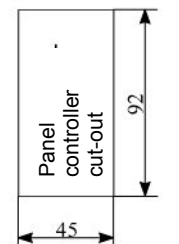
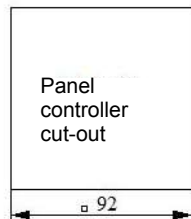

Connection diagram baelz 6x97

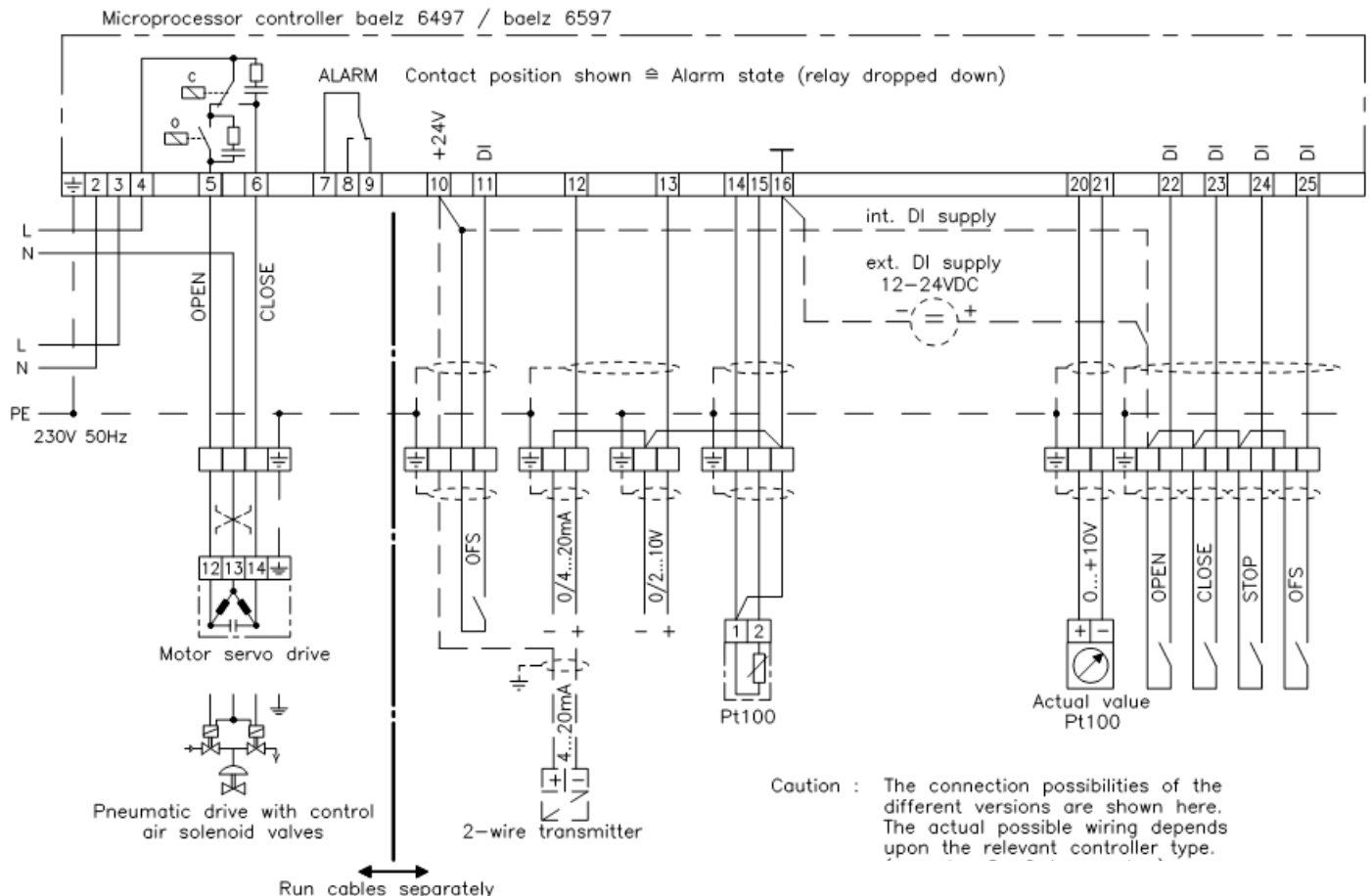

baelz 5195-SWI-5 5-port Ethernet switch

Supply voltage	18...30 V DC / 3 W
Dimensions WxHxD (approx., mm)	24 x 74 x 110

baelz 5277-2 RSS 422/485 repeater

suitable for bus lengths over approx. 1000 m and / or for more than approx. 30 bus users

for Modbus RTU

Mounting	on DIN 35 mm rail
Voltage	230 V AC, +15%...-10%, 48...62 Hz
Dimensions (mm)	55 x 100 x 128
Weight (approx., kg)	0.4

baelz 5280... Interface converter

RS 232 / RS485 converter as desktop device

Note: replacement for baelz 5275

RS 485 connection	Screw-type terminals
RS 232 connection	25-pin D-Sub socket incl. matching cable 3 m long for connection to PC (9-pin D-Sub connector)
Ambient temperature (°C)	5...50
Humidity	0...95% (non-condensing)
Configuration	5280-1 preconfigured for WINBAS 5280-2 preconfigured for INBAS
Voltage	115/230 V, +15%...-10%, 48...62 Hz
Dimensions WxHxD (mm)	161 x 53 x 139
Weight (approx., kg)	1.0

baelz 5280-TS Interface converter

RS 232 / RS485 converter - DIN rail mounting

RS 485 connection	Screw-type terminals
RS 232 connection	9-pin D-Sub socket incl. matching cable 3 m long for connection to WINBAS or INBAS PC (9-pin D-Sub connector)
Ambient temperature (°C)	5...50
Humidity	0...95% (non-condensing)
Configuration	5280-TS-1 preconfigured for WINBAS 5280-TS-2 preconfigured for INBAS
Voltage	230 V, +15%...-10%, 48...62 Hz
Dimensions WxHxD (mm)	55 x 100 x 128
Weight (approx., kg)	0.6

baelz 5280-MX-UPort interface converter

USB / serial converter with optical isolation	
RS 232- / 422- / 485 connection	9-pin D-Sub connector
USB	Type B
Ambient temperature (°C)	5...55
Humidity	0...95% (non-condensing)
including	1x screw terminal adapter 1x USB cable
Voltage	5 V DC / 260 mA from the USB
Dimensions WxHxD (mm)	52 x 80 x 22
Weight (approx., kg)	0.1

baelz 5279-BAC-5-RS4-... BACnet protocol converter

for BACnet / IP as server and Modbus RTU as master for max. 500 data points	
1x RJ45 10/100 MBit	for connection to BACnet/IP client
1x RS 485 on terminals	for connection to Modbus RTU slaves
LED-Anzeige	Power, status, RxD, TxD
Operating voltage	12...24 V AC/DC, max. 200 mA
Ambient temperature (°C)	
Humidity	20...80% RH, non-condensing
Mounting	DIN rail DIN EN 50022
Dimensions WxHxD (mm)	31 x 100 x 70
Weight (approx., kg)	0.3
5279-BAC-5-RS4-20	including preconfiguration ex-factory for max. 20 data points
5279-BAC-5-RS4-40	including preconfiguration ex-factory for max. 40 data points
5279-BAC-5-RS4-60	including preconfiguration ex-factory for max. 60 data points
5279-BAC-5-RS4-100	including preconfiguration ex-factory for max. 100 data points
MP5279-BAC-5-VK1	Supplement for preconfiguration of another data point ex-factory
PLEASE NOTE	Power supply unit Order No. 6208-021 must be ordered separately

baelz 5279-DP Protocol converter
for Profibus DP as slave and Modbus RTU as master; for max. 368 bytes of input and output data

1x RS 485 (D-Sub 9-pin), not galvanically isolated	for connection to Profibus DP master; max. 12 MBaud
1x RS 485	for connection to Modbus RTU slaves; max. 19.2 kBaud
Including 1x RS 485 connection cable 4 m	
LED-Anzeige	Communication, error
Operating voltage	18...30 V DC
Current consumption	max. 0.2 A at 24 V DC
Operating temperature (°C)	0..60
Ingress protection rating	IP 20
Mounting	DIN rail DIN EN 60715
Dimensions LxWxH (mm)	65 x 25 x 100
Weight (approx., kg)	0.3
5279-DP-40	including preconfiguration ex-factory for max. 40 variants
5279-DP-20	including preconfiguration ex-factory for max. 20 variants
5279-DP-10	including preconfiguration ex-factory for max. 10 variants
PLEASE NOTE	If there is no power supply for 24 V DC, Provide power supply unit Order No. 6208-021
	Configuration Profibus DP on site

baelz 5279-PNET protocol converter
for Profibus DP as slave and Modbus RTU as master; for max. 368 bytes of input and output data

1x RS 485 (D-Sub 9-pin), not galvanically isolated	for connection to PROFINET I/O controller 10/100 BASE-TX
1x RS 485	for connection to Modbus RTU slaves; max. 19.2 kBaud
Including 1x RS 485 connection cable 4 m	
LED-Anzeige	Communication, error
Operating voltage	18...30 V DC
Current consumption	max. 0.2 A at 24 V DC
Operating temperature (°C)	0..60
Ingress protection rating	IP 20
Mounting	DIN rail DIN EN 60715
Dimensions LxWxH (mm)	65 x 25 x 100
Weight (approx., kg)	0.3
5279-PNET-40	including preconfiguration ex-factory for max. 40 variants
5279-PNET-20	including preconfiguration ex-factory for max. 20 variants
5279-PNET-10	including preconfiguration ex-factory for max. 10 variants
PLEASE NOTE	If there is no power supply for 24 V DC, Provide power supply unit Order No. 6208-021
	Profinet configuration on-site

baelz 5279-BAC-2-TCP BACnet protocol converter	
for BACnet/IP as server and Modbus-TCP as client; for max. 200 data points	
1x RJ45 10/100 MBit via external Ethernet switch	for connection to BACnet/IP client and Modbus TCP
1x RS 485	on terminals
LED-Anzeige	Power, status, RxD, TxD
Operating voltage	12...24 V AC/DC, max. 200 mA
Ambient temperature (°C)	0...45
Humidity	20...80% RH non-condensing
Mounting	DIN rail DIN EN 50022
Dimensions WxHxD (mm)	31 x 100 x 70
Weight (approx., kg)	0.3
5279-BAC-2-TCP-20	including preconfiguration ex-factory for max. 20 data points
5279-BAC-2-TCP-40	including preconfiguration ex-factory for max. 40 data points
5279-BAC-2-TCP-60	including preconfiguration ex-factory for max. 60 data points
5279-BAC-2-TCP-100	including pre-configuration ex-factory for max. 100 data points
PLEASE NOTE	Power supply unit Order No. 6208-021 must be ordered separately
	5-way Ethernet switch, see Order No. 5195-SWI-5-001

baelz 5279-BAC-2-RS4 BACnet protocol converter	
for BACnet / IP as server and Modbus RTU as master for max. 200 data points	
1x RJ45 10/100 MBit	for connection to BACnet/IP client
1x RS 485	on terminals, for connection to Modbus RTU slaves
LED-Anzeige	Power, status, RxD, TxD
Operating voltage	12...24 V AC/DC, max. 200 mA
Ambient temperature (°C)	0...45
Humidity	20...80% RH non-condensing
Mounting	DIN rail DIN EN 50022
Dimensions WxHxD (mm)	31 x 100 x 70
Weight (approx., kg)	0.3
5279-BAC-2-RS4-20	including preconfiguration ex-factory for max. 20 data points
5279-BAC-2-RS4-40	including preconfiguration ex-factory for max. 40 data points
5279-BAC-2-RS4-60	including preconfiguration ex-factory for max. 60 data points
5279-BAC-2-RS4-100	including pre-configuration ex-factory for max. 100 data points
MP5279-BAC-2-VK1	Supplement for preconfiguration of another data point ex-factory
PLEASE NOTE	Power supply unit Order No. 6208-021 must be ordered separately

baelz 5279-EC-EC61330**Remote maintenance module without preconfiguration**

For remote maintenance of touch panel systems. Includes free connection software for configuration of VPN tunnel to industrial router. Ethernet TCP/IP

Configuration	by web server, FTP server or SD card (internet required)
Interfaces	1x to 4x LAN RJ45 Ethernet 10 / 100 MBit/s (fully configurable)
	0x to 3x WAN RJ45 Ethernet 10 / 100 MBit/s (fully configurable)
	USB 2.0 socket (max. 500 mA)
	SD card slot
Digital inputs	2; max. 24 V DC
Digital output	1; MOSFET, 200 mA
Temperature range (°C)	-25...+70°C
Humidity	10 to 95% RH, non-condensing
Supply voltage	12...24 V DC +/-20%
Power consumption max. (W)	4
Housing	metal
Dimensions WxHxD (mm)	43 x 108 x 99 mm
Mounting	DIN rail or wall-mounted with screw fixing system
Ingress protection rating	IP 20
Weight (approx., kg)	0.2
Certification	CE, UL, FCC

baelz 5279-EC-EC6133G**Remote maintenance module without preconfiguration**

For remote maintenance of touch panel systems. Includes free connection software for configuration of VPN tunnel to industrial router. Ethernet TCP/IP, 3G

Configuration	by web server, FTP server or SD card (internet required)
Interfaces	1x to 4x LAN RJ45 Ethernet 10 / 100 MBit/s (fully configurable)
	0x to 3x WAN RJ45 Ethernet 10 / 100 MBit/s (fully configurable)
	USB 2.0 socket (max. 500 mA)
	SD card slot
	LAN, 3G (wireless mobile) incl. antenna with 5 m cable
Digital inputs	2; max. 24 V DC
Digital output	1; MOSFET, 200 mA
Temperature range (°C)	-25...+70°C
Humidity	10 to 95% RH, non-condensing
Supply voltage	12...24 V DC +/-20%
Power consumption max. (W)	4
Housing	metal
Dimensions WxHxD (mm)	43 x 108 x 99 mm
Mounting	DIN rail or wall-mounted with screw fixing system
Ingress protection rating	IP 20
Weight (approx., kg)	0.2
Certification	CE, UL, FCC

baelz 5279-NB2 Remote maintenance module

for remote diagnosis, remote maintenance, remote evaluation and long-term data storage, reporting and user management as well as alarm management with e-mail / SMS notification

Plant schematic image	3
Overview	1
Data points / alarms	128
Recording buffer	50,000 values
Serial interface # 1	RS 232, DSUB
Serial interface # 2	RS 485, insulated, terminals
Ethernet	10/100 MBit/s, RJ45
Logs/protocols	Modbus-RTU/TCP
Digital inputs	2 isolated, max. 24V DC
1 relay	Max. 24V / 1A
4 analog inputs	0...10 V, 0...20 mA, max. 2x Pt100
Temperature range (°C)	-40...+65
Supply voltage	12...48 V DC
Power consumption max. (W)	4.5
Housing	Metal
Dimensions WxHxD (mm)	135 x 92 x 27
Ingress protection rating	IP 20
Weight (approx., kg)	0.5

EC310 **Process data transmission via the Internet**

EC350 **Process data transmission via Ethernet and mobile radio**

W **Installed in a wall housing with power supply**

Dimensions WxHxD (mm)	182 x 180 x 90
Cable glands	3 x M16 x 1,5
Ingress protection rating	IP 66
Ambient temperature (°C)	-25...+40
Max. humidity	50% RH at 40°C
Power supply 6208-021	100...230 V AC / 24 V DC (0.6 A)
including	<ul style="list-style-type: none"> • external SMA antenna with magnetic base • 10 m extension cable

2RK **Preconfiguration for max. 2 control loops, max. 16 trend and display variables; 1 plant schematic image (e.g. for baelz 6164, 7164, 64 / 65XX)**

4RK **Preconfiguration for max. 4 control loops, max. 32 trend and display variables; 2 plant schematic images (e.g. for baelz 6200, max 3 cards)**

8RK **Preconfiguration for max. 8 control loops, max. 64 trend and display variables; 3 plant schematic images (e.g. for baelz 6200, max 4 cards)**

Important instructions:

RS 485 preload S15 (supplement) required with baelz 6200 / 6XXX. Extension on-site or ex-factory possible.

To supply the remote maintenance module, a 24 V DC power supply is required, see Order No. 6208-021

For operation with GSM/GPRS, a SIM card with data terminal is required (on-site)

baelz 5279-NB2 (continued) Remote maintenance module

5279-NB2-EC310	Ethernet, without preconfiguration
5279-NB2-EC310-2RK	Ethernet, 2 circuits, 16 variables
5279-NB2-EC310-4RK	Ethernet, 4 circuits, 32 variables
5279-NB2-EC310-8RK	Ethernet, 8 circuits, 64 variables
5279-NB2-EC310-W	Ethernet, wall housing without preconfiguration
5279-NB2-EC310-W-2RK	Ethernet, wall housing, 2 circuits, 16 variables
5279-NB2-EC310-W-4RK	Ethernet, wall-mounted housing, 4 circuits, 32 variables
5279-NB2-EC310-W-8RK	Ethernet, wall housing, 8 circuits, 64 variables
5279-NB2-EC350	Ethernet/3G, without preconfiguration
5279-NB2-EC350-2RK	Ethernet/3G, 2 circuits, 16 variables
5279-NB2-EC350-4RK	Ethernet/3G, 4 circuits, 32 variables
5279-NB2-EC350-8RK	Ethernet/3G, 8 circuits, 64 variables
5279-NB2-EC350-W	Ethernet/3G, wall housing without preconfiguration
5279-NB2-EC350-W-2RK	Ethernet/3G, wall housing, 2 circuits, 16 variables
5279-NB2-EC350-W-4RK	Ethernet/3G, wall mount, 4 circuits, 32 variables
5279-NB2-EC350-W-8RK	Ethernet/3G, wall mount, 8 circuits, 64 variables
Accessories	
External quadband antenna	
ZB5279-NB2-SMA	Cable length 5 m, magnetic foot, SMA connection, weight, approx. 0.1 kg
Extension cable for GSM antenna (SMA connectors)	
ZB5279-NB2-L3m	Cable length 3 m, weight approx. 0.2 kg
ZB5279-NB2-L5m	Cable length 5 m, weight approx. 0.4 kg
ZB5279-NB2-L10m	Cable length 10 m, weight approx. 0.8 kg
Mounting set for DIN rail	
ZB5279-NB2-TS	Weight approx. 0.1 kg

baelz 452-N-1 Control unit

for steam heat transfer stations. Wall and panel control mounting with the following operating/display elements:

Selector switch	Open/close automatic
Signal lamp	Network (automatic position active)
Signal lamp	Automatic mode (automatic position active and circulating pump switched on)
Signal lamp	Drainage (DLE active: condensate valve is opened)
Signal lamp	Temperature monitor (condensate thermostat addressed, condensate valve closed)
Signal lamp	Fault (safety temperature limiter STB addressed)
Key/button	Test (hereby the safety temperature limiter can be simulated)
Ingress protection rating	IP 43
Supply voltage	230 V, 50 Hz
with built-in pre-fuse	2 A (medium-time lag)
Dimensions WxHxD (mm)	144 x 96 x 93
Weight (approx., kg)	0.8

baelz 455 Empty housing
for mounting baelz 1020. Wall mounting or mounting on actuator.

Housing / cover	Polycarbonate (RAL 7035)
Ingress protection rating	IP 66 / 67
Temperature (°C)	-40...+80
455-1	for baelz 1020 without power supply
455-3	for baelz 1020 with power supply
Dimensions LxWxH (approx., mm)	130 x 130 x 75
Weight (approx., kg)	0.4

Including mounting plate and TS 35 mounting rail and the required screws / cover screws

baelz 455-2 Empty housing
For mounting baelz 477, 456, 457, 462 and 465 relays. Wall mounting.

Housing	Polycarbonate (RAL 7035) with transparent cover, smoke gray
Ingress protection rating	IP 66 / 67
Temperature (°C)	-40...+80
Dimensions LxWxH (approx., mm)	130 x 130 x 125
Weight (approx., kg)	0.4

Including mounting plate and TS 35 mounting rail and the required screws / cover screws

baelz 455-3 Clock
Use e.g. for automatic sludge blowdown. For switch cabinet interior installation or fitting to a mounting rail.

Separately adjustable pulse and pause times; Time ranges from 0.05 sec to 300 h adjustable.

Output relay	2 changeover contacts 250 V / 3 A
Power supply	24...240 V, 50/60 Hz
Ingress protection rating	IP 20
Dimensions WxHxD (mm)	22,5 x 85 x 100
Weight (approx., kg)	0.14

baelz 465-KFA6 Contact protection and isolating relay
Use e.g. for automatic sludge blowdown. For switch cabinet interior installation or fitting to a mounting rail.

Separately adjustable pulse and pause times; Time ranges from 0.05 sec to 300 h adjustable.

Housing	plastic
Ingress protection rating	IP 20
Switching capacity	2 A, 250 V AC; Cos φ > 0,7
Weight (approx., kg)	0.15

2-channel

1 relay output with 1 changeover contact per channel

for EEx ia II C control circuits (control circuits in zone 0/1/2)

baelz 6205-B Transformer
EN 61558-2/6. For powering devices with 24 V operating voltage

Open design, stationary, for device installation and installation in dry rooms.

Strong foot angle piece for attachment. Screw connection with finger-proof leakage-current-proof transformer terminals.

Ingress protection rating	IP 00
Insulation class	T50/B
Max. ambient temperature (°C)	40
primary	230 V AC
secondary	24 V AC

baelz 6205-B...

Type	Power (VA)	Dimensions WxHxD (mm)	Weight (approx., kg)
6205-B-24/60VA	60	78 x 86 x 88	1.4
6205-B-24/100VA	100	85 x 91 x 102	2
6205-B-24/160VA	160	97 x 102 x 105	3
6205-B-24/250VA	250	97 x 102 x 119	3,6

baelz 6208/2-1,0A Power supply

With sieving and stabilized. Housing for DIN rail mounting.

Input voltage	230 V AC \pm 10%
Input fuse	internal
Output voltage	24 V DC
Residual ripple	max. 3%
Ingress protection rating	IP 20
Temperature range (°C)	-10...+40
Output current (A)	1.0
Dimensions WxHxD (mm)	90 x 115 x 78
Weight (approx., kg)	1.1

baelz 6208/3 Switching power supply

With LED operating display. Housing for DIN rail mounting.

Input voltage	85...264 V AC
Output voltage	24 V DC; 21.6 ... 26.4 V DC adjustable
Ingress protection rating	IP 20
Operating temperature (°C)	-10...+50
Operating humidity	20...90% RH, non-condensing

baelz 6208/3...

Type	Output current	Residual ripple	Dimensions WxHxD (mm)	Weight (approx., kg)
6208/3-0,63A	max. 0.63 A	150 mVp-p	25 x 93 x 56	0.2
6208/3-1,0A	max. 1.0 A	150 mVp-p	78 x 93 x 56	0.3
6208/3-2,0A	max. 2.0 A	480 mVp-p	78 x 93 x 67	0.4

baelz 6226-B Digital display instrument		
Panel front installation		
Display	4-digit LED	
Display height (mm)	10	
Housing	Plastic, black	
Ingress protection rating	IP 54	
Ambient temperature (°C)	+5...50	
Input signal	Pt100, 3-wire	
DC linear / scalable	mV, V, mA	
Thermocouples	J, K, T, E, N	
2 relay outputs	programmable e.g. min., max. alarms	
NO contact	1.5 A, 230 V AC (resistive load)	
Power consumption	approx. 3 VA	
Supply voltage	Type 6226-B-100...240VAC	100...240 V AC
	Type 6226-B-24VAC/DC	24 V AC/DC (±10%)
Dimensions WxHxD (mm)	48 x 48 x 110	
Weight (approx., kg)	0.3	

baelz 1049 Safety Zener barriers	
with ATEX approval Ex II (1/2) G [EEx ia/ib] II B / IIC. To maintain an intrinsically safe measuring circuit	
Mounting outside the hazardous area. i intrinsically safe ignition protection rating	
Operating temperature (°C)	-20...+60
Humidity	≤ 95% RH, no condensation
Housing material	Polyamide 6 fibreglas
Ingress protection rating	Housing: IP 40; Terminals: IP 20
Rail mounting, WxHxD (mm)	12.2 x 104 x 70
Weight (approx., kg)	0.1
1049-S11	Single barrier, positive
1049-S4	Single barrier, positive
1049-S5	Single barrier, alternating current
1049-S6	Double barrier, alternating current
1049-S1-red	Single barrier, positive
1049-S21	Double barrier, alternating current (for baelz 828-N-Ex)

Note:With NTC connection, the series resistance of the barriers is included in the measurement. Analog output 0/4 ... 20 mA z. e.g. to control the I/P converter baelz 86/IP8000. For other controllers on request.

Connection table arranged according to connection type		
Connection	Controller type	Zener barrier 1049 -...
Pt100	6X9X, 3659X, 6X9XA, 6X9XB, 6200, 6164, 6265, 5200, 6390	1 x S5, 1 x S6
NTC	6200, 6265, 6164	1 x S5, 1 x S6
	5200, 6390	1 x S5
Transmitters	6200, 6265, 6164	2 x S11
Actual value display	6X9X (from Pt100)	1 x S4
Analogue output 0/4 ... 20 mA	6200, 6X96, 6X87	1 x S4
Analogue output 0/2 ... 10 V	6200, 6164, 6X96, 6X87	1 x S4
Ext. setpoint potentiometer	229X, 23XX, 329XX	2 x 1049-S1 red

baelz 1049-T Isolating transformer
For intrinsically safe operation (EEx ia) IIC of baelz 88-Sp400/401-EEx positioner (with and without HART)
Ex II 3 (1) G Ex nA nC (ia Ga) IIC T4 Gc; Ex II (1) D (dEx ia Da) IIIC
Galvanic isolation between input, output and auxiliary energy supply

Analog output	0/4...20 mA
Auxiliary power supply	24 V DC
Voltage range	18...31.2 V
Input	0/4...20 mA
Ex i output	0/4...20 mA, max. load 0...800 Ω
Ambient temperature (°C)	-20...+70
Humidity	≤ 95% RH, no condensation
Housing material	Polyamide
Ingress protection rating	Housing: IP30; Terminals: IP 20
1049-T44	1 channel
1049-T45	2 channels
DIN rail mounting, WxHxD (mm)	99 x 122 x 17.6
Weight (approx., kg)	0.16

Note: Also for baelz 86/IP8000 split range

baelz 6260 Buffer amplifier
For galvanic isolation and conversion of analog signals (no galvanic isolation of the output signals)

For switch cabinet installation (DIN rail mounting)

Power supply	230 V, 50/60 Hz
Dimensions, WxHxD (mm)	48 x 72 x 94
Weight (approx., kg)	0.2

baelz 6260...			
6260-8.1-7.1	Input	0...10V	Ri = 200 kΩ
	Output 1	0...20 mA	(load 800 Ω)
	Output 2	0...10 V	(Imax = 20 mA)
6260-8.1-7.2	Input	0...10V	Ri = 200 kΩ
	Output 1	4...20mA	(load 800 Ω)
	Output 2	2...10V	(Imax = 20 mA)
6260-7.1-8.1	Input	0...20 mA	Ri = 50 kΩ
	Output 1	0...10V	(Imax = 20 mA)
	Output 2	0...20 mA	(load 800 Ω)
6260-7.2-8.1	Input	4...20mA	Ri = 50 kΩ
	Output 1	0...10V	(Imax = 20 mA)
	Output 2	0...20 mA	(load 800 Ω)
6260-8.1invertiert-7.1	Input	10...0 V	Ri = 1 MΩ
	Output 1	0...10V	(Imax = 20 mA)
	Output 2	0...20 mA	(load 800 Ω)
6260-8.1invertiert-7.2	Input	10...0V	Ri = 200 kΩ
	Output 1	2...10V	(Imax = 20 mA)
	Output 2	4...20mA	(load 800 Ω)

baelz 6261 Measuring amplifier			
For converting or amplifying analog signals (no galvanic isolation between input and output signals!)			
For switch cabinet interior installation (DIN rail mounting)			
Power supply	230 V, 50/60 Hz		
Dimensions, WxHxD (mm)	48 x 72 x 94		
Weight (approx., kg)	0.2		
baelz 6261...			
6261-8.1-7.1	Input	0...10V	Ri = 200 kΩ
	Output 1	0...20 mA	(load 800 Ω)
	Output 2	0...10 V	(Imax = 20 mA)
6261-8.1-7.2	Input	0...10V	Ri = 200 kΩ
	Output 1	4...20mA	(load 800 Ω)
	Output 2	2...10V	(Imax = 20 mA)
6261-7.1-8.1	Input	0...20 mA	Ri = 50 kΩ
	Output 1	0...10V	(Imax = 20 mA)
	Output 2	0...20 mA	(load 800 Ω)
6261-7.2-8.1	Input	4...20mA	Ri = 50 kΩ
	Output 1	0...10V	(Imax =20 mA)
	Output 2	0...20 mA	(load 800 Ω)
6261-4.2-7.2	Input	Potentiometer 5 kΩ	(3-wire)
	Output 1	4...20mA	(load 800 Ω)
	Output 2	2...10V	(Imax = 20 mA)
6261-PT100-7.2	Input	Pt100	(3-wire)
	Range	-100...+ 800 ° C, min. range 0...40°C. When ordering please specify range.	
	Output 1	4...20 mA	(load 800 Ω)
	Output 2	2...10 V	(Imax = 20 mA)

baelz 3502 Aluminium plate	
Suitable for baelz 164 and 6164	
for panel controller cut-out (mm)	187 x 187
Weight (approx., kg)	0.5
3502	Aluminum plate
3502-S	Aluminum plate with manual switch On-Off-Automatic-Off

baelz 3503 Aluminum plate	
For µCelsitron controller baelz 64XX	
with cutout (mm)	92 x 92
for panel controller cut-out (mm)	187 x 187
Adapter plate dimensions (mm)	192 x 192
Weight (approx., kg)	0.3

baelz 3504-1 Aluminum adapter plate		
Serves in conjunction with µCelsitron controller 64XX as replacement for controller insert baelz 2256 (white)		
Incl. 25 terminal blocks		
with cutout (mm)	92 x 92	
Adapter plate dimension (mm)	192 x 192	
baelz 3504-1...		
Type	Version	Weight (approx., kg)
3504-1	Aluminum adapter plate as listed	2.0
3504-1-M	including controller installation and wiring on terminal blocks (price without controller)	2.6

baelz 3505 Transparent door with lock

Ingress protection rating		IP 55	
baelz 3505...			
Type	für baelz-Type	Dimensions (mm)	Weight (approx., kg)
3505	µCelsitron controller 64XX	96 x 96 x 32	0.1
3505-1	6200-192-4	192 x 96 x 34	0.2
3505-2	6164/2	144 x 96 x 34	0.2

baelz 3506-C Adapter

Enables the switch cabinet interior installation of the controller listed below (fitting to a mounting rail)

for baelz types	64XX and 6164
Weight (approx., kg)	0.05

baelz 3508-3514 Aluminum adapter plate

For internal switch cabinet installation of a microprocessor controller baelz 6200-192-4 in Pilotronic magazine baelz 3514 (price without controller)

Dimensions (mm)	266 x 179
with cutout (mm)	186 x 92
Weight (approx., kg)	0.3

baelz 3508-3524 Aluminum adapter plate

For panel controller front mounting of a microprocessor controller baelz 6200-192-4 (price without controller) as a replacement for Pilotronic magazine baelz 3524-R

Dimensions (mm)	274 x 222
with cutout (mm)	186 x 92
Weight (approx., kg)	0.3

baelz 3570 / baelz 3572 Wall-mounted housing

For baelz 6200, 64XX and 2290

Hinge and quick assembly system, without screws. Opening is possible on both left and right sides and between each system part.

Terminal compartment with cable glands PG 13.5

Housing	plastic			
Ingress protection rating	IP 66			
baelz 3570... / baelz 3572...				
Type	for installation of	front cover	Dimensions WxHxD (mm)	Weight (approx., kg)
3570-FD-1,5	baelz 64XX, 2290	crystal clear, 4 x PG 13.5	176 x 237 x 224	1.55
3570-FR	1 card baelz 6200-B /-BAA. DENT-RS485	4 x PG 13.5	176 x 237 x 74	1.20
3570-FD-1.0+1.0	baelz 6200-192-4	crystal clear, 6 x PG 13.5	323 x 237 x 261	2.50

Connection is made with screw terminals on the back of the respective device. Delivery is built-in, unwired (prices without microprocessor controller). Front cover with cylinder lock, see supplements.

If the external peripherals are not connected with flexible cables, we recommend prewiring the controller (s), see supplement (below).

Supplements

MP3572-SHLO	Cylinder lock for front cover for housing 3570 ... 3572		
MP3572-V7	Pre-wiring of the controllers to DIN rail-mounted terminal blocks	7 terminal blocks	
MP3572-V14		14 terminal blocks	
MP3572-V14K		14 terminal blocks	including installation and wiring of a coupling relay.

Other versions on request.

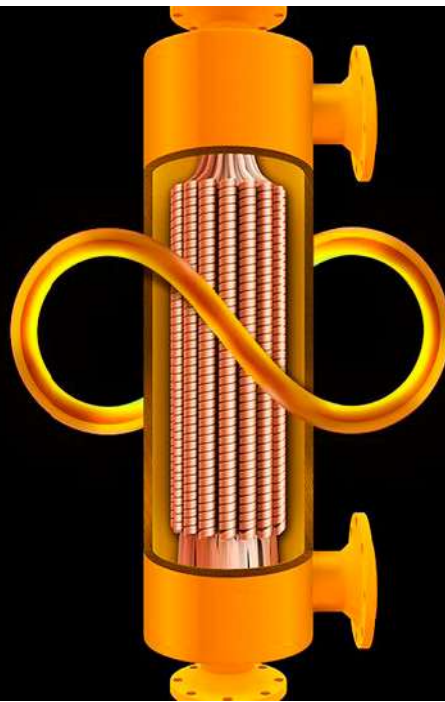

Baelz-thermodynamic®

Baelz offers heat exchangers for carrier fluids such as steam, condensate, hot and warm water.

A wide range, from conventional equipment to the world's only modular steam solution, is available for all types of HVAC, district heating and industrial installations.

As a manufacturer, we are able to offer custom solutions. Steam generators and coolers complete the program. For all types of heat exchanger we also offer pre-assembled compact stations.

Tube bundle materials are steel, copper and stainless steel. Appliances made entirely of stainless steel are also part of the delivery program. All steam-heated heat exchangers are operated with the proven condensate control system to ensure the greatest possible condensate cooling.

Note: For systems and stations with heat exchangers, see Chapter 6.1 "Steam and condensate - Baelz-thermodynamic®" starting on page 183 of this catalogue.



Inquiry form

page 166

baelz 105



U-tube heat exchanger

- in standing or lying version
- U-tube bundle exchangeable
- with feet
- standing version optional with tipping device
- PED 2014/68/EU compliant



page 167

baelz 106



Spiral-tube heat exchanger

- standing version
- exchangeable tube bundles optional
- Options: with feet / wall mounting / tipping device
- high elasticity for large temperature differences



page 170

baelz 111 / 112



Straight-tube heat exchanger

- standing version, thus suitable for capacity control with condensate backup
- ring channel optional
- compensator optional
- baelz 112 suitable for sanitary water



page 174

baelz 118



Condensate injection coolers

- for cooling high pressure condensate without risk of evaporation
- exchangeable tube bundles optional
- stainless steel 1.4571 tube bundles
- many design options



page 175

baelz 120



One-piece steam-heated source evaporator

- standing version
- with coiled tube bundle
- suitable for condensate control with forced condensate cooling
- with feet
- version without glands



page 176

baelz 122



U-tube evaporator, steam-heated

- horizontal version
- exchangeable U-tube bundle
- with support device
- with supporting cradles



page 177

baelz 128



Condensate tank

- angular design
- for unpressurized operation
- in steel or stainless steel
- with process connections
- without insulation



page 178

baelz 134



Stainless steel water tank

- standing version on base ring
- including removable insulation with polystyrene shell
- special sizes possible
- production according to DIN 4753, Part 1



page 179

baelz 135



U-tube heat exchanger

- horizontal version
- U-tube bundle exchangeable
- with feet



page 180

baelz 140



Plate heat exchanger

- in soldered or screwed version
- compact design
- innovative plate technology
- wide range of capacities



page 181

baelz 147



Module heat exchanger

- for modular transfer stations
- for hot water heating, sanitary water heating, cooling, production facilities, drinking water
- self-cleaning effect to counter deposits
- completely made of copper



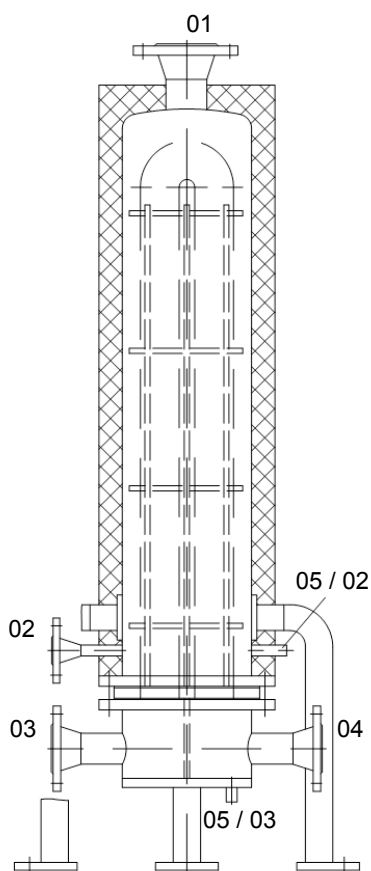

baelz 105 - standing version: tube side liquid; shell side steam

- 01 = heating steam inlet
- 02 = condensate outlet
- 03 = secondary return
- 04 = secondary flow
- 05/02 = Primary emptying (G 1/2 ")
- 05/03 = secondary emptying (G 1/2 ")

baelz 105

U-TUBE HEAT EXCHANGERS

- in standing or lying version
- U-tube bundle exchangeable
- with feet
- vertical version optional with tipping device

FLUIDS

standing version:

tube side fluids; shell side steam

horizontal version (optional):

tube side steam; Sheath side fluids

tube side fluids; shell side steam

tube side fluids; shell side fluids

Fluids: e.g. heating/sanitary water, glycol, hot oil, neutral liquids, other fluids on request.

To avoid corrosion in heat exchangers, water qualities must be checked and recorded at regular intervals.

Requirements for water qualities can be found in our Corrosion Specification, which we are happy to send you upon request.

Technical specifications, baelz 105

Tubes	Steel / copper / stainless steel
Tube sheet	Steel / plated / stainless steel
Preheader	Steel / stove enamelled / parts in contact with the fluid 1.4571
Shell	Steel
Insulation	Mineral wool with galvanized metal shell (50 / 80 mm)
Housing length	min. 1000 mm, max. 8000 mm
Diameter	min. Ø 114 mm, max. Ø 1200 mm

Design, production and testing according to Pressure Equipment Directive PED 2014/68/EU

Category / Module: I / A, II / A2, III / G or IV / G or Art. 4, para. 3 and AD 2000 Rules.

Note:

- In accordance with AD 2000 no load transfer may take place across flange and socket connections.
- For the horizontal version, a straight pipe must be provided on the inlet side as a calming section with a length of min. 6 x DN of the heat exchanger inlet nozzle. The nominal diameters of the pipe and heat exchanger inlet nozzles must match.
- Required hot water quality according to VDI 2035 (avoidance of damage in hot water heating systems according to DIN EN 12828)

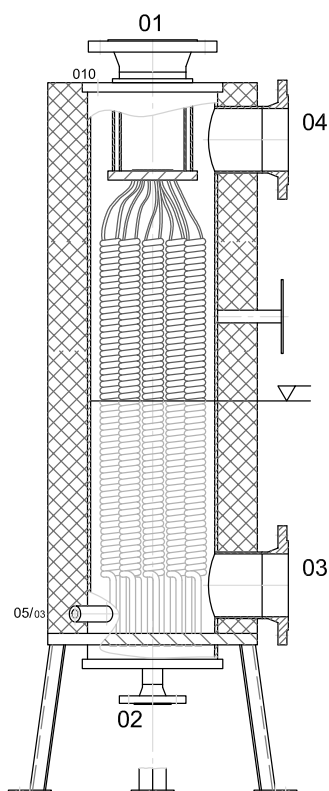

baelz 106

SPIRAL TUBE HEAT EXCHANGERS

- standing version, thus suitable for capacity control with condensate backup
- exchangeable tube bundles optional
- Options: with feet / wall mounting / tipping device
- high elasticity for large temperature differences
- version without glands

FLUIDS

Tube side inlet/outlet: steam/condensate
 Shell side: heating water / sanitary water / glycol

To avoid corrosion in heat exchangers, water qualities must be checked and recorded at regular intervals.
 Requirements for water qualities can be found in our Corrosion Specification, which we are happy to send you upon request.

Technical specifications, baelz 106

Tubes	Copper / stainless steel, tube bundles not exchangeable
Tube sheet	Carbon steel
Preheader	Carbon steel
Shell	Carbon steel
Condensate tray	Carbon steel, not removable
Insulation	Mineral wool with galvanized metal shell 80 mm
Housing height	max. 2200 mm
Diameter	min. Ø 89 mm, max. Ø 1000 mm

Design, production and testing according to Pressure Equipment Directive PED 2014/68/EU
Category / Module: I / A, II / A2, III / G or IV / G or Art. 4, para. 3 and AD 2000 Rules.

Supplements

removable condensate tray (B1) made of carbon steel
removable condensate tray (C1) made of carbon steel incl. 2 connections for thermo-level degassing (TNE)
exchangeable tube bundle (Fa)
"TURBO" version

baelz 106: tube side steam / condensate; shell side fluid

- 01 = steam inlet
- 02 = condensate outlet
- 03 = return inlet
- 04 = flow outlet
- 05/03 = secondary emptying (G 1/2 ")
- 010 = secondary deaeration/venting (G 1/4")

Note:

- In accordance with AD 2000 no load transfer may take place across flange and socket connections.
- On the inlet side, a straight pipeline must be provided as a calming section with a length of min. 6 x DN of the heat exchanger inlet nozzle. The nominal diameters of the pipe and heat exchanger inlet nozzles must match.
- Required hot water quality according to VDI 2035 (avoidance of damage in hot water heating systems according to DIN EN 12828)

Dimensions baelz 106

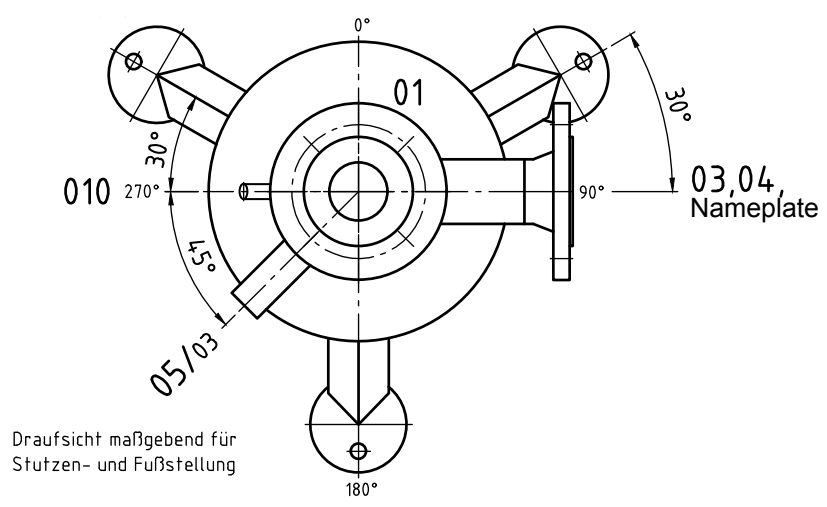
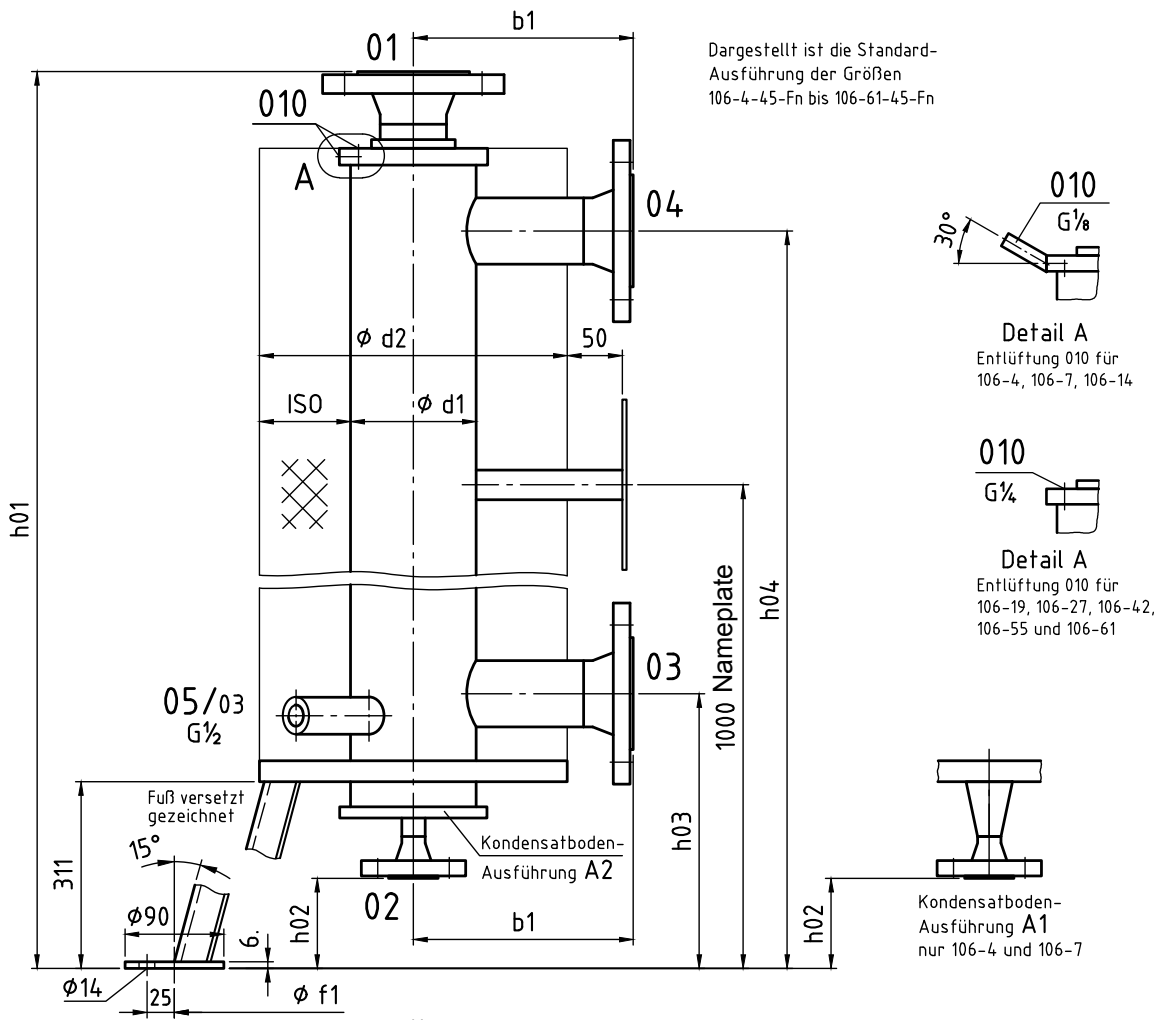

For dimensions and connections of all standard models, see the following page.

All dimensions are approximate and can change to suit project requirements!

Dimensions and specifications baelz 106 with tube length 4500 mm

All dimensions are approximate and can change to suit project requirements!

Dimensions baelz 106 standard models (in mm)								
Baelz Type	d1	d2	f1	b1	h01	h02	h03	h04
106-4	88.9	250	405	180	1551	197	384	1419
106-7	114.3	280	435	200	1556	197	391	1411
106-14	168.3	330	485	220	1561	206	398	1403
106-19	193.7	355	510	240	1563	197	408	1388
106-27	219.1	380	535	250	1581	196	418	1383
106-42	273.0	440	595	285	1581	186	436	1371
106-55	298.5	460	605	295	1581	181	441	1371
106-61	323.9	490	645	310	1581	181	441	1371

Connections, volumes and test pressures baelz 106 standard models									
Baelz Type	DN 01	DN 02	PN 01/02	DN 03/04	PN 03/04	tube side	shell side	tube side	shell side
						volume in liters	volume in liters	test press. in bar	test press. in bar
106-4	32	15	40	40	16-40	0.8	5.2	32.1	14.3
106-7	50	15	40	50	16	1.4	9	32.1	14.3
106-14	65	15	40	65*	16	3	20	31.8	14.3
106-19	65	15	40	80	16	5	23.7	31.8	14.3
106-27	100	25	40	100	16	6.5	34	31.7	14.3
106-42	125	32	40	125	16	9.9	54	31.7	14.3
106-55	125	32	40	125	16	17	52	31.7	14.3
106-61	125	32	40	125	16	12.5	78	31.7	14.3

All connections according to EN 1092-1 type 11, sealing surface form B1

* DN 65, PN 16 in 4-hole design

Note: For systems and stations with heat exchangers, see Chapter 6.1 "Steam and condensate - Baelz-thermodynamic®" starting on page 183 of this catalogue.



baelz 111 / 112

STRAIGHT-TUBE HEAT EXCHANGERS

- standing version, thus suitable for capacity control with condensate backup
- tube bundle not exchangeable
- ring channel optional
- compensator optional
- baelz 112 suitable for drinking water

FLUIDS

baelz 111:

Tube side heating water, glycol, hot oil, neutral liquids, other fluids on request; shell side steam and condensate

baelz 112:

Tube side drinking water; shell side steam and condensate

To avoid corrosion in heat exchangers, water qualities must be checked and recorded at regular intervals.

Requirements for water qualities can be found in our Corrosion Specification, which we are happy to send you upon request.

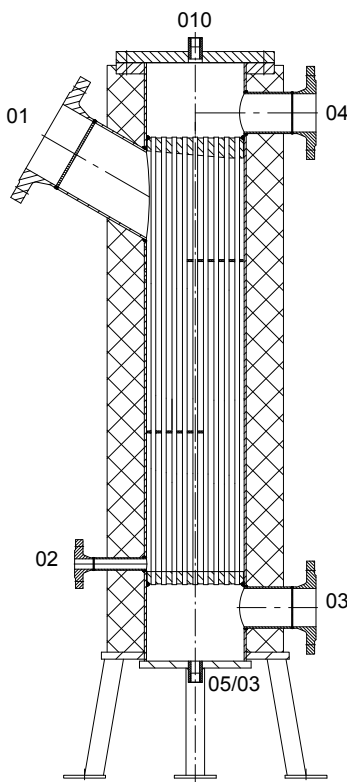

Technical specifications, baelz 111 / 112

	baelz 111	baelz 112
Tubes	Steel / copper / stainless steel	1.4571
Tube sheet	Steel / stainless steel	Steel (or Cu / rustfree steel plated / stainless steel)
Preheader	Steel / parts in contact with the fluid 1.4571	Stove-enamelled steel / stainless steel
Shell	Steel / parts in contact with the fluid 1.4571	Steel / parts in contact with the fluid 1.4571
Insulation	Mineral wool with galvanized metal shell 50 / 80 mm	
Housing height	min. 1000, max. 8000 mm	
Diameter	min. Ø 114 mm, max. Ø 1200 mm	

**Design, production and testing according to Pressure Equipment Directive PED 2014/68/EU
Category / Module: I / A, II / A2, III / G or IV / G or Art. 4, para. 3 and AD 2000 Rules.**

baelz 111 / 112:

- 01 = heating fluid inlet
- 02 = heating fluid outlet
- 03 = secondary return
- 04 = secondary flow
- 05/03 = secondary emptying (R 3/4 ")
- 010 = deaeration/venting for 01/02 (DN 20, PN 16)

Note:

- In accordance with AD 2000 no load transfer may take place across flange and socket connections.
- Required hot water quality according to VDI 2035 (avoidance of damage in hot water heating systems according to DIN EN 12828)

Dimensions baelz 111 / 112 - type 111-219-195-15 shown

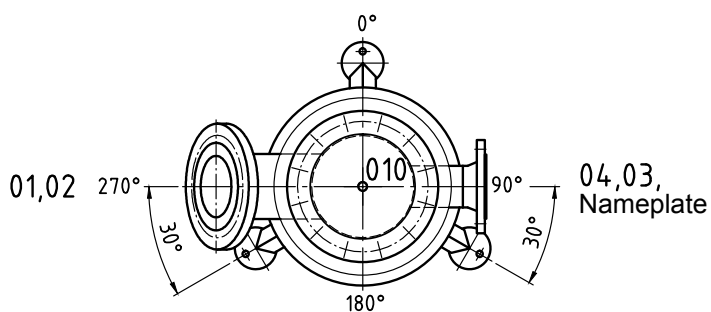
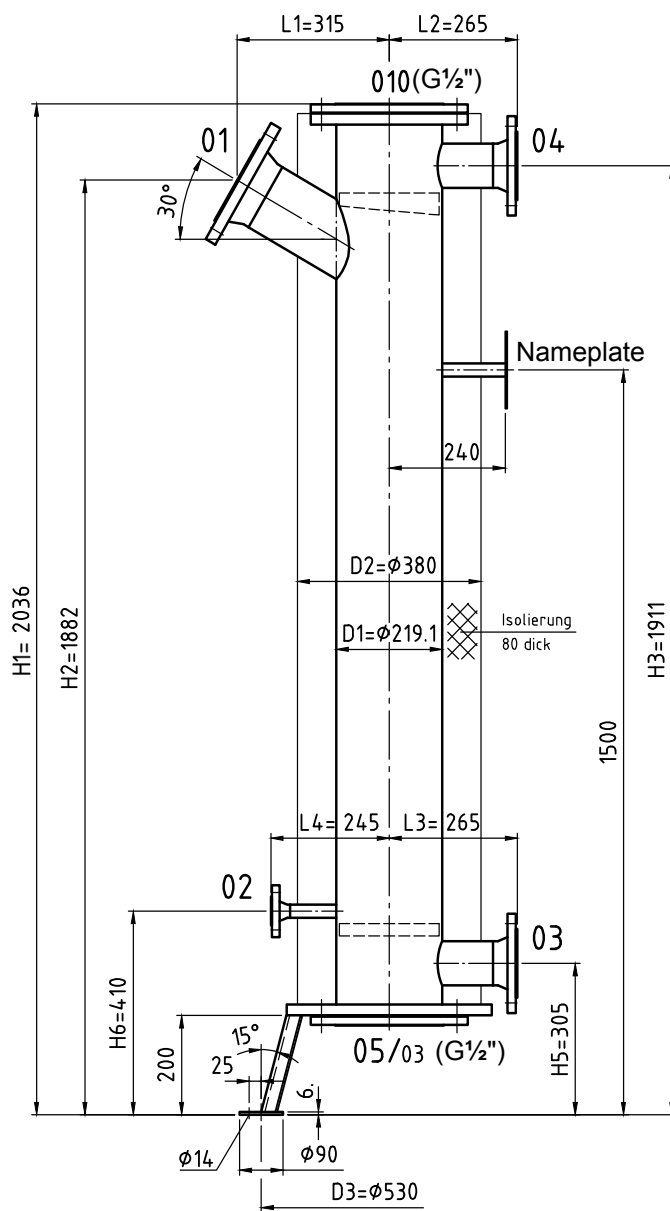

For dimensions and connections of all standard models, see the following page.

All dimensions are approximate and can change to suit project requirements!

Dimensions baelz 111 /112 with tube length 1500 mm

All dimensions are approximate and can change to suit project requirements!

Dimensions baelz 111 /112 standard models (in mm)												
Baelz Type	D1	D2	D3	H1	H2	H3	H5	H6	L1	L2	L3	L4
111-114-40-15	114,3	275	410	1976	1864	1866	290	375	230	190	190	185
111-139-60-15	139,7	300	435	2006	1872	1891	295	390	240	215	215	198
111-168-105-15	168,3	330	480	2006	1872	1891	295	395	280	233	233	220
111-219-195-15	219,1	380	530	2036	1882	1911	305	410	315	265	265	245
111-273-312-15	273,0	435	585	2106	1917	1961	325	447	340	295	295	270
111-324-448-15	323,9	485	655	2150	1929	1991	335	480	380	325	325	300

Connections baelz 111 /112 standard models									
Baelz Type	heating fluid inlet		condensate outlet		secondary inlet		secondary outlet		
	DN 01	PN 01	DN 02	PN 02	DN 03	PN 03	DN 04	PN 04	
111-114-40-15	65	40	15	40	50	16	50	16	
111-139-60-15	80	40	15	40	65*	16	65*	16	
111-168-105-15	100	40	20	40	65*	16	65*	16	
111-219-195-15	125	40	20	40	80	16	80	16	
111-273-312-15	125	40	25	40	100	16	100	16	
111-324-448-15	150	40	40	40	125	16	125	16	

All connections according to EN 1092-1 type 11, sealing surface form B1

* Connections 03 and 04 (DN 65, PN 16) in 4-hole design

Note: For systems and stations with heat exchangers, see Chapter 6.1 "Steam and condensate - Baelz-thermodynamic®" starting on page 183 of this catalogue.

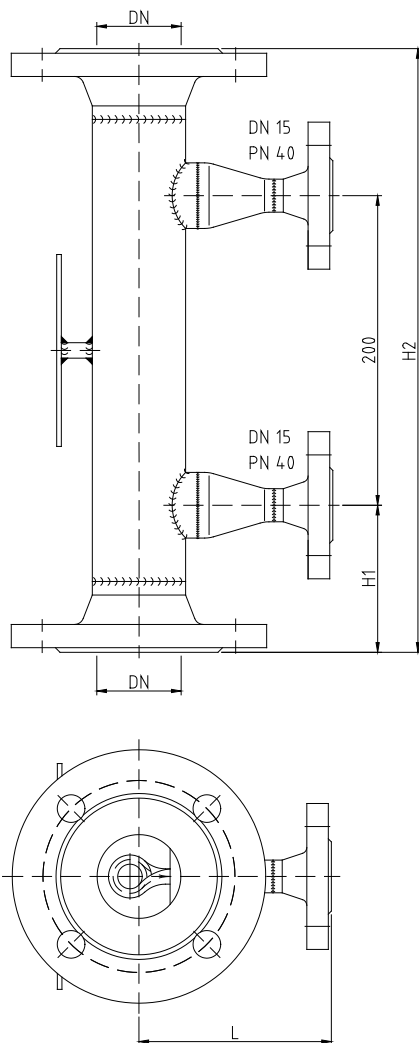

baelz 117

CONDENSATE COOLER

- For cooling of condensate from district heating steam supply
- Main application: Sub-stations with steam heat exchangers and without a condensate tank (closed steam system)
- Cooling spirals in stainless steel 1.4571, steel or copper
- Available in various design options

FLUIDS

Tube side: Ferndampfleitungskondensat
 Shell side: Cooling water

To avoid corrosion in heat exchangers, water qualities must be checked and recorded at regular intervals.
 Requirements for water qualities can be found in our Corrosion Specification, which we are happy to send you upon request.

Technical specifications, baelz 117

Tubes	Stainless steel 1.4571, steel or copper
Shell	Carbon steel
Insulation	Mineral wool with galvanized metal shell 80 mm
Height	min. 390 - max. 424 mm
Nominal diameters	DN 50 - DN 200
Speed of flow	max. 1.3 m/s (secondary side)

Design, production and testing according to Pressure Equipment Directive PED 2014/68/EU
Category / Module: I / A, II / A2, III / G or IV / G or Art. 4, para. 3 and AD 2000 Rules.

max. Temperature + max. Pressure shell / tube side

Shell / tube side	Nominal specifications	Temperature / Pressure
tube side (01/02)	DN 15, PN 40	max. 200 °C / 20 bar
shell side (03/04)	DN 50...200, PN 16	max. 110 °C / 10 bar

Dimensions, baelz 117

DN	L (mm)	H1 (mm)	H2 (mm)	cooling spirals	exchange surface area (m ²)
50	125	95	390	1 pass	0.03
65	133	95	390	1 pass	0.03
80	142	100	400	1 pass	0.03
100	163	102	404	2 passes	0.08
125	175	105	410	2 passes	0.08
150	189	105	410	2 passes	0.08
200	223	112	424	3 passes	0.15

Note:

- In accordance with AD 2000 no load transfer may take place across flange and socket connections.
- On the inlet side, a straight pipeline must be provided as a calming section with a length of min. 6 x DN of the heat exchanger inlet nozzle. The nominal diameters of the pipe and heat exchanger inlet nozzles must match.
- Required hot water quality according to VDI 2035 (avoidance of damage in hot water heating systems according to DIN EN 12828)

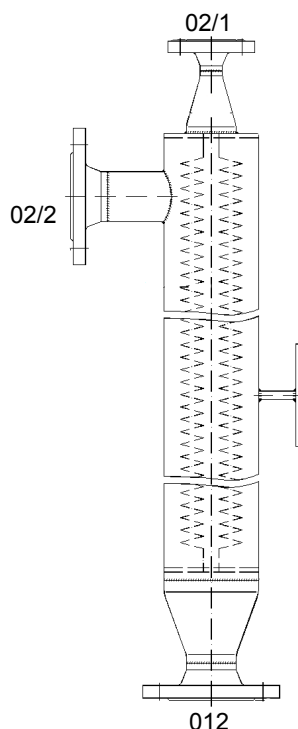

baelz 118

CONDENSATE INJECTION COOLERS (DESUPERHEATERS)

- for cooling high pressure condensate without risk of evaporation
- exchangeable tube bundles optional
- stainless steel 1.4571 tube bundles
- many design options

FLUIDS

Tube side: high pressure condensate
Shell side: cooled condensate stream

Continuous current flow: High pressure condensate through the tubes

To avoid corrosion in heat exchangers, water qualities must be checked and recorded at regular intervals.
Requirements for water qualities can be found in our Corrosion Specification, which we are happy to send you upon request.

Technical specifications, baelz 118

Tubes	1.4571, welded and rolled, not exchangeable
Shell	Carbon steel
Insulation	Mineral wool with galvanized metal shell 80 mm
Housing height	max. 2200 mm
Diameter	min. Ø 89 mm, max. Ø 1000 mm

Design, production and testing according to Pressure Equipment Directive PED 2014/68/EU
Category / Module: I / A, II / A2, III / G or IV / G or Art. 4, para. 3 and AD 2000 Rules.

Examples of max. temperature + max. pressure tube/shell sides

Nominal pressure	Max. temp (° C)	Max. pressure (bar g)
PN 16 / PN 16	250	11
PN 25 / PN 25	250	18
PN 40 / PN 40	250	28

Examples of mixing coolers

Version	baelz 118-S-8...	baelz 118-S-50...
Content (liters)	8	50
Flanged connection	DN 15 / 25	
Cooling coil + internal parts	1.4571	
Fluid	Steam and water	
Max. temp. / pressure	200°C / 11 bar	200°C / 10 bar
Process connections	Cooling water, draining, deaeration/venting	
Housing	Steel / stainless steel	
Weight (approx., kg)	15	100

baelz 118:

- 02/1 = high-temperature condensate to be cooled inlet
- 02/2 = cooled condensate inlet
- 012 = mixture of high-temperature condensate and cooled condensate outlet

Note:

- In accordance with AD 2000 no load transfer may take place across flange and socket connections.
- On the inlet side, a straight pipeline must be provided as a calming section with a length of min. 6 x DN of the heat exchanger inlet nozzle. The nominal diameters of the pipe and heat exchanger inlet nozzles must match.
- Required hot water quality according to VDI 2035 (avoidance of damage in hot water heating systems according to DIN EN 12828)

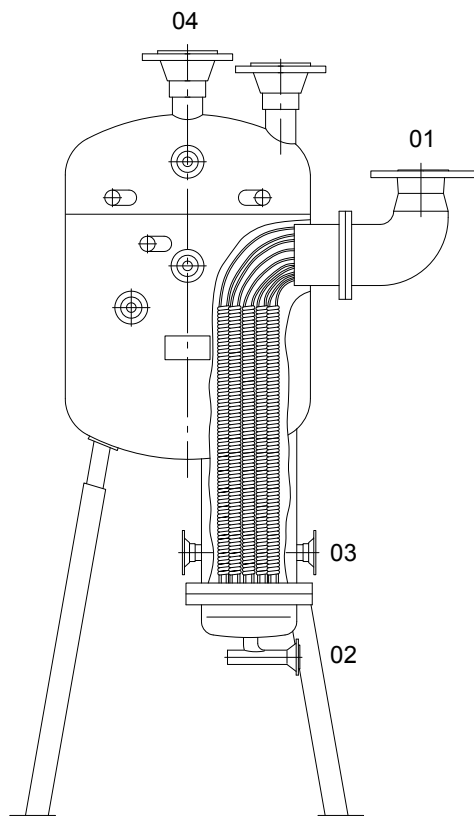

baelz 120

ONE-PIECE STEAM-HEATED SOURCE EVAPORATOR

- standing version
- with coiled tube bundle, optionally exchangeable
- suitable for condensate control with forced condensate cooling
- with feet
- version without glands

FLUIDS

Primary side: Steam through the tubes

Secondary side: Live steam around the tubes

To avoid corrosion in heat exchangers, water qualities must be checked and recorded at regular intervals. Requirements for water qualities can be found in our Corrosion Specification, which we are happy to send you upon request.

Technical specifications, baelz 120

Tubes	Steel / copper / stainless steel
Tube sheet	Steel / stainless steel
Preheader	Steel / stainless steel
Shell	Steel / stainless steel
Insulation	Mineral wool with galvanized / stainless steel sheet metal shell
Housing length	Housing dimensions are designed to order
Diameter	Housing dimensions are designed to order

**Design, production and testing according to Pressure Equipment Directive PED 2014/68/EU
Category / Module: I / A, II / A2, III / G or IV / G & AD 2000 Rules.**

baelz 120:

- 01 = steam inlet
- 02 = condensate outlet
- 03 = feedwater inlet
- 04 = live steam outlet

Note:

- In accordance with AD 2000 no load transfer may take place across flange and socket connections.
- On the inlet side, a straight pipeline must be provided as a calming section with a length of min. 6 x DN of the heat exchanger inlet nozzle. The nominal diameters of the pipe and heat exchanger inlet nozzles must match.
- Required hot water quality according to VDI 2035 (avoidance of damage in hot water heating systems according to DIN EN 12828)



baelz 122

U-TUBE EVAPORATOR, STEAM HEATED

- horizontal version
- exchangeable U-tube bundle
- with support device
- with supporting cradles

FLUIDS

Primary side: Steam through the tubes

Secondary side: Live steam around the tubes

To avoid corrosion in heat exchangers, water qualities must be checked and recorded at regular intervals.

Requirements for water qualities can be found in our Corrosion Specification, which we are happy to send you upon request.

Technical specifications, baelz 122

Tubes	Steel / copper / stainless steel
Tube sheet	Steel / stainless steel
Preheader	Steel / parts in contact with the fluid 1.4571
shell, flash tank	Steel / parts in contact with the fluid 1.4571
Insulation	Mineral wool with galvanized / stainless steel sheet metal shell
Housing length	Housing dimensions are designed to order
Diameter	Housing dimensions are designed to order

Design, production and testing according to Pressure Equipment Directive PED 2014/68/EU
 Category / Module: I / A, II / A2, III / G or IV / G & AD 2000 Rules.

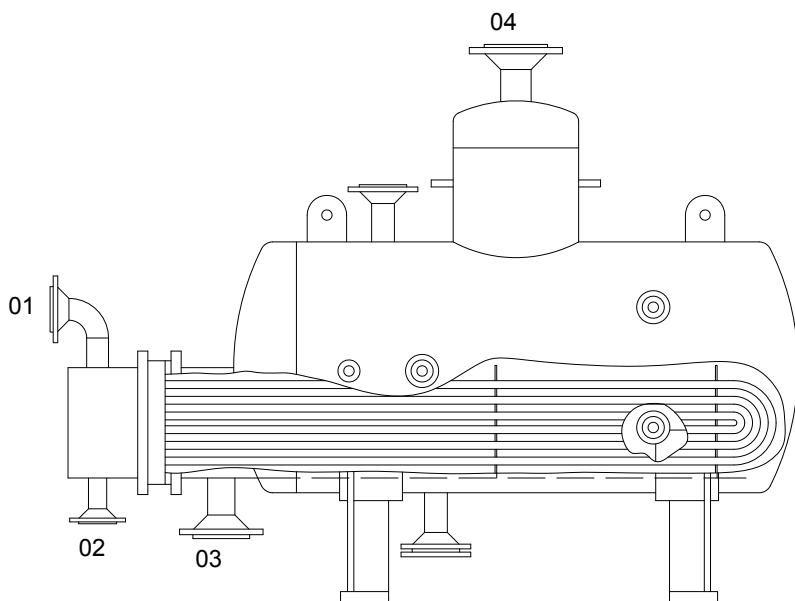

baelz 122:

- 01 = primary steam inlet
- 02 = primary condensate outlet
- 03 = feedwater inlet
- 04 = live steam outlet

Note:

- In accordance with AD 2000 no load transfer may take place across flange and socket connections.
- On the inlet side, a straight pipeline must be provided as a calming section with a length of min. 6 x DN of the heat exchanger inlet nozzle. The nominal diameters of the pipe and heat exchanger inlet nozzles must match.
- Required hot water quality according to VDI 2035 (avoidance of damage in hot water heating systems according to DIN EN 12828)



baelz 128 as part of a condensate terminal

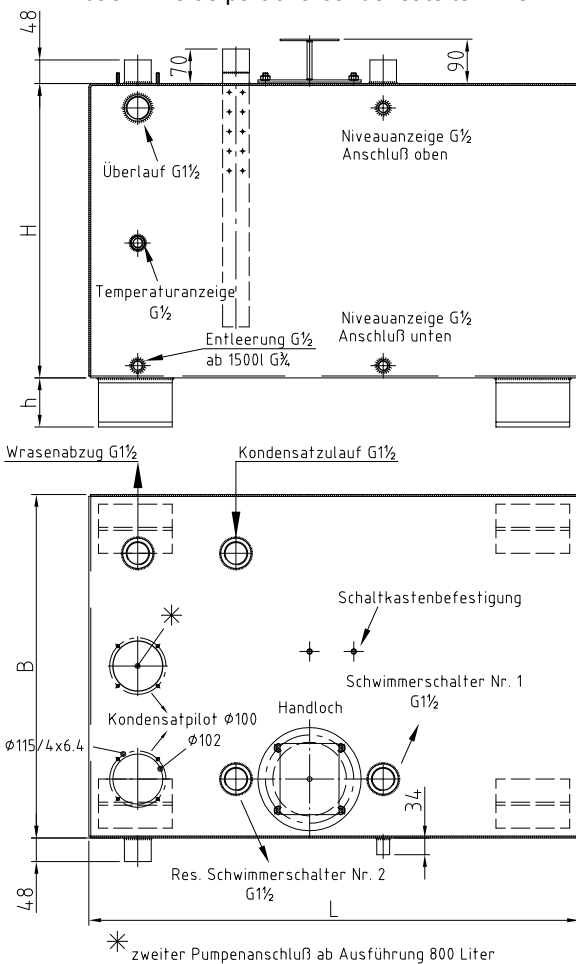

baelz 128

CONDENSATE TANK

- angular design
- for unpressurized operation
- in steel or stainless steel
- with process connections
- without insulation

PRODUCT DESCRIPTION

For the energy-efficient recycling of condensate as feed water or as a collection container for controlled water removal.

Including the required process connections for display and draining as well as for control and monitoring.

Ask Baelz about our pressurized condensate tank baelz 130 for a return feed low in oxygen and improved corrosion protection.

Technical specifications, baelz 128

Version	128-E	128-E-VA
Material	S235JR - 1.0037	X6CrNiMoTi17-12-2 -1.4571*
Interior surface treatment	raw	pickled and passivated
Exterior surface treatment	primed on untreated surface	pickled and passivated
Sheet thickness (mm)	4	
max. temperature (°C)	100	
Hand hole with cover	Ø150 mm	
Opening for pump	Ø105 mm	

Design, production and testing according to Pressure Equipment Directive PED 2014/68/EU, Art. 4, paragraph 3.

Supplements

- additional hand hole with cover and seal
- additional pump connection
- additional sleeve G 1
- additional sleeve G 1½

* for 2000 l. version, steel feet

baelz 128 dimensions and weights

	100	200	300	400	500	600	700	800	1500	2000
Capacity (l)	100	200	300	400	500	600	700	800	1500	2000
L (mm)	650	700	860	1000	1000	1200	1200	1340	1800	2000
B (mm)	380	500	600	700	850	850	1000	1000	1400	1700
H (mm)	600	600	600	600	600	600	600	600	600	600
h (mm)	90	90	100	100	100	100	100	100	100	100
Weight, approx. (kg)	51	79	102	127	144	162	180	202	336	367



baelz 134

STAINLESS STEEL WATER TANK

- standing version on base ring
- including 100 mm insulation with polystyrene shell silver, RAL 9006
- insulation meets Euro fire class B2 and is removable
- special sizes possible
- production according to DIN 4753, Part 1
- can be retrofitted with electric heating insert via inspection opening

FLUIDS

Industrial water tank baelz 134-TH: Water / water
Solar storage tank baelz 134-MU: Water / water
Warm water conditioner baelz 134-RU-D: Steam / water
Warm water conditioner baelz 134-RU-DK: Steam / water

Technical specifications, baelz 134-TH / baelz 134-MU

Total material	X6CrNiMoTi17-12-2 -1.4571	
Coil	max. 25 bar / 110°C	
Tank	max. 10 bar / 95°C	
Tank surface	pickled and passivated inside and out	
Connection	threaded connection	
Inspection opening	O120 mm with O-ring seal	
Energy efficiency	up to 500 l. class B; from 580 l. class C	
Applications	District heating, waste heat recovery, boiler	
	baelz 134-TH	baelz 134-MU
Version	with fixed stainless steel tube coil	with 2 fixed stainless steel tube coils
Capacity	min. 150 l, max. 1000 l	min. 300 l, max. 1000 l
Dimensions incl. insulation	min. Ø700 x 1105 mm, max. Ø1050 x 2080 mm	min. Ø700 x 1740 mm, max. Ø1050 x 2080 mm
Weight, approx.	min. 40 kg, max. 173 kg	min. 72 kg, max. 200 kg

Design, production and testing according to Pressure Equipment Directive PED 2014/68/EU

Technical specifications, baelz 134-RU-D / baelz 134-RU-DK

Materials	X6CrNiMoTi17-12-2 -1.4571; Union nut: malleable cast iron, galvanized; Seals: EPDM; Screws: 1.4541	
Coil	max. 13 bar / 200°C	
Tank	max. 10 bar / 95°C	
Tank surface	pickled and passivated inside and out	
Connections (standard)	Steam/condensate side: flange connection; Rest: threaded connection	
Inspection opening	O120 mm with O-ring seal	
Energy efficiency	up to 300 l class B; from 350 l class C	
	baelz 134-RU-D	baelz 134-RU-DK
Version	with fixed stainless steel tube coil	with 2 fixed stainless steel tube coils
Capacity	min. 150 l, max. 1000 l	min. 200 l, max. 1000 l
Dimensions incl. insulation	min. Ø700 x 1035 mm, max. Ø1050 x 2065 mm	min. Ø700 x 1410 mm, max. Ø1050 x 2065 mm
Weight, approx.	min. 44 kg, max. 195 kg	min. 67 kg, max. 215 kg

Design, production and testing according to Pressure Equipment Directive PED 2014/68/EU

Note:

- In accordance with AD 2000 no load transfer may take place across flange and socket connections.
- Required hot water quality according to VDI 2035 (avoidance of damage in hot water heating systems according to DIN EN 12828)



baelz 135 - version example.
Arrangement of connections individually selectable.

baelz 135

U-TUBE HEAT EXCHANGERS

- horizontal version
- U-tube bundle exchangeable
- with feet

FLUIDS

Tube / shell side: heating / sanitary water, glycol, hot oil, neutral liquids.

To avoid corrosion in heat exchangers, water qualities must be checked and recorded at regular intervals.

Requirements for water qualities can be found in our Corrosion Specification, which we are happy to send you upon request.

Technical specifications, baelz 135

Tubes	Steel / copper / stainless steel
Tube sheet	Steel / plated / stainless steel
Preheader	Steel / stove enamelled / parts in contact with the fluid 1.4571
Shell	Steel / parts in contact with the fluid 1.4571
Insulation	Mineral wool with galvanized metal shell (50 / 80 mm)
Housing length	min. 1000 mm, max. 8000 mm
Diameter	min. Ø 114 mm, max. Ø 1200 mm

Design, production and testing according to Pressure Equipment Directive PED 2014/68/EU
Category / Module: I / A, II / A2, III / G or IV / G or Art. 4, para. 3 and AD 2000 Rules.

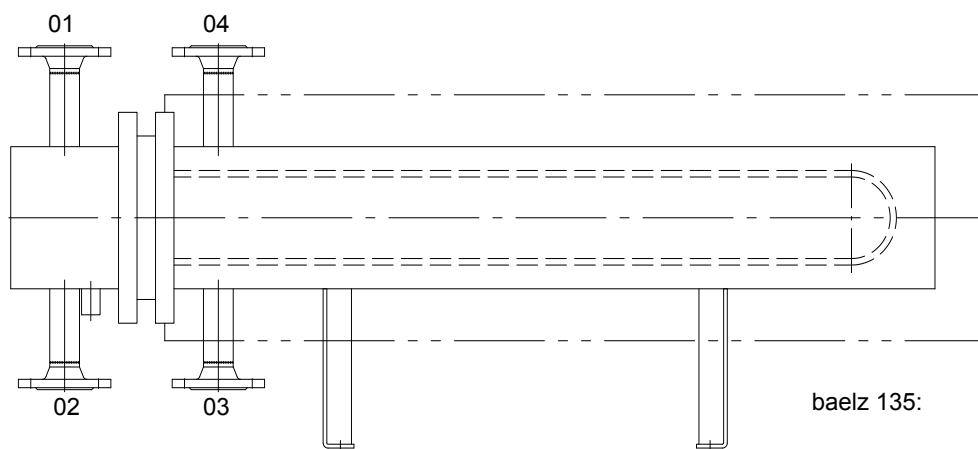

baelz 135:

- 01 = heating fluid inlet
- 02 = heating fluid outlet
- 03 = secondary return
- 04 = secondary flow

Note:

- In accordance with AD 2000 no load transfer may take place across flange and socket connections.
- On the inlet side, a straight pipeline must be provided as a calming section with a length of min. 6 x DN of the heat exchanger inlet nozzle. The nominal diameters of the pipe and heat exchanger inlet nozzles must match.
- Required hot water quality according to VDI 2035 (avoidance of damage in hot water heating systems according to DIN EN 12828)



baelz 140

PLATE HEAT EXCHANGERS

- in soldered or bolted version
- compact design
- innovative plate technology
- wide range of capacities
- suitable for drinking water

VERSIONS

baelz 140-10:

soldered version

plates: 1.4403 / 1.4404

solder: copper / nickel

baelz 140-20:

bolted version

plates: stainless steel / titanium

seal: NBR / EPDM / Viton

Note:

- In accordance with AD 2000 no load transfer may take place across flange and socket connections.
- Required hot water quality according to VDI 2035 (avoidance of damage in hot water heating systems according to DIN EN 12828)



baelz 147

MODULE HEAT EXCHANGERS

- for modular transfer stations
- for hot water heating, sanitary water heating, cooling, production facilities, drinking water
- self-cleaning effect inhibits deposits
- made entirely of copper

FLUIDS

Tube side 01/02: steam / water
Shell side 03/04: water
 baelz 147 heat exchangers are suitable for drinking water

Technical specifications, baelz 147

Material	Copper		
Insulation	optional, two-part insulation, weight approx. 2 kg (supplement)		
Connections tube side	for pipe Ø28, size DN 25	To connect a new FD-model to an existing transfer station, an adapter set no. ZB147-215 is necessary.	
Connections shell side	for pipe Ø42, size DN 40a		
Dimensions, approx.	Height approx. 900 mm, width approx. 450 mm		
Weight, approx.	20 kg		
	baelz 147-FD-2	baelz 147-O	baelz 147-HT
Tube side 01/02	200°C / 20 bar g	200°C / 20 bar g	250°C / 8 bar g
Shell side 03/04	150°C / 20 bar g	150°C / 20 bar g	150°C / 8 bar g
Design type	lateral fluid inlet	as 147, only steam inlet from above	lateral fluid inlet

baelz 147-FD-2 + 147-O: Design, manufacture and testing to Pressure Equipment Directive PED 2014/68/EU, Cat. I / Module A
baelz 147-HT: Design, manufacture and testing to Pressure Equipment Directive PED 2014/68/EU, Art. 4, paragraph 3

01 = heating fluid inlet 02 = heating fluid outlet
 03 = secondary return 04 = secondary outlet

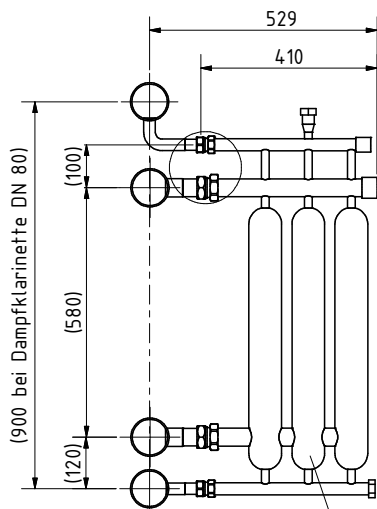

baelz 147-FD-2:

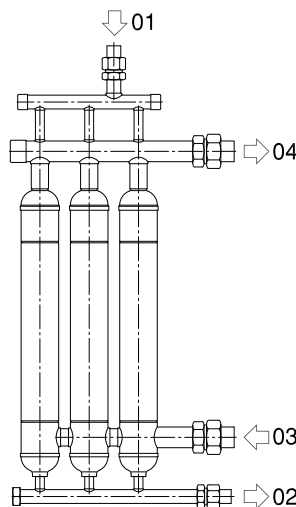

baelz 147-O:

baelz 147

Max. power per module (kW)	Fluid	Inlet (Tube side) (bar abs.)	Outlet (°C)	Pressure drop (bar)
45	Steam	1.5	75	0.15
81		2		0.37
126		3		0.6
170		4		0.82
201		5		0.92
210		6		0.84

baelz 147

Max. power per module (kW)	Fluid	Inlet / outlet (shell) (°C)	Pressure drop (bar)
45	water	70 / 90	0.01
81			0.03
126			0.08
170			0.15
201			0.2
210			0.22

Notes:

- As we are constantly improving our products, there is more than one series of this article. When ordering spares or parts for an existing system, please state the old serial numbers and, if in doubt, contact Baelz.
- In accordance with AD 2000 no load transfer may take place across flange and socket connections.
- Required hot water quality according to VDI 2035 (avoidance of damage in hot water heating systems according to DIN EN 12828)



Heat from steam, water or thermal oil

Want to save energy? Baelz offers solutions worldwide. With systems of all kinds and everything from a single source: consulting, design and engineering using our own proven components according to industrial standards and always in line with customer requirements.



An example showing how effective Baelz technology is: More than 4,000 steam heat transfer stations in the district heating network of Paris supply numerous buildings – from apartment buildings to ministries – with heat using the Baelz-thermodynamic® process, and have been doing so since the 1970s! In Germany too, numerous cities such as Dortmund, Frankfurt and Munich have steam district heating networks in which Baelz stations operate while saving energy.

Baelz offers a variety of processes and systems using water as a heat transfer medium in district heating, local heating and building heating networks. These include direct and indirect connection stations and heat transfer stations, as well as stations for drinking water heating. From apartment stations to heat transfer stations for hot water networks with 180°C and 32 bar, Baelz offers energy-efficient and holistic solutions.

Energy-efficient operation is the most important prerequisite of any system. The use of the proven Jetomat® ejectors based on the Baelz-hydrodynamic® process is the key to achieving this. The controlled ejector saves on energy and material, whether during distribution of heating water using only one main centrifugal pump or in the patented combination with plate heat exchangers.

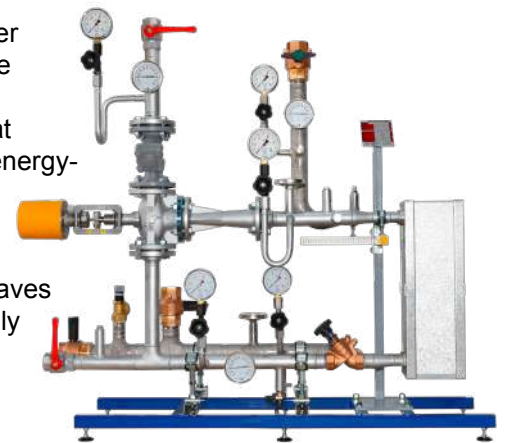

Thermal oil serves as a good alternative to steam or hot water operated systems. As a heat transfer medium, oil is especially well suited to indirect heating of larger industrial applications.

Generating cooling and heat with water

Absorption chillers are an environmentally friendly, energy-efficient and flexible technology for generating cooling or, if required, heat. Baelz offers three standard versions, all using the Baelz-absorpdynamic® process: Bee, Bumblebee and Hornet, named for their color and different sizes with outputs of 50, 160 and 500 kW respectively. These systems do not only stand out due to their compact and modern design, but above all thanks to their extremely low consumption of electrical energy, as they use heat to produce cooling.





**Steam and condensate – proven technology with a future
Baelz-thermodynamic®**

Optimal solutions are based on extensive consulting. Benefit from our years of experience and extensive knowledge of the applications in which our products are used. We will assist you in selecting the most suitable heat exchanger and fittings for the respective application. We are happy to support you in the design of individual components as well as of heat transfer stations or entire plants. The initial contact often arises from a desire to find ways to optimize processes. Disproportionately rising energy costs combined with an awareness for climate protection call for the use of our economical steam technology to optimize the energy efficiency of your plants.

Here are some of the fields of application of international Baelz customers

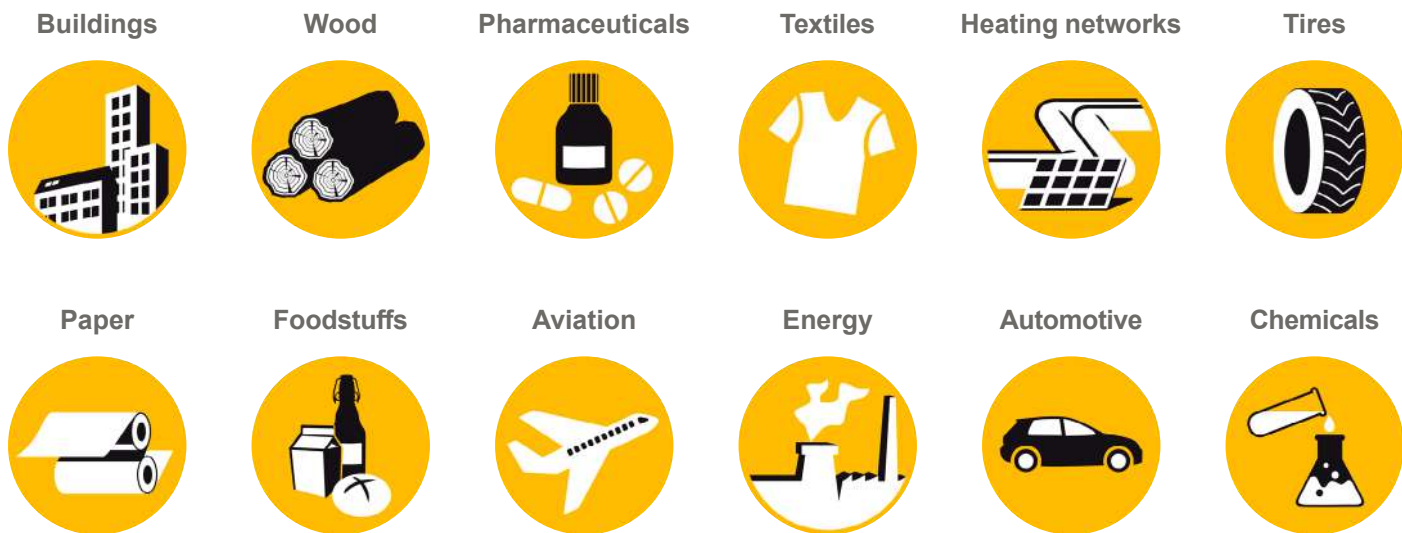

Progressive, reliable and economical for over 100 years

Our closed steam-condensate circuit guarantees energy efficiency, minimizes steam loss, offers high corrosion resistance and long reliable operation. Thanks to more than 100 years of experience and expertise gained since 1896, Baelz is the ideal partner for the highest demands in steam and condensate technology. Creating perfect and yet impressively simple solutions to problems in the field of process steam control and condensate technology remains at the heart of the company's objectives. Our goal is clear: To build absolutely reliable and efficient steam plants to guarantee customer satisfaction for many years to come. We develop practical solutions to optimize your steam system.

Energy-saving steam and condensate technology

The Baelz steam and condensate technology allows you to achieve energy savings of 5-25% for steam networks from 0.1 to 100 bar, even with superheated steam.

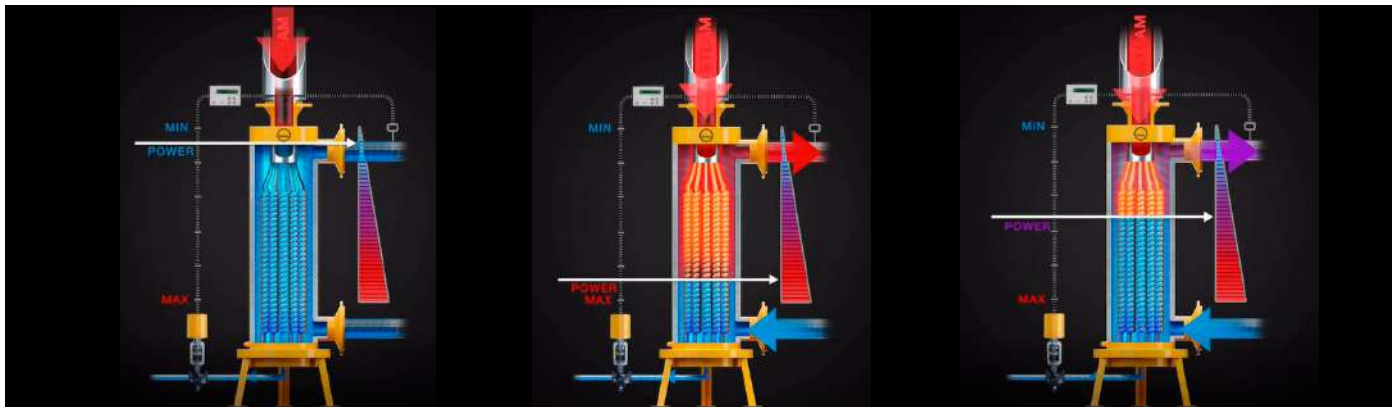

Examples of steam and condensate applications with Baelz:

- Replacement of horizontal shell-and-tube heat exchangers by vertical ones with condensate-side control and condensate re-cooling as single unit or compact station.
- Combination of your flash tanks and reuse of the resulting waste steam by means of a controlled steam ejector.
- Replacement of control valves by control steam ejectors for recirculation and recompression so as to achieve a performance increase of up to 15% in the heat consumer.
- Steam cooler for superheated steam to generate saturated steam while simultaneously reducing the pressure.
- Steam/water mixer for direct injection of steam into the water.
- Implementation of the closed steam and condensate cycle for a single system or an entire plant.
- Steam generators, also as clean steam generators or as a compact plant.

Whether you are planning to build a new steam plant or expand and improve your existing system, we can help you achieve your corporate objectives. Use Baelz experience to your advantage! Whether your goal is improved safety at work, energy savings, improved productivity, lower operating costs or reduced carbon dioxide generation, ask Baelz for a comprehensive professional consultation with no obligation.



Baelz condensate backup control



Steam transfer station; Palais Bourbon, Paris

Baelz - Your first choice for steam and condensate technology

This product catalogue gives you an overview of the wide range of Baelz products. Since our system solutions are usually designed according to individual requirements, many other components are also available for the optimization of your system - no matter whether you are planning a new installation or a retrofit project. From small ejectors to custom-engineered compact stations, from long-term availability of spare parts to systems which run reliably for decades - we want to save money and energy both with and for our customers.

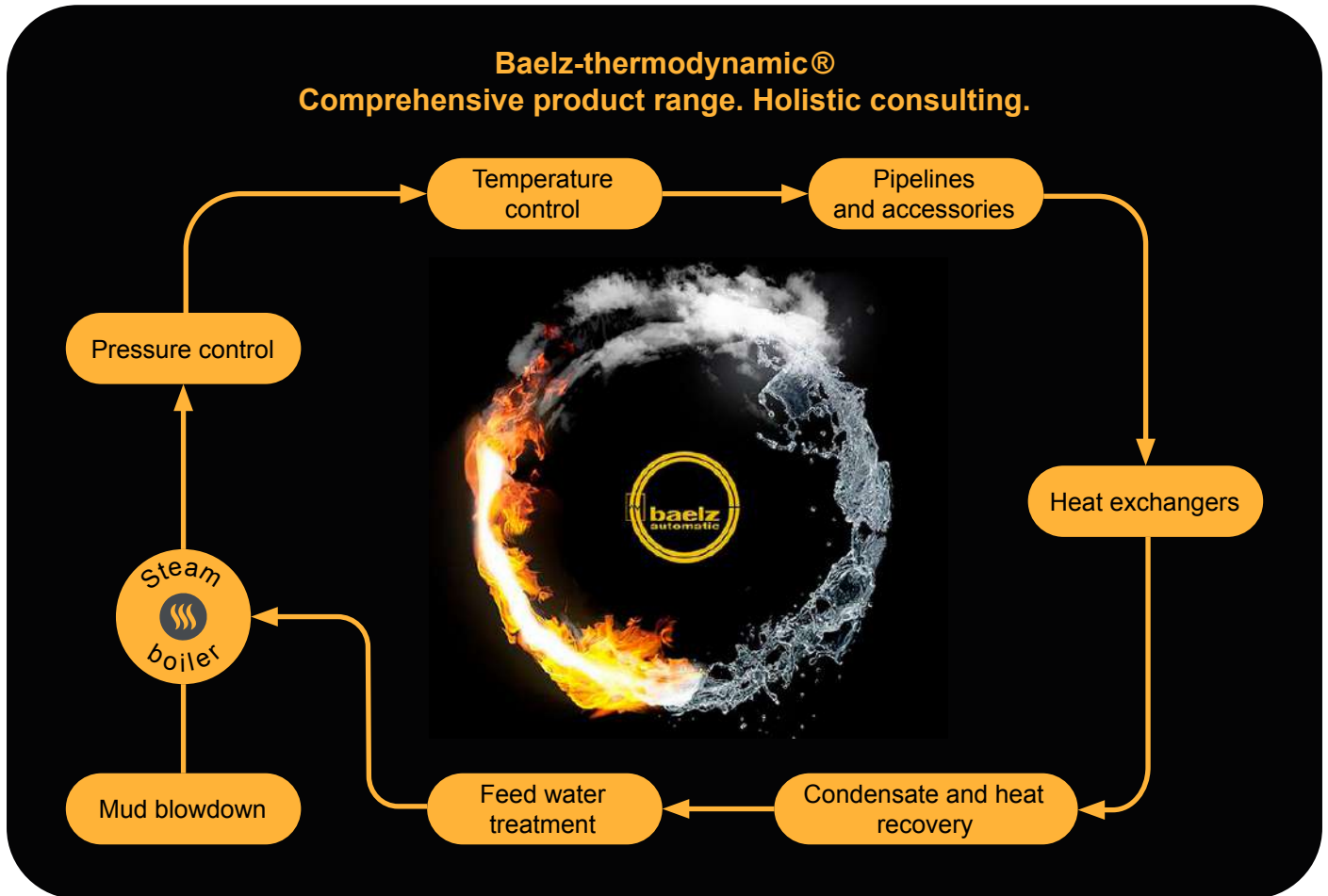

Baelz services

- Is my steam plant technology up-to-date?
- Does it comply with the current standards and norms?
- Where is there potential for optimization and savings?

Baelz offers individual audits to make your plant fit for the future.

For further information on services and training, as well as for inquiry forms and contact details:

 www.baelz.de

Selection tables for steam/water heat transfer stations

These tables allow you to select the right station for your needs based on the required heat output and the available pressure.

Heat output [kW]	150 kW				200 kW				300 kW				500 kW				
	1,5	3	6	10	1,5	3	6	10	1,5	3	6	10	1,5	3	6	10	
Steam pressure [barü]	20 (60/80°C)																
Secondary heating [K]	20 (60/80°C)																
Nominal connection widths	01 [DN]	40	32	32	25	50	40	32	25	65	40	40	32	80	65	50	40
Heat exchanger PN 25/10	02 [DN]	15	15	15	15	15	15	15	15	15	15	15	15	15	15	25	15
Pipe PN 16/10	03/04 [DN]	65	65	65	65	65	65	65	65	65	65	65	65	80	80	80	80
Heat exchanger raw material	Standard	VA				VA				VA				VA			
Number of condensate sections		1				1				1				1			
Length [mm]		2202	2172	2172	2202	2202	2279	2172	2172	2394	2279	2279	2172	2525	2549	2284	2284
Height [mm]		1990	2066	2066	2043	1990	2138	2066	2066	1885	2138	2138	2066	1968	2169	2138	2138
Width [mm]		708	600	600	600	708	606	600	600	738	606	606	600	798	839	686	606
Weight [kg]		350	370	380	360	350	430	380	370	450	440	450	380	540	560	470	440
Relevant dimensional drawing		1a	2a	2a	2a	1a	2a	2a	2a	1b	2b	2b	2b	1b	2b	2b	2b
As per order number (please cite with your enquiry)		DÜ_150_1a_1,5	DÜ_150_2a-3	DÜ_150_2a-6	DÜ_150_2a-10	DÜ_200_1a_1,5	DÜ_200_2a-3	DÜ_200_2a-6	DÜ_200_2a-10	DÜ_300_1b_1,5	DÜ_300_2b-3	DÜ_300_2b-6	DÜ_300_2b-10	DÜ_500_1b_1,5	DÜ_500_2b-3	DÜ_500_2b-6	DÜ_500_2b-10

Heat output [kW]	750 kW				1000 kW				1300 kW				1500 kW				2000 kW				
	1,5	3	6	10	1,5	3	6	10	1,5	3	6	10	1,5	3	6	10	1,5	3	6	10	
Steam pressure [barü]	20 (60/80°C)																				
Secondary heating [K]	20 (60/80°C)																				
Nominal connection widths	01 [DN]	80	65	50	100	80	65	100	80	65	100	80	65	125	80	65	125	100	80	80	
Heat exchanger PN 25/10	02 [DN]	25	25	25	25	25	25	25	25	25	25	25	25	32	25	25	32	25	25	40	
Pipe PN 16/10	03/04 [DN]	100	100	100	100	100	100	100	100	100	125	125	125	125	125	125	125	125	125	125	
Heat exchanger raw material	Standard	VA				VA				VA				VA				VA			
Number of condensate sections		2				2				2				2				2			
Length [mm]		2893	2576	2087	2963	2605	2427	2963	2605	2427	3079	2925	2750	3242	2938	2763	3242	2938	2763	3596	
Height [mm]		2788	2306	2306	2788	2306	2306	2788	2306	2306	2838	2843	2843	2838	2843	2843	2838	2843	2843	3013	
Width [mm]		875	839	789	875	803	839	875	803	839	930	875	875	930	875	875	930	875	875	930	
Weight [kg]		650	620	560	680	660	580	680	660	580	780	650	640	830	650	640	830	650	640	960	
Relevant dimensional drawing		3a	2c	2c	3a	2c	2c	3a	2c	2c	3a	3a	3a	3b	3b	3b	3b	3b	3b	3b	
As per order number (please cite with your enquiry)		DÜ_750-3a-3	DÜ_750-2c-6	DÜ_750-2c-10	DÜ_1000-3a-3	DÜ_1000-2c-6	DÜ_1000-2c-10	DÜ_1300-3a-3	DÜ_1300-3a-6	DÜ_1300-3a-10	DÜ_1500-3b-3	DÜ_1500-3b-6	DÜ_1500-3b-10	DÜ_2000-3b-3	DÜ_2000-3b-6	DÜ_2000-3b-10	DÜ_2000-3b-3	DÜ_2000-3b-6	DÜ_2000-3b-10	DÜ_2000-3b-10	

The components of the stations are also available separately and can be found in this catalogue.

[Inquiry form](#)

Steam Terminal®

STEAM HEAT TRANSFER COMPACT STATIONS

Our ready-to-install, fully piped, wired and tested steam heat transfer stations, designed on the basis of our vertical condensate-side controlled heat exchangers, guarantee optimum control quality, a high energy transfer rate and a long service life.

Simple solutions for complex, customer-specific tasks; with over 100 years of Baelz steam experience.

ADVANTAGES AT A GLANCE

- Enthalpy flow equilibrium in steam, hot water, thermal oil and warm water for building and process heat.
- Fully automatic heat transfer stations with patented Baelz technology: Baelz-thermodynamic®, Baelz-vapordynamic®, Baelz-hydrodynamic®, Baelz-electrodyn®.
- Fully pre-assembled as a steam terminal, hot water terminal or thermal oil terminal.
- Can be transported with a pallet truck. No packaging required for storage and transport.



Steam Terminal® up to 2000 kW with a baelz 106 spiral tube heat exchanger (above photo, below typical system layout)

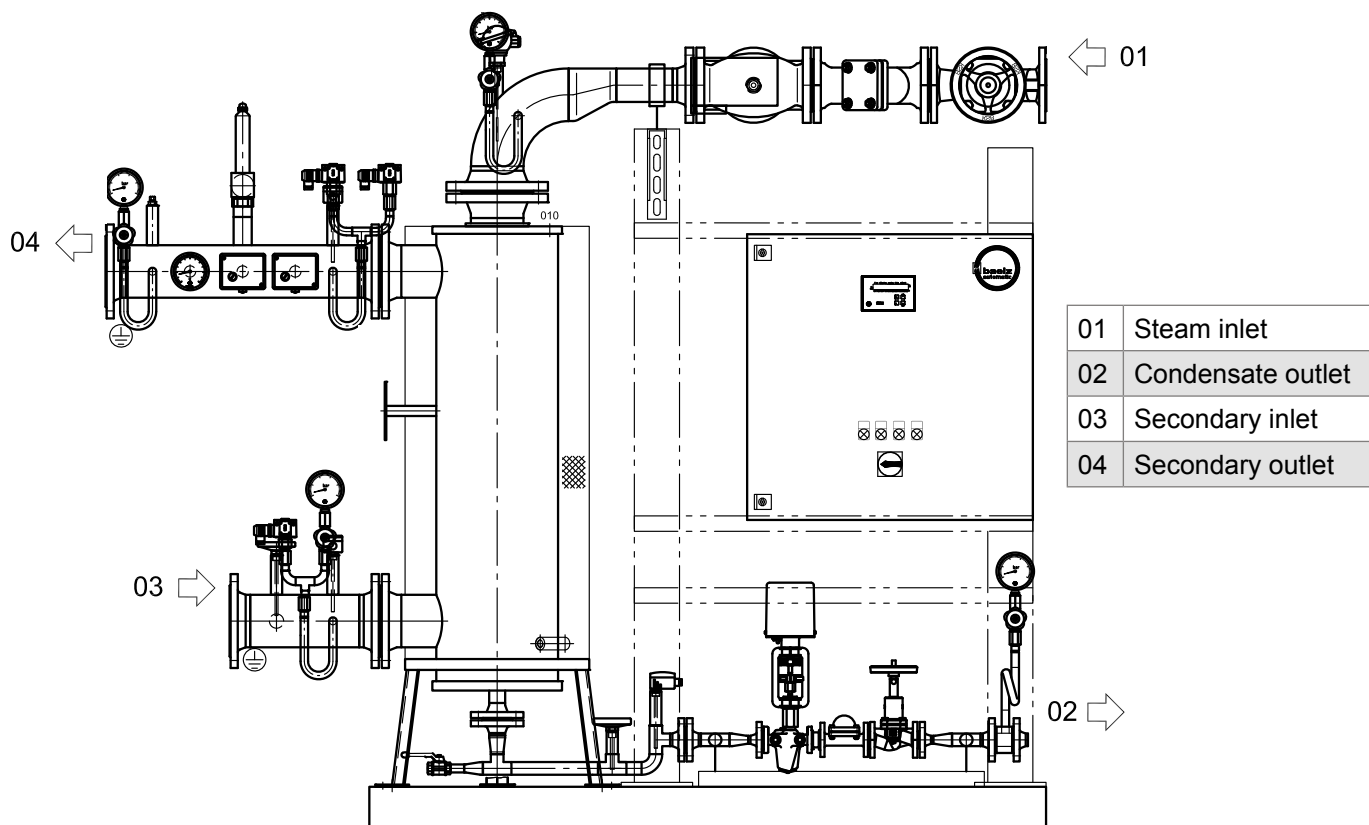



Closed steam heat transfer stations installed for an international stainless steel manufacturer

Individual heat transfer station

CUSTOMIZED STEAM HEAT TRANSFER STATIONS

Baelz also engineers larger steam heat transfer stations according to individual requirements and installs them on site. The closed steam condensate system prevents excess steam from being wasted. Its energy is preserved and is available for further use after conversion into hot water. The system runs quietly, saves energy and minimises wear on materials. Wear and corrosion due to atmospheric oxygen in condensate lines are a thing of the past. Energy and therefore financial savings ensure that an investment in a closed steam condensate system is amortized within a very short time.

ADVANTAGES AT A GLANCE

- Energy saving through use of excess steam
- Low noise and wear: no steam hammer
- Durable: corrosion and wear are minimized
- You benefit from Baelz' long experience in the design and control of complex systems
- Quick amortization through saving of expensive steam energy

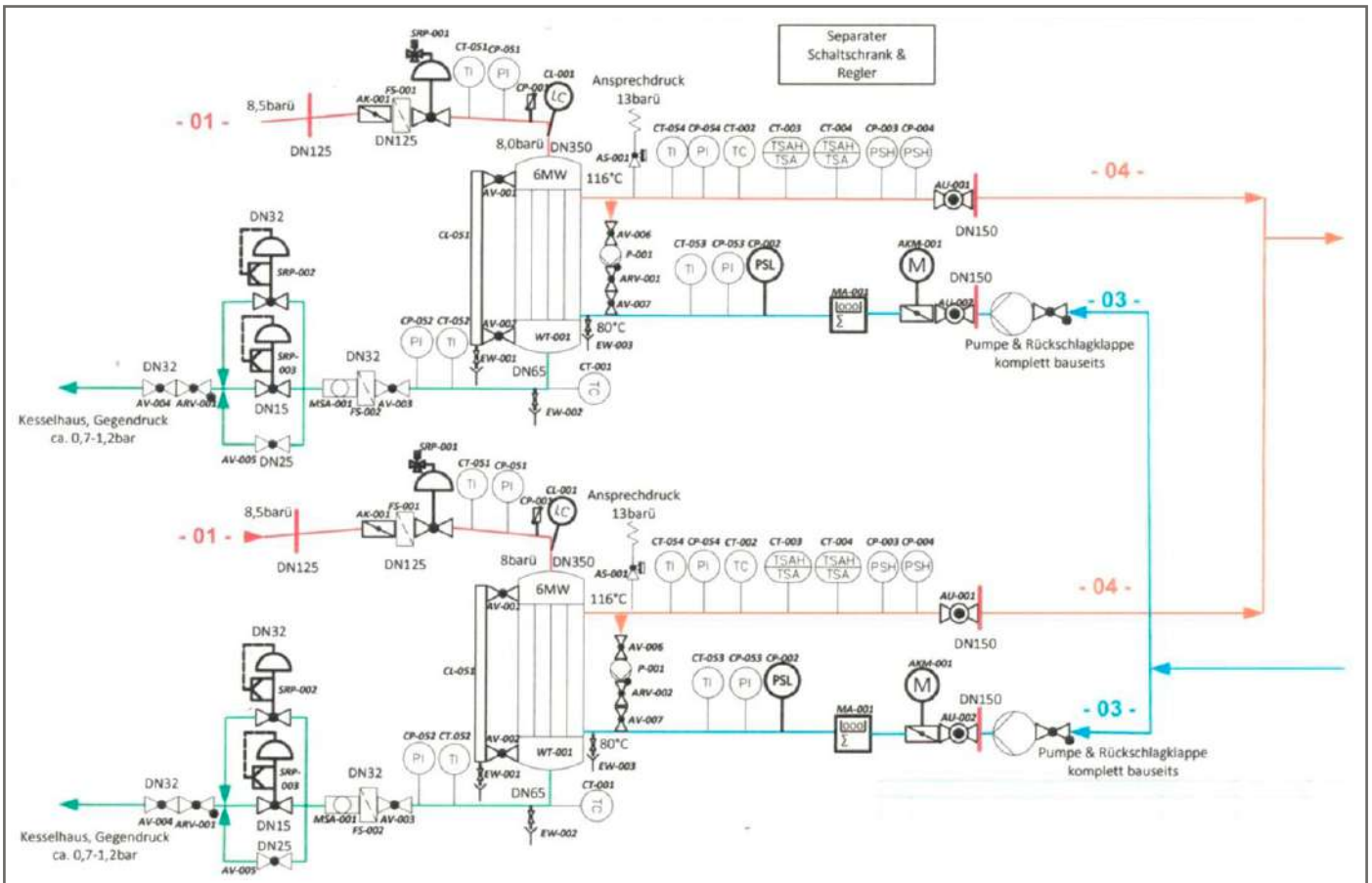

Example of a hydraulic plan of a closed steam condensate system

[Inquiry form](#)

Steam Terminal® Modulo

MODULAR STEAM HEAT TRANSFER COMPACT STATIONS

Our ready-to-install, fully piped, wired and tested steam/water compact stations, designed on the basis of our modular heat exchangers, guarantee optimum control quality, a high energy transfer rate and a long service life. The Modulo heat exchangers, baelz 147 and baelz 150, each consist of only one material - copper or stainless steel - and can therefore be completely and easily recycled and replaced.

ADVANTAGES AT A GLANCE

- Fully automatic heat transfer station.
- Exchangeable standard modules for economical installation and running.
- Improved safety in the heat supply.
- Entirely recyclable.
- Fully pre-assembled as a steam terminal, hot water terminal or thermal oil terminal.
- Can be transported with a pallet truck. No packaging required for storage and transport.



Steam Terminal® Modulo with reserve connection for another baelz 147 heat exchanger

01	Steam inlet
02	Condensate outlet
03	Secondary inlet
04	Secondary outlet

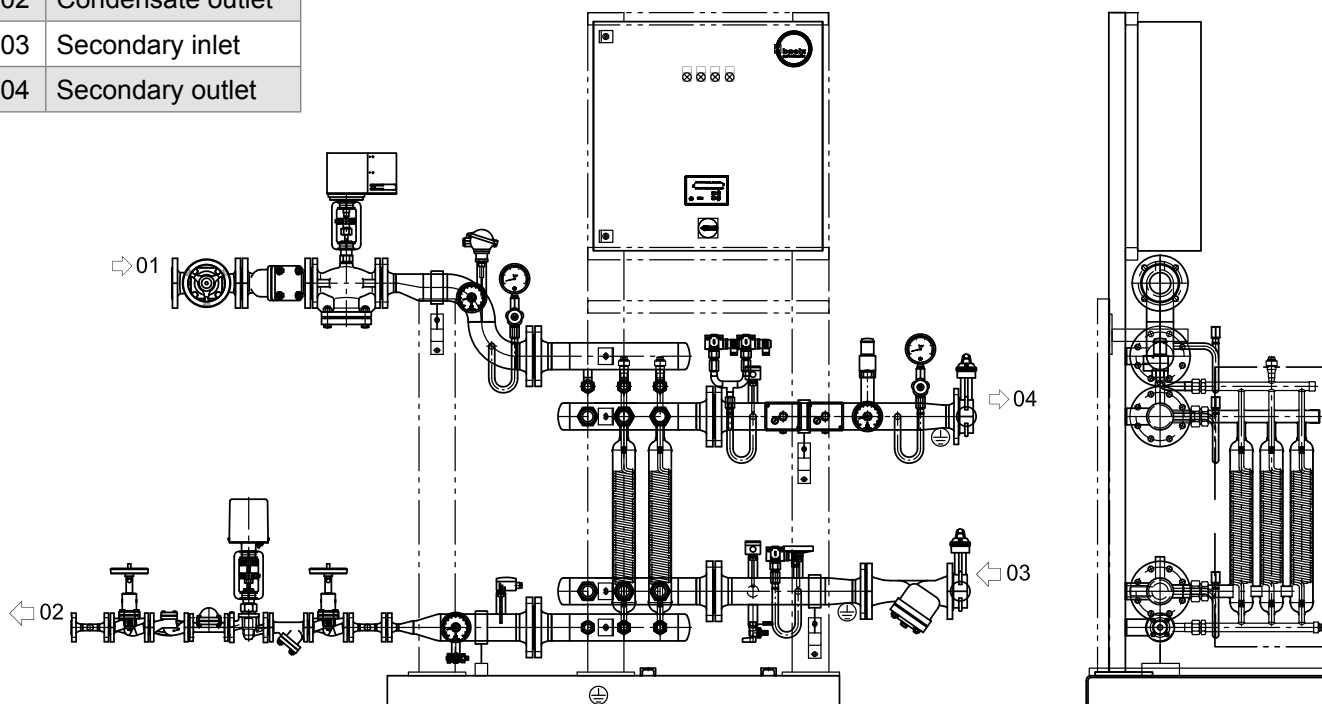



Clean steam generator compact station with baelz 120 in upright configuration with condensate-side control (above photo, below typical schematic diagram)

Design, manufacture and testing of the evaporators according to the Pressure Equipment Directive PED 2014/68/EU, category/ module: I/A, II/2, III/G or IV/G & AD 2000 regulation.

Baelz offers a wide range of steam generation systems: Horizontal with steam side control and upright with condensate side control. The upright designs in one or two parts have the advantage of taking up considerably less floor space. In addition, the upright design makes for significantly lower condensate backup times and higher condensate cooling. Automatic functions for level, pressure, conductivity and blowdown are always integrated and fully wired and tested.

Steam Terminal® steam generation

CLEAN STEAM GENERATOR COMPACT STATIONS

The clean steam generator is fed with primary steam from an external source. It produces clean steam from demineralized water. Cross-contamination cannot occur because the primary circuit is fed by the steam boiler and the secondary circuit by the clean steam generator. The stations can be used for all sterilization systems in industry, sterilization processes with autoclaves in the medical sector, in the food and dairy industry as well as for air humidification.

ADVANTAGES AT A GLANCE

- Fully pre-assembled and skid-mounted for easy assembly and transport.
- Thermally insulated on request.
- Made of passivated stainless steel 1.4571 for corrosion protection and durability
- Live steam capacities and pressures can be selected as required
- Station is supplied complete with control cabinet and is equipped with automatic level control, pressure control, conductivity control, automatic blowdown.
- Also available as individual components for assembly on site.
- Available in upright configuration with condensate side control or in horizontal configuration with steam side control.

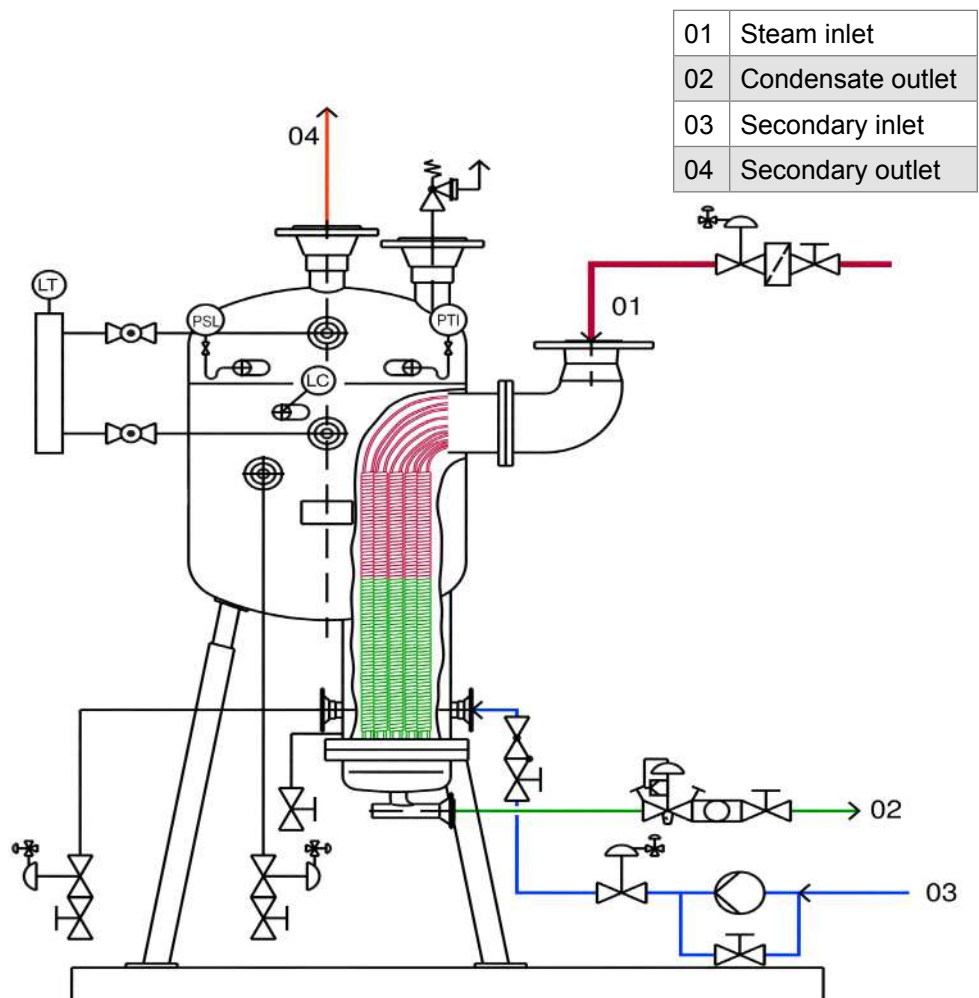



- CLEAN STEAM GENERATOR COMPACT STATIONS IN HORIZONTAL CONFIGURATION**
- In horizontal configuration with steam side control
 - Model with dome for favorable flow conditions
 - With condensate tank baelz 128
 - Better energy utilization with re-cooling and feed water preheating

Clean steam generator compact station with baelz 122 in horizontal configuration with steam side control (above photo, below schematic representation)

Baelz has been supplying clean steam generators for decades. They are designed with our own tried and tested components, ranging from control valves to the heat exchanger, the heart of every system. That is what makes Baelz clean steam generators unique!

Independent boiler plants or district heating distributors deliver superheated steam which does not meet the demands of hygienic standards regarding the sterilization of medical equipment or the air humidity control of air conditioning systems for example.

Primary steam is used as a heating medium to produce clean steam. Appropriately treated feed water is led to the steam generator and heated until clean steam is available at the required pressure and the necessary degree of purity, in order to be reused. High-quality materials on the clean steam side, including the sealing materials, assure a high degree of purity. Systems for other primary fluids such as hot water or hot oil are also available.

The process measuring and control technology monitors feed water quality, controls steam pressure and ensures continuous mud blowdown in the installation. Depending on surroundings, available space and connecting conditions, Baelz supplies customers with the optimum solution in the form of a fully mounted Steam Terminal® with all the necessary components, with a horizontal or upright steam generator – everything from a single source.

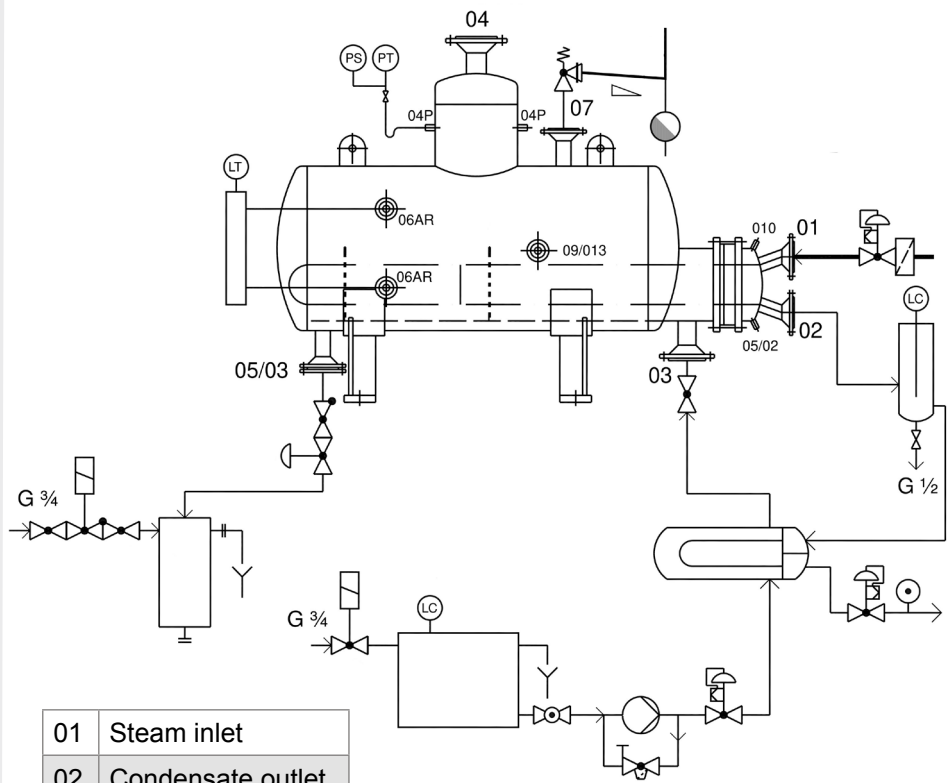

01	Steam inlet
02	Condensate outlet
03	Clean water inlet
04	Clean steam outlet

[Inquiry form](#)



Condensate Terminal®

COLLECTING AND USING CONDENSATE

Depending on the process, condensate is relatively pure and thus represents an excellent source of feed water. Another major advantage of using condensate is the heat content of the condensate. Much less energy is required to convert water supplied at, say, 90 °C back into process steam than for feed water with a water pipe temperature of 20 °C.

ADVANTAGES AT A GLANCE

- Energy saving through use of condensate
- Available in standard capacities from 100 to 2000 liters
- With automatic overflow and dry-running protection
- With temperature and level indicator (depending on model)
- Depending on system requirements, components are pre-assembled on the condensate tank or on a skid for easy assembly and transport

Condensate Terminal® with baelz 128 condensate tank
Photo shows example with optional accessories.

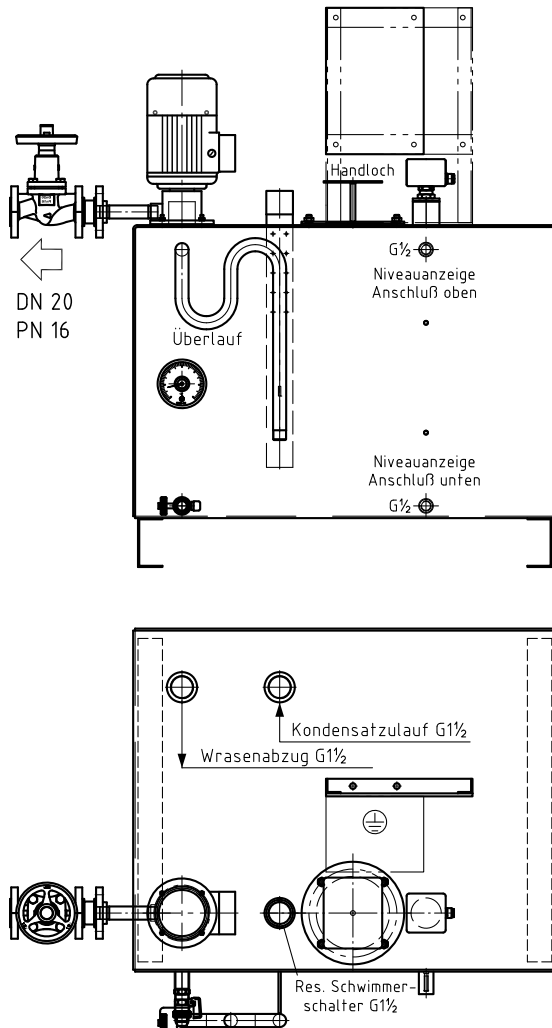

Options / Extra charges

Float switch baelz 783
Level indicator baelz 70730, 70749
Drain valve baelz 70586
Thermometer baelz 71150 or 71141
Check valve baelz 70082
Isolating valve baelz 70027R
Additional pump baelz 740...
Additional condensate inlets
Temperature sensor (special design)
Inlet with solenoid valve (special design)

For systems without a baelz 740 submersible pump, the maximum allowable temperature in the tank is 100 °C instead of 90 °C. (Always observe the nameplate!)

Example of a condensate terminal with baelz 128 condensate tank



Condensate Terminal® with steam pressurized condensate vessel baelz 130 in horizontal configuration

STEAM PRESSURIZED COLLECTING STATIONS - CONDENSATE TERMINAL® WITH BAE LZ 130

- With steam pressurized condensate vessel baelz 130 in upright or horizontal configuration
- Exclusion of air by steam pressure
- Low-oxygen condensate recovery for improved corrosion protection
- Level-dependent controlled condensate return
- Condensate temperature monitoring
- With pressure increase to overcome condensate back pressure
- Backflow prevention by means of an overflow valve in the event of large fluctuations in condensate back pressure (a check valve is sufficient if the condensate back pressure remains constant)
- Safety valve for overpressure protection
- Automatic venting valve for start-up operation

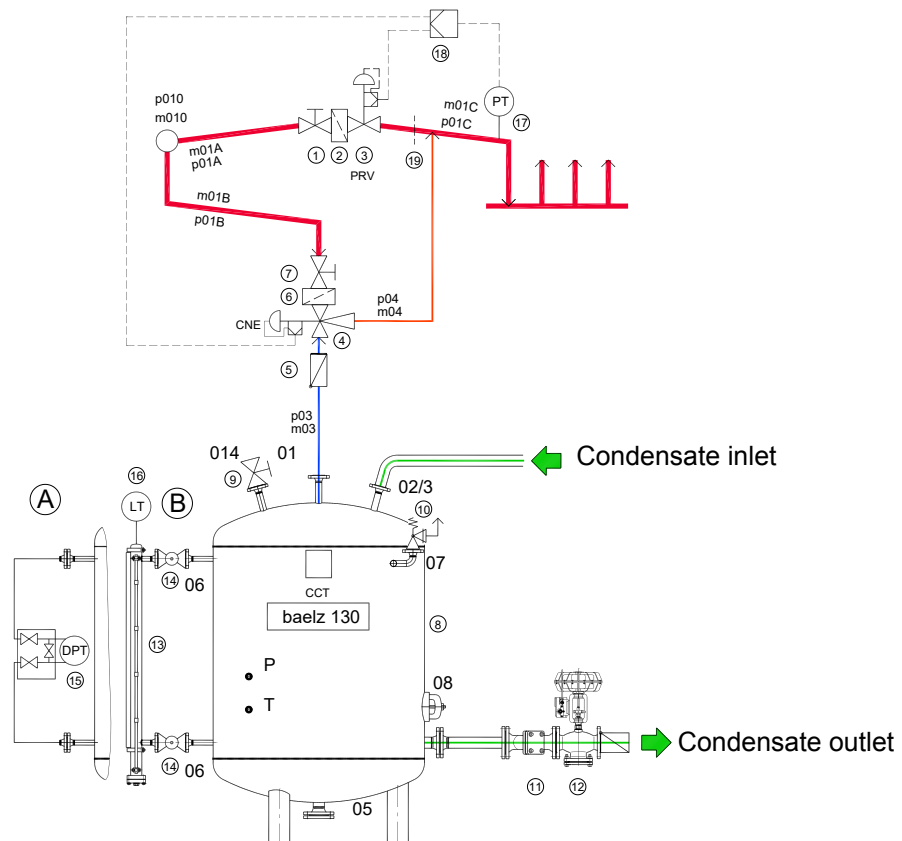

Steam/condensate compact station with steam pressurized condensate vessel baelz 130 in upright configuration and top-mounted controlled steam ejector baelz 590 for exhaust vapor compression

Connection to a condensate system

Condensate with different temperatures and pressures must be brought together in a steam plant. Baelz creates customized solutions tailored to the design of the plant at hand.

EXAMPLES

Two basic ways of mixing hot and cold condensate without water hammer are shown below.

Both systems operate with steam and condensate backup with a steam/water heat exchanger controlled on the condensate side.

EXAMPLE 1

Connection to an existing condensate system by means of an injection cooler baelz 118

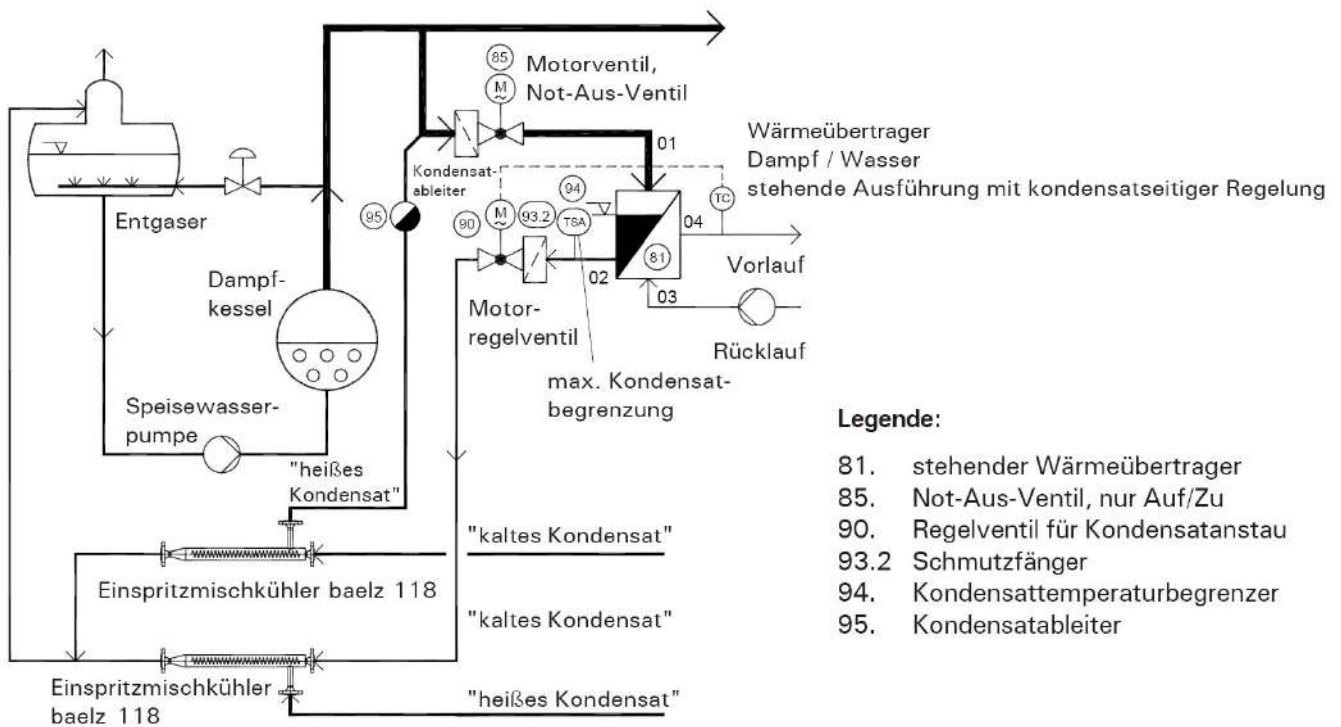

EXAMPLE 2

Connection to an existing condensate system by means of a special condensate terminal

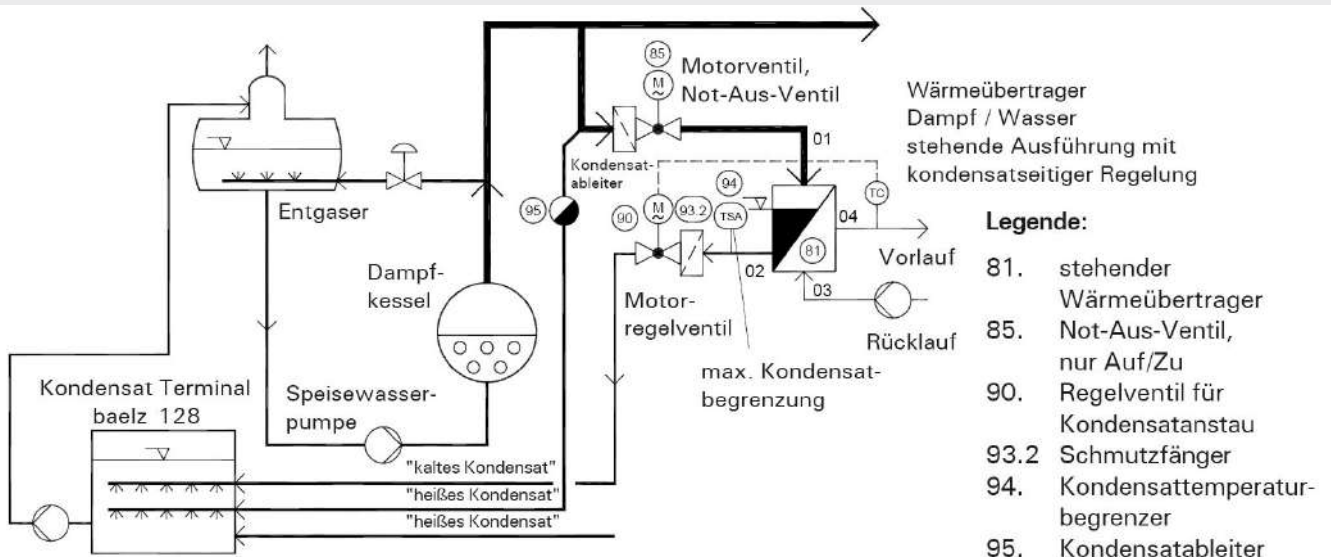

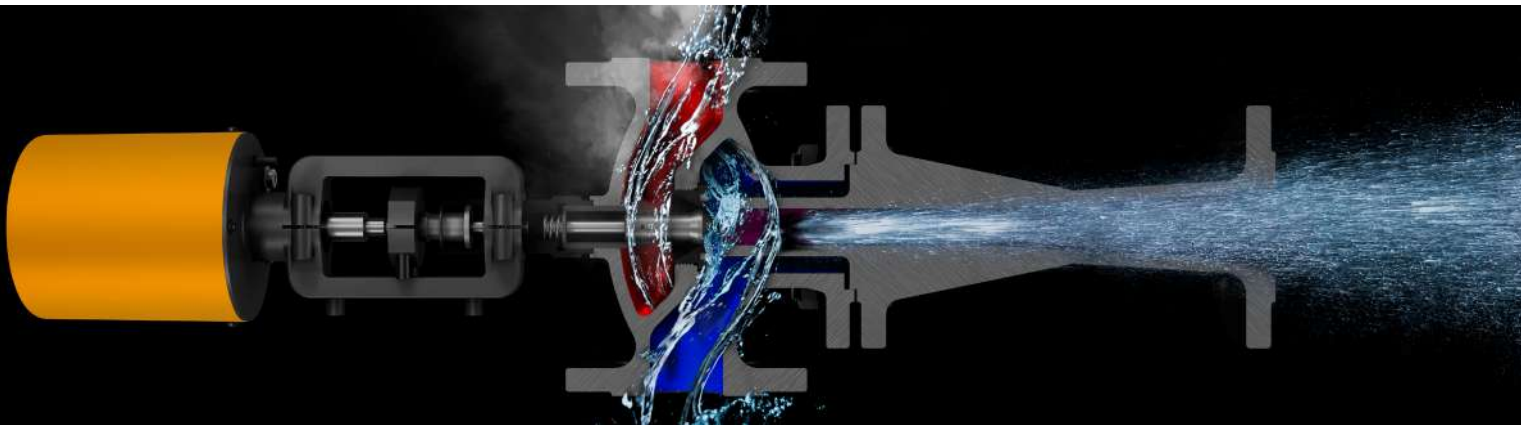

Physical principles of ejectors

Based on the Bernoulli equation, we can deduce that if a fluid flows faster, the pressure in that fluid decreases and vice versa. This phenomenon is called the "Bernoulli Effect", of which perhaps the best known application is the function of an airplane wing: the air which is directed over the upper, more rounded surface has a longer distance to travel and therefore flows faster, creating a lower pressure over the upper surface of the wing than over the lower surface. The difference in pressure between the upper and lower surfaces of the wing creates lift and the aircraft takes off.

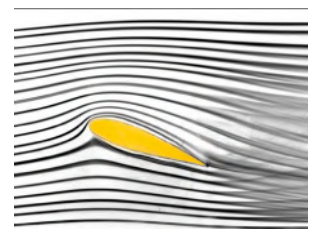

Daniel Bernoulli's (1700-1782) work was continued by Giovanni Battista Venturi (1746-1822). Venturi showed that a fluid flowing through a tube accelerates when the tube becomes narrower and vice versa - now known as the "Venturi effect".

Flow pattern around an aerofoil

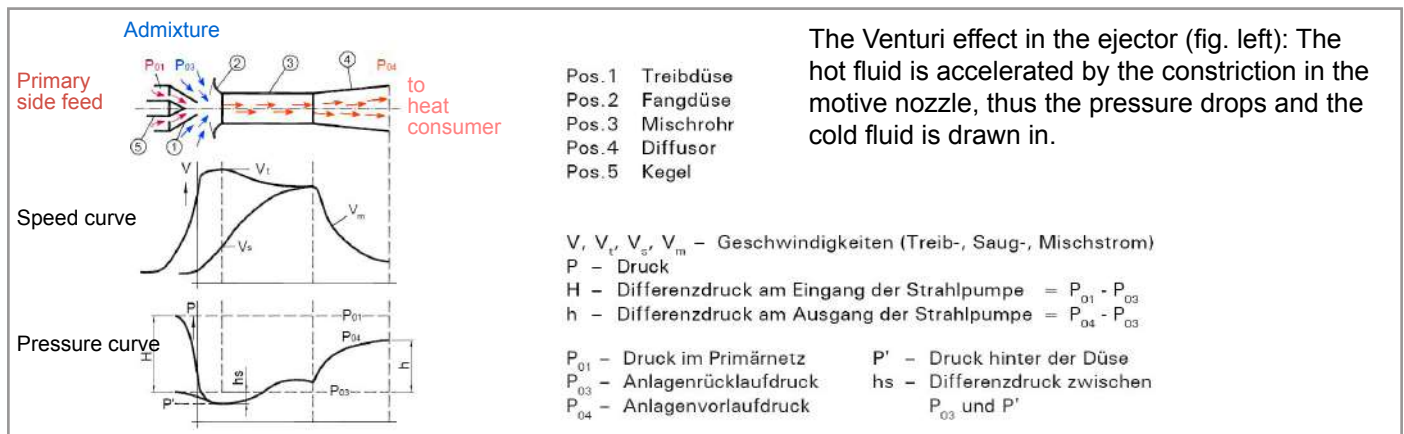

Venturi nozzle

Functional principle of ejectors

The acceleration of the hot fluid in the Venturi nozzle (fig. left) creates a pressure drop at the nozzle outlet, resulting in a suction effect at the 3rd way of the ejector

The hot fluid 01 and the cold fluid 03 are brought together and mix in the cylindrical part of the diffusor.

The speed of the mixture is reduced in the conical part of the diffusor. This increases the pressure according to the pressure drop of the control loop in question (04).

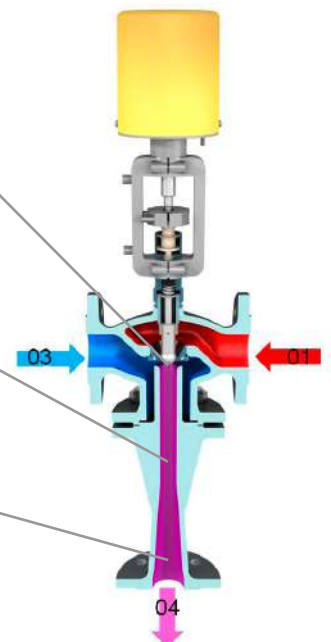

Steam ejector baelz 590



Steam ejector systems can be delivered pre-assembled on a skid (picture above) or as a Baelz system which is installed at the customer's site.

METHOD 1: RECIRCULATION

This technology is used to improve the performance and thus the productivity of machines. Performance increases of 15 % on average are possible, combined with steam savings of up to 5 %. In this type of system, the controlled steam ejector is used for external recirculation with only motive steam as an energy source.

METHOD 2: COMPRESSION

This technology is used purely to save energy. Direct steam savings of 10 to over 30% can be achieved. In this type of system, the controlled steam ejector is used for compression with two energy sources: motive steam and suction steam

ADVANTAGES AT A GLANCE

- Reduction of steam loss
- Increase in machine performance
- Increase in the effective heating surface to 100%
- Applicable to all types of steam systems
- Systems enable full use of available energy
- Applicable for use with various gases

METHOD 1

Recirculation: comparison of conventional solution and ejector solution

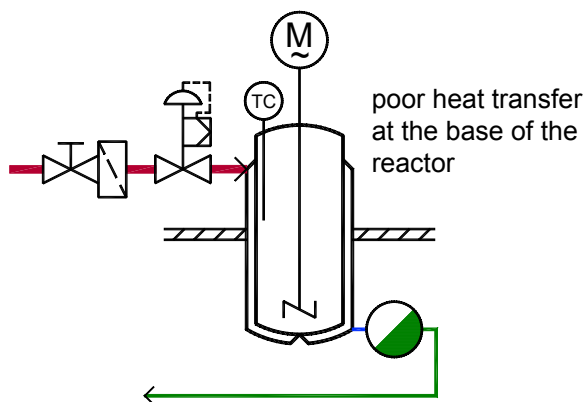

Conventional control
on a double jacketed reactor with steam side valve

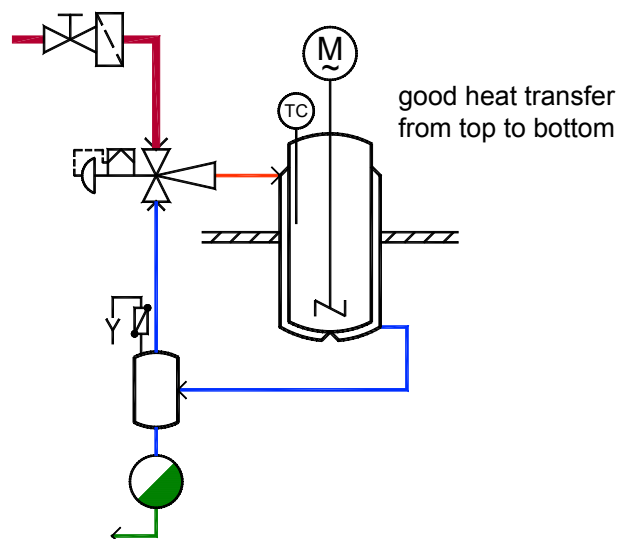

Solution with circulation ejector to ensure good heat transfer from top to bottom

[Inquiry form](#)

METHOD 1

Recirculation: Example and comparison of conventional solution and ejector solution with drum dryers

Conventional solution with control valves, 7 steam traps and lower surface temperature

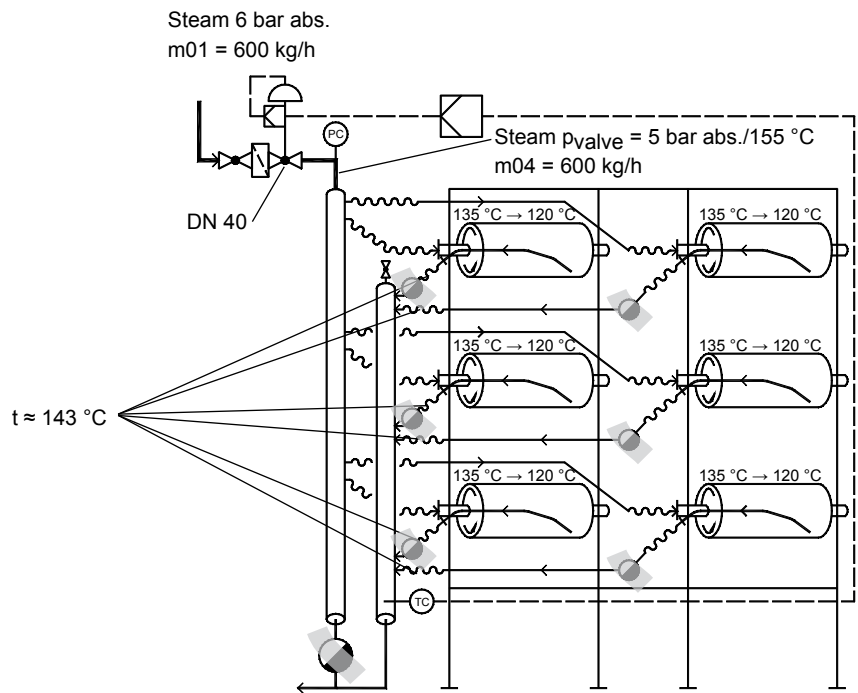

Solution with ejectors, only 2 steam traps and higher surface temperature

- Increased performance
- More efficient use of steam
- Easier drainage of condensate

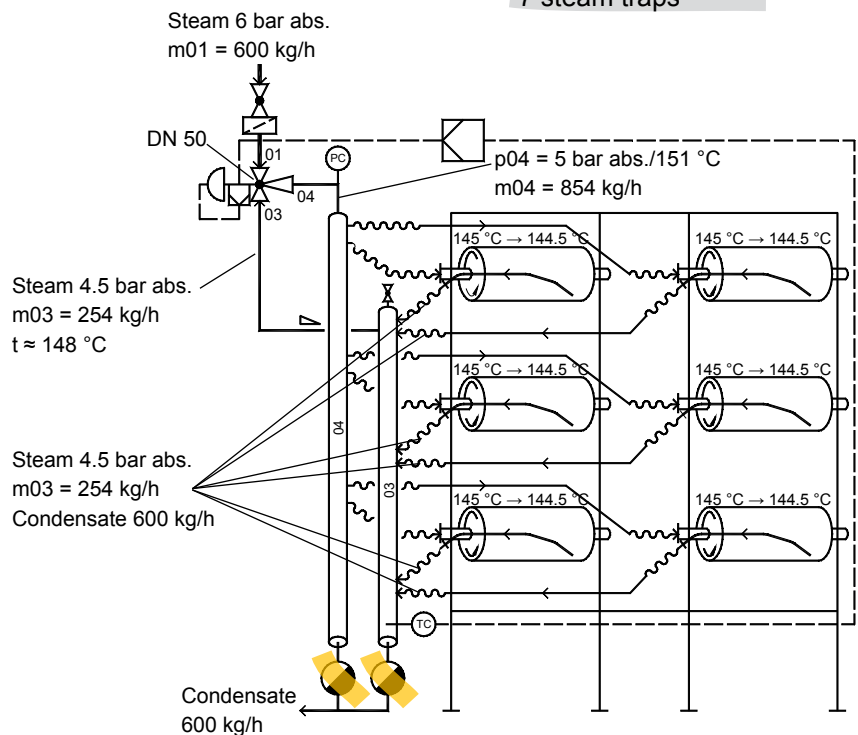

	Conventional	With ejector
Steam pressure at the drum inlets	5 bar abs.	5 bar abs.
Δt above the drum surface	135 °C - 120 °C = 15 °C	145 °C - 144 °C = 1 °C
Number of steam traps	7	2
Steam quantity to be condensed	600 kg/h	600 kg/h
Steam quantity to be returned	-	254 kg/h

METHOD 2

Compression: Flash tank with 2 top-mounted compressors for variable loads and a bypass pressure reducing valve for start-up operation.

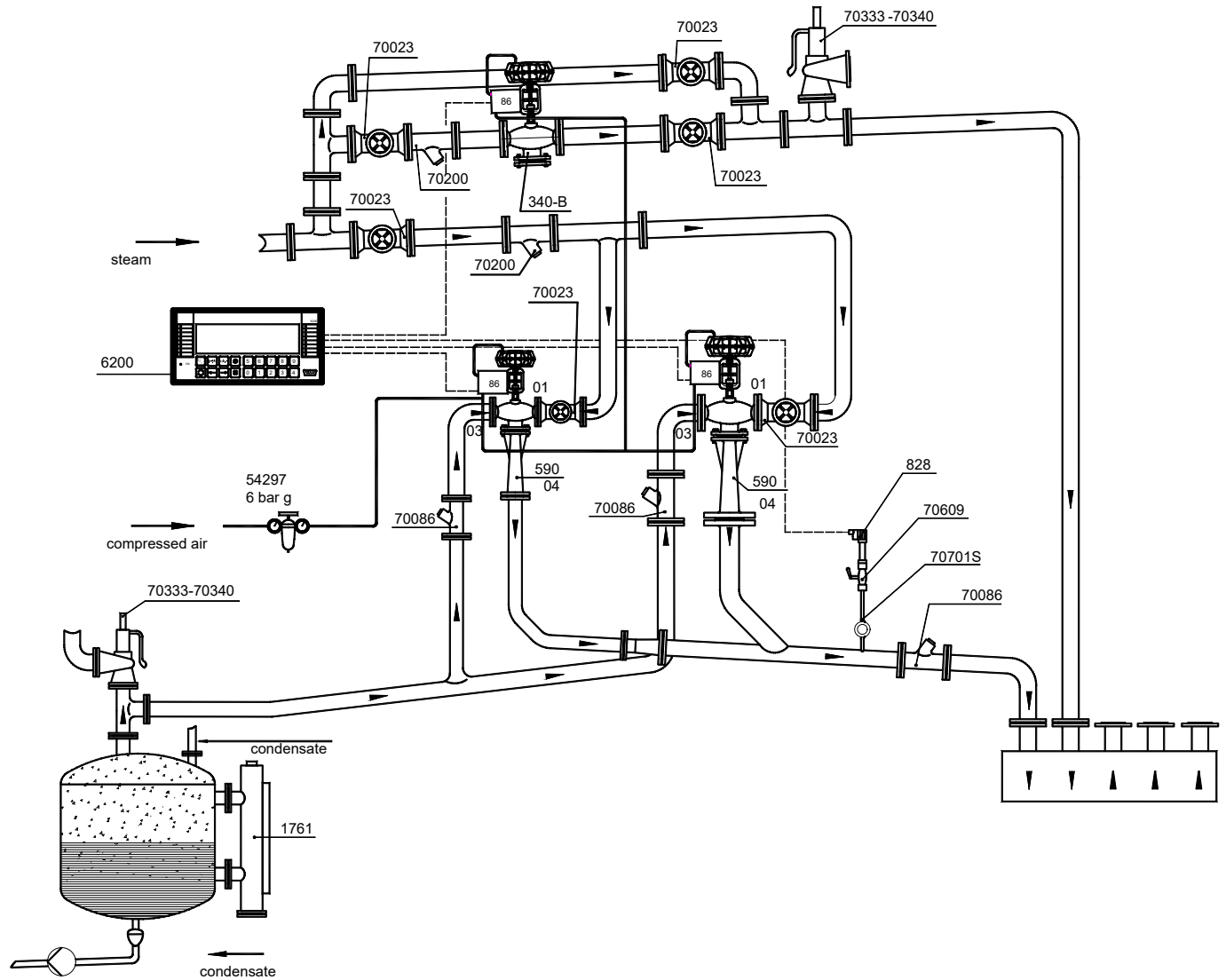

System properties in comparison

System values	Conventional system without steam ejector	System with 2 steam ejectors	Savings per hour with steam ejectors
Waste steam	-	26 kg/h	
Primary steam	2000 kg/h	1974 kg/h	
Steam pressure	6 bar	6 bar	
Steam temperature	165 °C	165 °C	
Feed water temperature	100 °C	158.9 °C	
Steam loss to atmosphere from open condensate tank	240 kg/h	20 kg/h	
Steam boiler efficiency	85 %	85 %	
Energy at steam boiler inlet	1558 kW	1350 kW	208 kW
Fuel consumption - oil / gas	132 kg/h / 177 Nm³/h	114 kg/h / 153 Nm³/h	18 kg/h / 24 Nm³/h
Additional consumption of treated water	240 kg/h	20 kg/h	220 kg/h

Die Baelz-Dampfstrahlpumpe baelz 590 finden Sie im Kapitel "Strahlpumpen" ab Seite <?> dieses Katalogs.

Superheated steam cooling & pressure reduction baelz 591



Steam ejector systems can be delivered pre-assembled on a skid (picture above) or as a Baelz system which is installed at the customer's site.

METHOD 3: SUPERHEATED STEAM COOLING / SATURATED STEAM GENERATION

Due to the very fine atomization of water injected into the primary steam, the exchange surface area for evaporation is increased dramatically. This opens up new possibilities in the production process.

The water is injected through a special nozzle (see figure below). The water droplets are further nebulized by the fast flowing steam. This ejector with internal recirculation - used either as pressure reducing desuperheater or as a generator of saturated or wet steam - has several advantages compared to conventional desuperheaters.

ADVANTAGES AT A GLANCE

- Saturated steam generation without any superheating thanks to internal recirculation
- Higher accuracy in pressure and temperature control
- Excellent atomization of the injected water
- Greater product diversity of the production plant possible
- Improved product quality
- You benefit from Baelz expertise in the design process

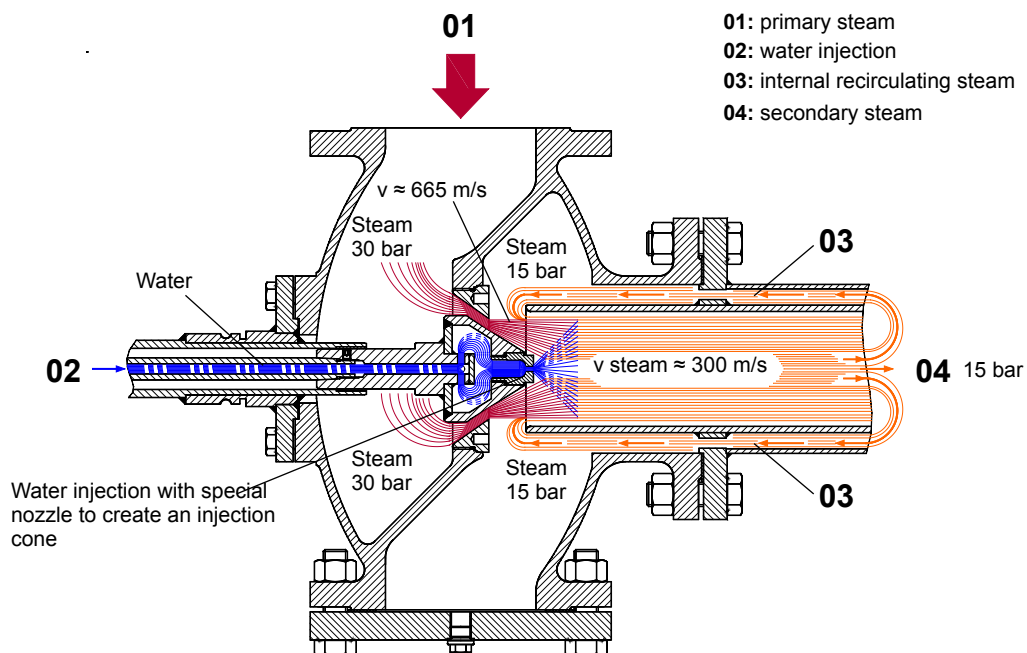

Function of steam cooling and reducing Jetomat® baelz 591 with operating speeds

baelz 591 installations - comparative values					
Parameters	Installation in the food industry		Installation in the chemical industry		Results at a glance
	Existing situation	baelz 591 system	Existing situation	baelz 591 system	
Input parameter	6 bar abs. / 160 °C	6 bar abs. / 160 °C	20 bar abs. / 250 °C	20 bar abs. / 250 °C	<ul style="list-style-type: none"> • Better control performance • Greater product diversity possible • Improved product quality
Output to consumer	2.0 bar abs. / 160 °C SUPERHEATED!	2.0 bar abs. / 121 °C (saturated steam)	3.5 bar abs. / >200 °C SUPERHEATED!	3.5 bar abs. / 140 °C (saturated steam)	
Steam quantity	300 kg/h	300 kg/h 294 kg/h primary steam	5000 kg/h	5000 kg/h 4674 kg/h primary steam	
Cooling water temp.	-	20 °C	-	60 °C	

METHOD 3

Superheated steam cooling / saturated steam generation: More flexibility and improved product quality, for example in the textile industry.

Conventional solution

Textile steamer with evaporation in bottom water bath

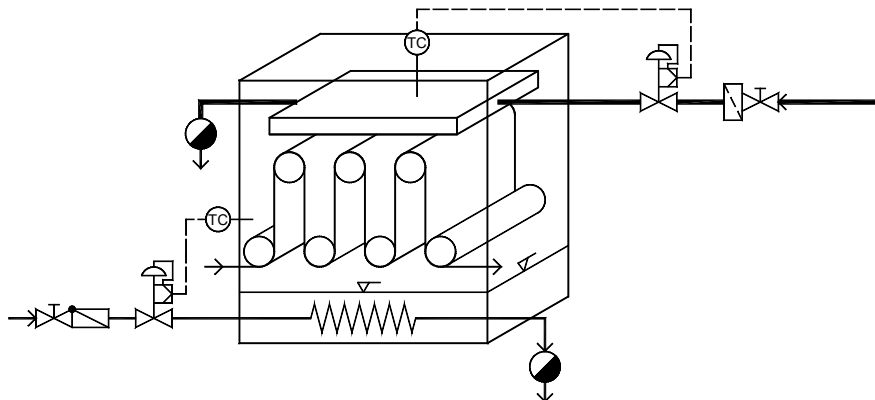

Solution with saturated steam generation

Textile steamer with steam ejector baelz 591 for generating saturated steam at approx. 103 °C

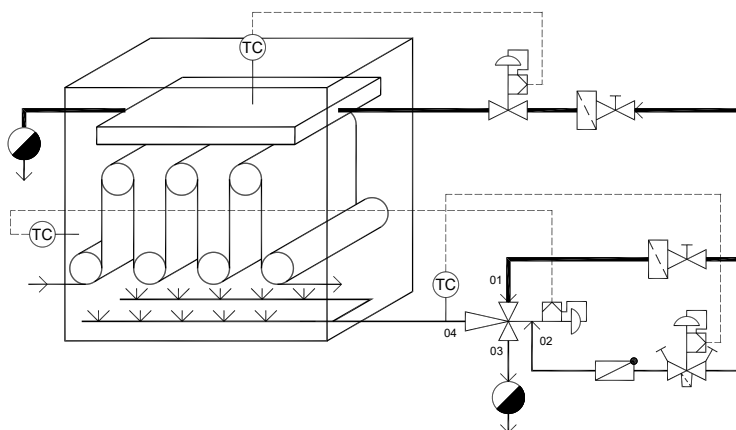

Pressure reducer desuperheater with condensate tank for water injection

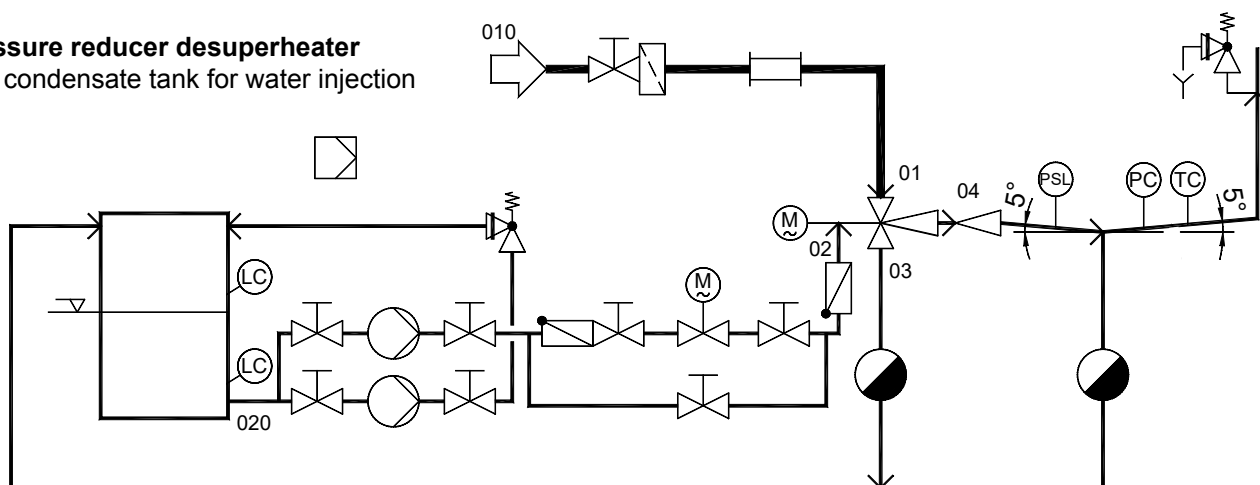

Die Baelz-Dampfstrahlpumpe baelz 591 finden Sie im Kapitel "Strahlpumpen" ab Seite <?> dieses Katalogs.



Steam ejector systems can be delivered pre-assembled on a skid (picture above) or as a Baelz system which is installed at the customer's site.

Mixing ejectors baelz 585

WATER HEATING WITH DIRECT STEAM INJECTION

In the steam/water mixing ejector baelz 585 water is mixed with steam to reliably supply warm water at the desired temperature. It comes with an actuator, temperature sensor and control unit to enable fully integrated process control.

ADVANTAGES AT A GLANCE

- Optimal use of the motive power of steam during the transfer of the water to be heated
- Optimal mixing through steam condensation in water
- Silent operation due to the specially designed mixing chamber
- Fully integrated process control possible
- Low investment costs
- Can also be used with other liquids

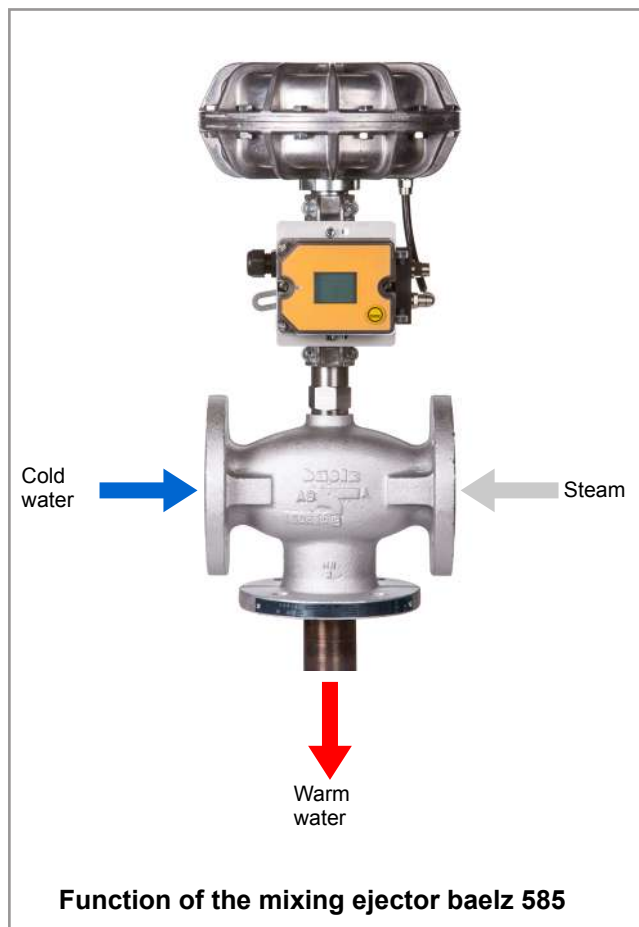

Application example:
Water heating with direct steam injection

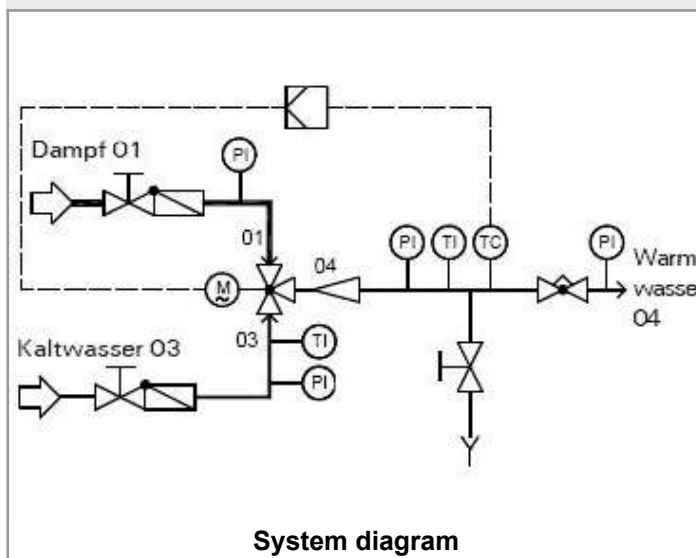

Die Baelz-Dampfstrahlpumpe baelz 585 finden Sie im Kapitel "Strahlpumpen" ab Seite <?> dieses Katalogs.

Water ejector systems Moduline

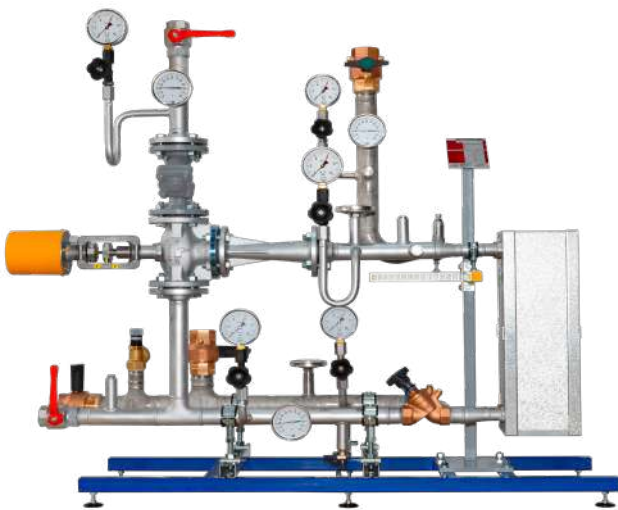

Moduline compact warm water station with plate heat exchanger baelz 140 and water ejector Jetomat® baelz 480
Water ejector systems can be delivered pre-assembled on a skid (picture above) or as a Baelz system which is installed at the customer's site.

ONLY ONE PUMP PER SYSTEM, ENERGY SAVING

The controlled water ejector based on the Baelz-hydrodynamic® process combines the functions of four individual components: It generates circulation in the area of the consumer, it adjusts circulation volume according to the actual heat requirement, it regulates temperature and compensates for fluctuations in differential pressure.

Where secondary heating water is usually distributed in the heating circuits using control valves with one electric pump each, Baelz uses controlled ejectors with only one main pump.

Many heating and ventilation systems have been in operation for over 30 years, saving electricity and money.

ADVANTAGES AT A GLANCE

- Good controllability over the entire load range
- Only one main pump, meaning lower energy costs
- Simplified system design due to fewer components
- Less data points in the superordinate control system
- Lower return temperatures
- Hydraulic stability

Admixture control with ejectors

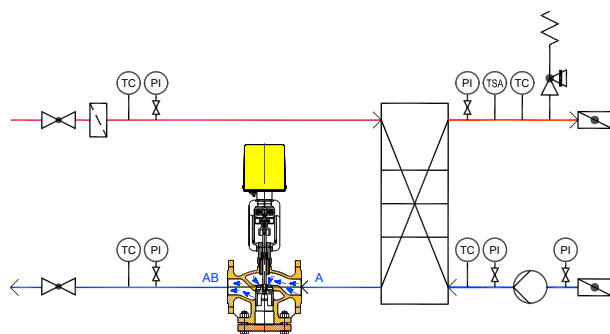

Throttle circuit

In a **throttle circuit**, the inlet temperature into the heat exchanger is always equal to the primary flow temperature in the supply network. A primary inlet temperature that is too high often leads to calcification during water processing. The heat output is controlled by changing the mass flow rate. Controlling the heat output exclusively by changing the volume causes a greater temperature difference between the inlet and outlet of the mass flow in partial load operation. Large temperature differences create thermal stresses, which are a frequent cause of damage to heat exchangers. In addition, a low water flow rate in partial load operation causes poor heat transfer in the heat exchanger.

Compared to the throttle circuit described above, an **admixture circuit** with control valve and circulating pump offers many advantages. For financial reasons, however, this option is often not chosen. By using an ejector instead of the control valve with circulation pump, admixture control can be achieved without additional costs. The ejector can be mounted directly on the heat exchanger.

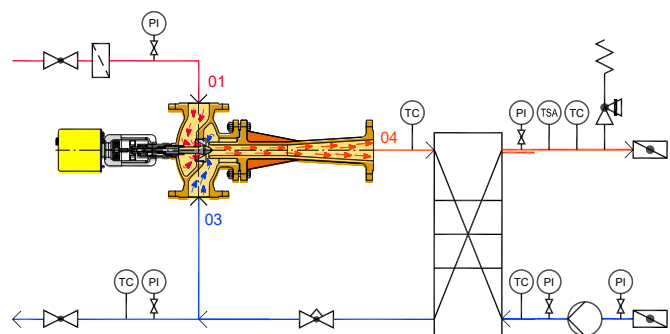

Admixture circuit with an ejector

For information on Baelz water ejectors, see the "Ejectors" chapter beginning on page 76 of this catalogue.

Water ejectors - economical, flexible and versatile:



Station with distributor assembly and baelz 480 water ejectors.



Tankless water heater system



Tankless water heater with distributor and 3 heating circuits

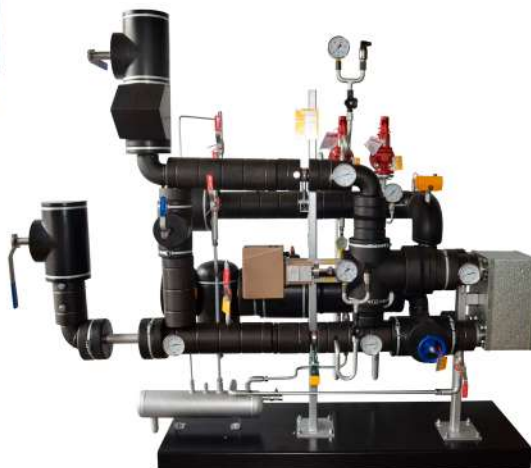

Heating station – Baelz supplies fully insulated stations on request.

Ejector technology saves electricity as electric pumps are usually rendered unnecessary. Where pumps are needed to return water into the circuit in conventional plants - the flow energy having been dissipated in control valves or differential pressure regulators - controlled Baelz ejectors enable the flow energy in district heating and hot water systems to be retained at all times. Ejectors therefore result not only in lower energy and investment costs but also in fewer components and fewer moving parts. The customer is provided with a durable, low-maintenance and reliable system with significantly lower maintenance and repair costs.

In addition to the baelz 480 water ejectors, suitable for use with water, liquids and thermal oil, we also offer smaller ejectors for direct use at the heating surface.

Baelz ejector technology can be delivered as part of a ready-to-use station (example, see picture above) or can be installed at the customer's site (example, see picture on next page).



Heat transfer station with ejector heating distributor and buffer tank; Baelz head office, Heilbronn

Small selection of Baelz reference projects with water ejector technology

Product	Company	Country	Industrial sector
50 x baelz 480 with P21	Bundesinstitut für Risikobewertung, Berlin	Germany	Building technology
3x baelz 471 with E07	Vattenfall	Germany	Building technology
1 x 480 with E07	Ukrspn	Ukraine	Power plant
1 x 480 with E07	Cathedral	Belgium	Building technology
baelz 480	Ford Werke	Germany	Automotive
baelz 471, baelz 475	Ante-Holz	Germany	Timber industry

Example of a Baelz system at a pharmaceutical company:

A leading Southern German pharmaceutical company was planning a new modular production building at its site. The building was to be supplied with cold water, cooling water, steam, drinking water and compressed air by a central power plant. Until then, all building systems on the site were planned conventionally. In the case of the modular production building, however, the decision was taken to utilize ejector technology for the first time.

The use of ejector technology reduced the number of fittings and hence also the number of data points significantly. In this case, about 1800 euros were saved on data points per group. The following illustration shows the optimized hydraulics of the system.

Optimized distribution system with Baelz ejector technology

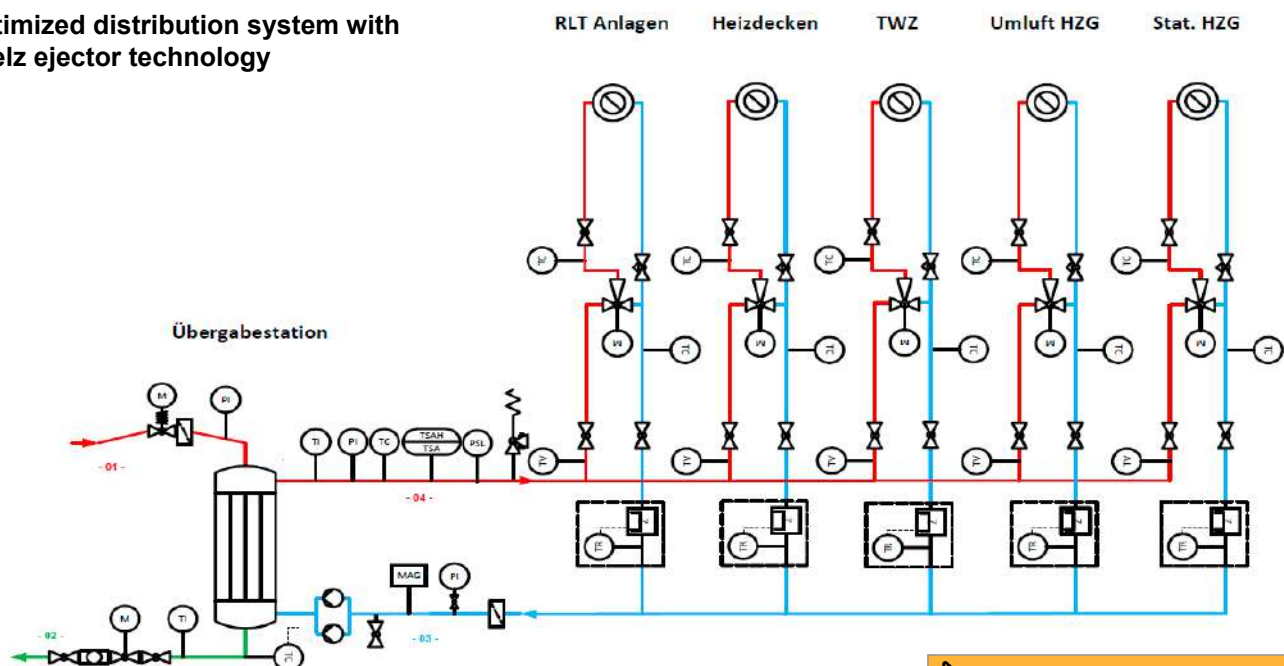

Baelz absorption chillers

BEE, BUMBLEBEE, HORNET

Baelz-absorpdynamic® absorption chillers are suitable for cooling industrial plants, rooms, machines and food, but can also be used in winter for generating heat. Possible heat sources are waste heat from combined heat and power plants or from industrial or combustion plants as well as district heating.

ADVANTAGES AT A GLANCE

- High spreads for district heating applications > 40 K
- Thermal process efficiency, COP up to 0.80
- Low heat source temperatures from 60 °C possible
- Process design for dry recooling
- Use as heat pump for heating systems up to 45 °C
- Fast response, 25 % to 100 % power < 10 minutes
- Good access through doorways, <0.97m x 1.60m x 2.05m (Bee)
- Efficient system control for min. operation/energy costs

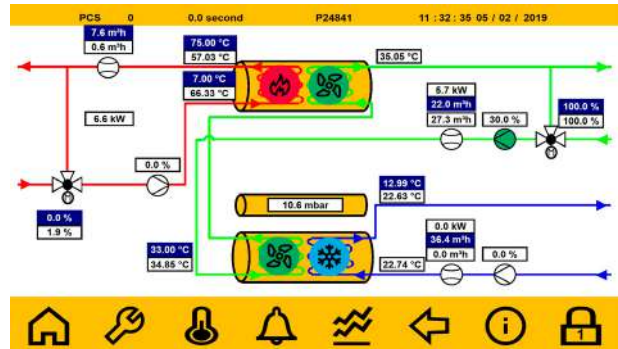

OPERATING SOFTWARE TOUCHPILOT®

The operating software was specially developed by Baelz for controlling the Baelz absorption chillers Bee, Bumblebee and Hornet. With its intuitive application and clear user interface for quick navigation (shown above), it combines functionality and user-friendliness.

Functional principle

In contrast to electrically operated vapor-compression chillers, absorption chillers generate cold by using thermal energy. The principle of the absorption process is based on a closed circuit of separation and recombination of two liquids (refrigerant and solvent) to achieve a cooling effect. A lithium bromide solution with water as a refrigerant is ideally suited on account of the excellent thermodynamic, caloric and physical properties, as well as lithium bromide being absolutely safe for those working with it in this context. The global warming potential value (GWP) being 0, the system does not fall under the F-Gas regulation.

The illustration below shows the functional diagram of an absorption chiller.

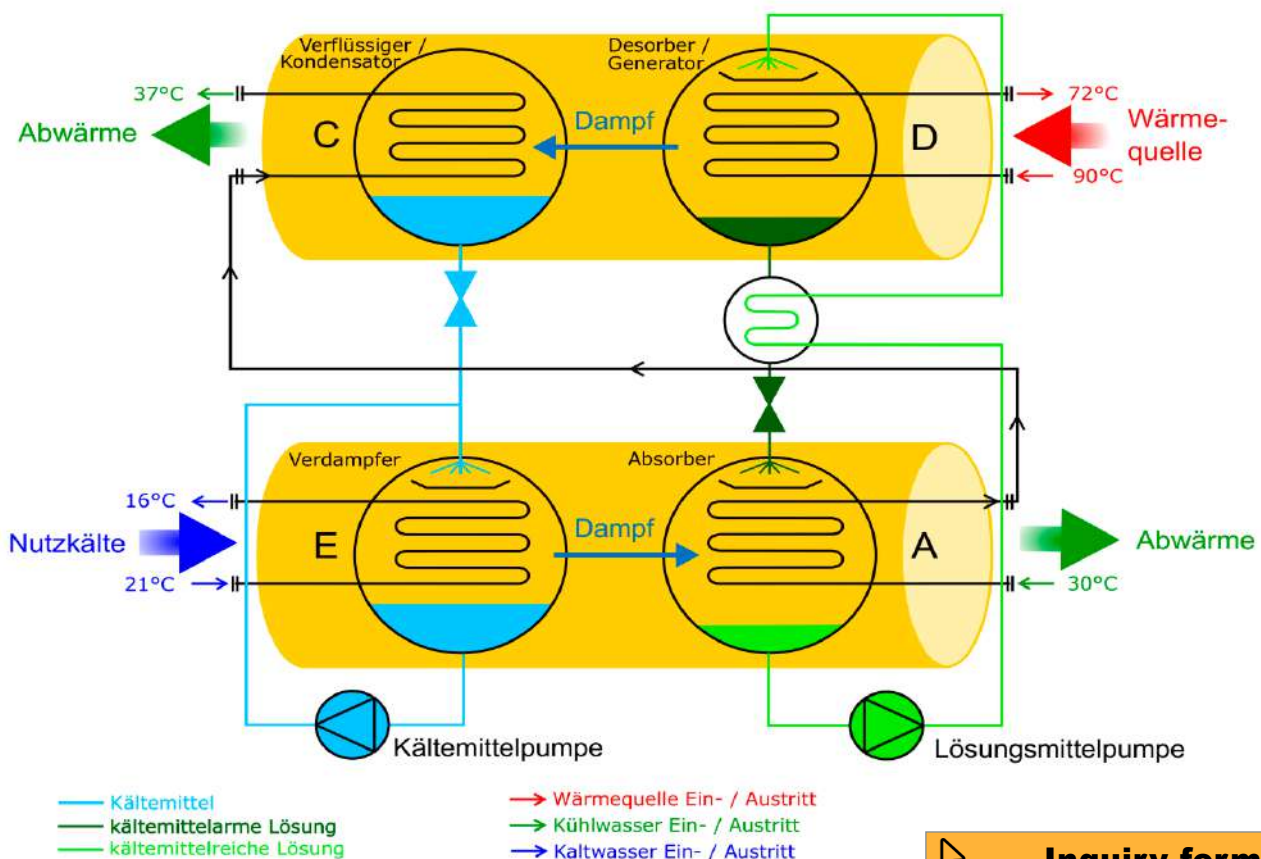

Source: TU (Technical University) Berlin

[Inquiry form](#)



Absorption chiller Bee

BEE

The Bee is the smallest Baelz absorption chiller. It is ideally suited for installation in confined spaces and for difficult access conditions. Thanks to its compact design (only 97 cm wide!), access through doorways is also possible.

TECHNICAL SPECIFICATIONS

Type:	Single effect LiBr-H ₂ O
Cooling capacity:	50 kW
Coefficient of performance:	0.80
Tmin (hot water / cold water):	60 °C / 5 °C
Tmax (cooling water):	40 °C
L / H / W:	2.19 / 1.60 / 0.94 m
Structural weight:	1,100 kg
Operating weight:	1,360 kg
Max. weight in case of damage:	1,944 kg
Current type:	400 V / 3 phases / 50 Hz
Power consumption:	max. 400 W (without external field devices)

Characteristic curves (thermal) - General conditions for reference operating point

- a) Cooling water inlet: 26°C / 30°C / 34°C
 Volume flow: nominal operating data
 Cold water inlet: 21 °C

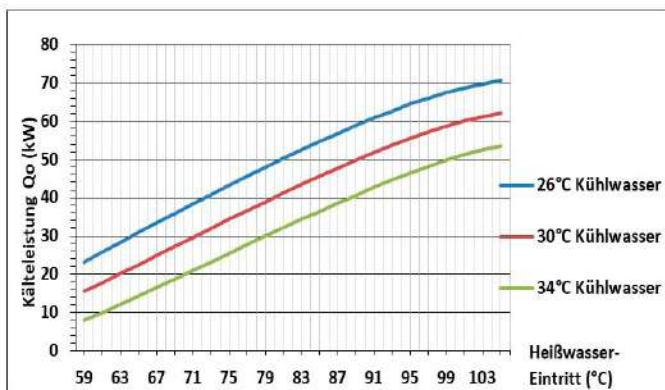

- b) Cold water inlet: 26°C / 30°C / 34°C
 Volume flow: nominal operating data
 Hot water inlet: 90 °C

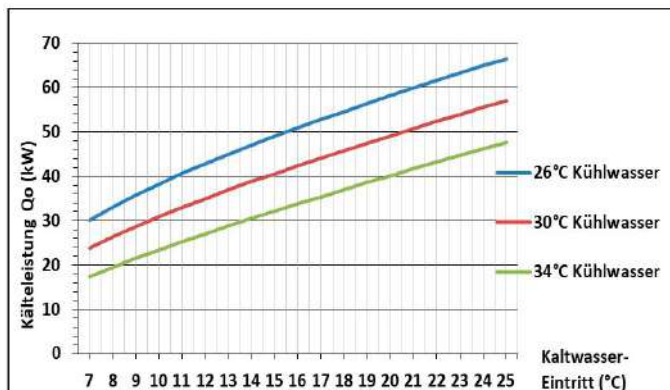

- c) Hot water inlet: 80°C / 85°C / 90°C
 Volume flow: nominal operating data
 Cooling water inlet: 30 °C

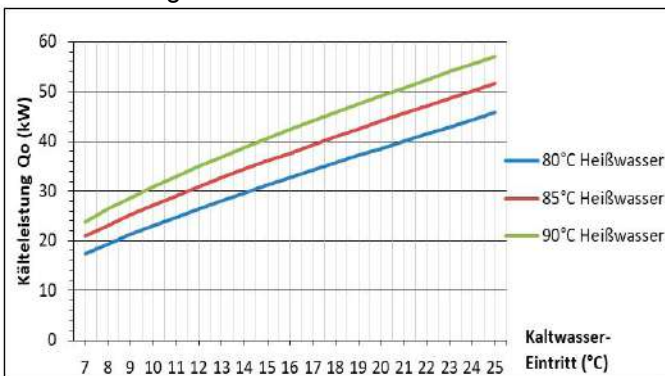

- d) Cooling water/Cold water inlet: 30°C / 21°C
 Volume flow: nominal operating data
 Hot water inlet: 90 °C

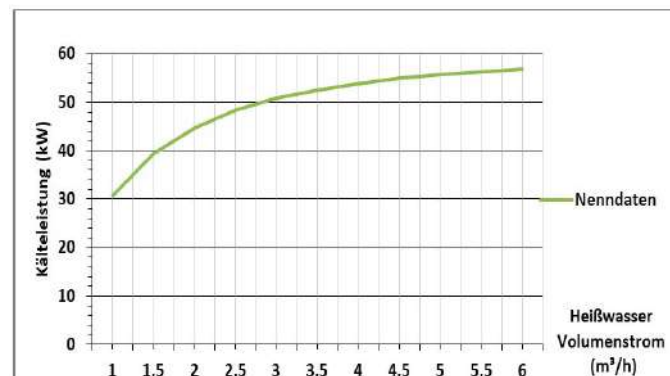

Nominal operating data	Units	Value
Cooling capacity	kW	50
Heating capacity	kW	62,5
Heat consumption	kW	112,5
Coefficient of performance		0,8
Cold water		
Inlet temperature	°C	21
Outlet temperature	°C	16
Volume flow rate	m ³ /h	8,6
Pressure loss	kPa	50
max. pressure	bar	6
Connections V1 / V2	DN / PN	50 / 16
Heat source		
Inlet temperature	°C	90
Outlet temperature	°C	72
Volume flow rate	m ³ /h	3,0
Pressure loss	kPa	6
max. pressure	bar	16
Connections D1 / D2	DN / PN	50 / 16
Cooling water		
Inlet temperature	°C	30
Outlet temperature	°C	37
Volume flow rate	m ³ /h	13,8
Pressure loss	kPa	74
max. pressure	bar	6
Connection A1 in	DN / PN	50 / 16
Connection C2 out	DN / PN	40 / 16

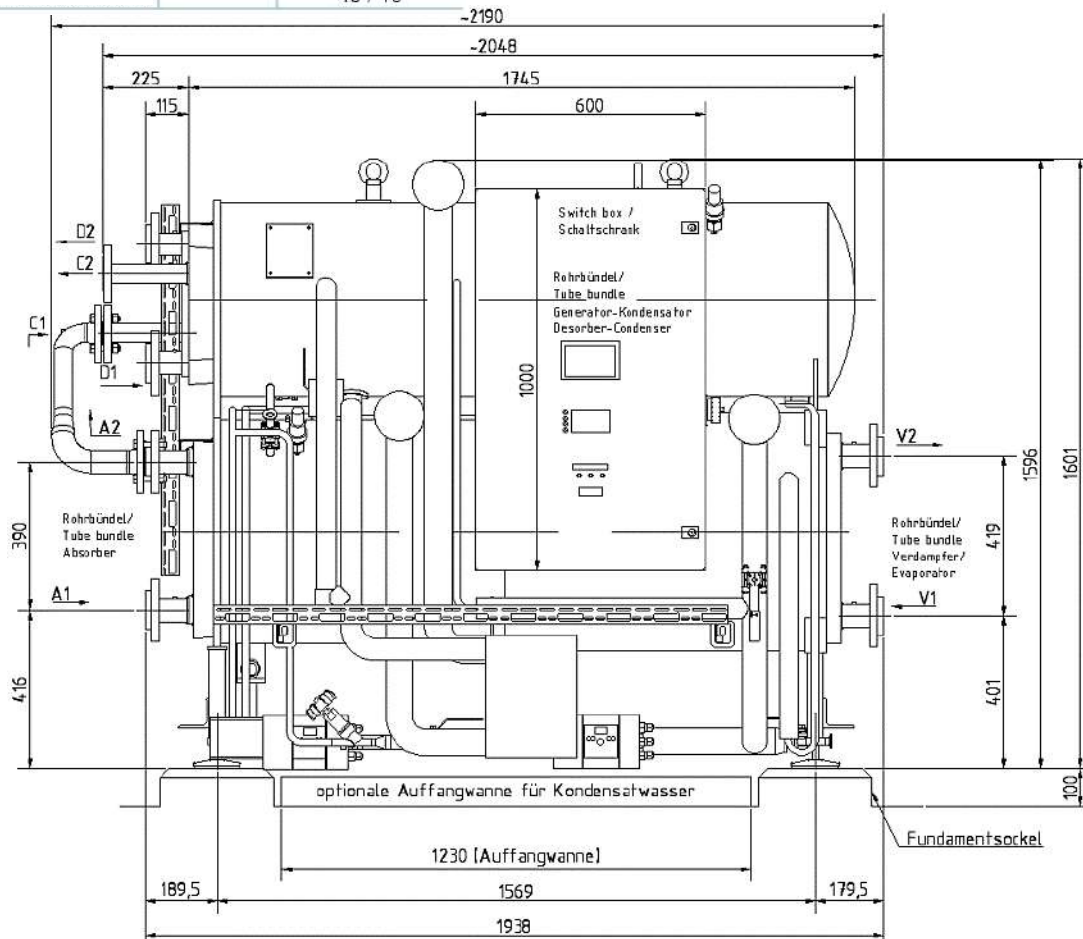
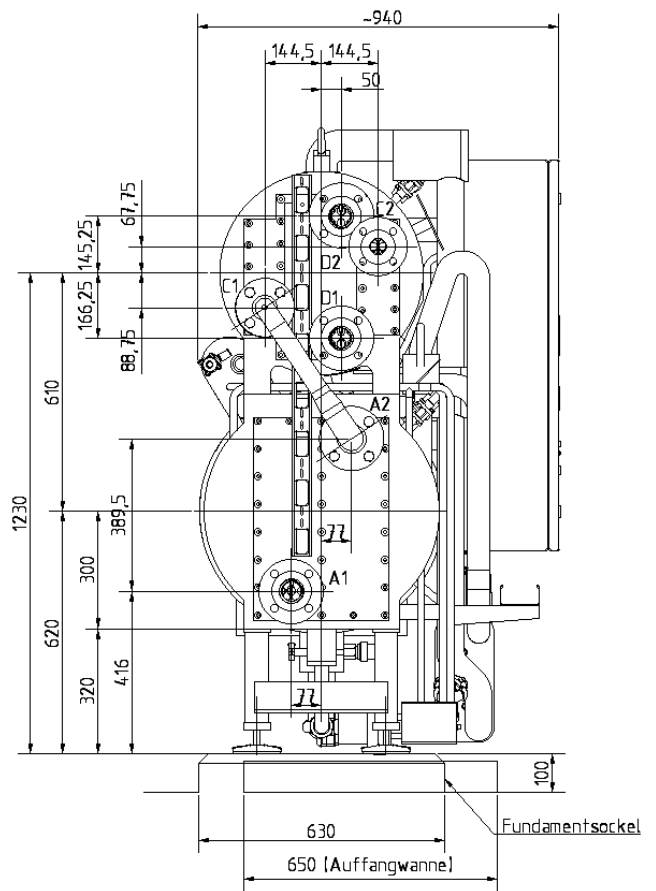

Absorption chiller Bumblebee

BUMBLEBEE

The Bumblebee is Baelz's best-selling absorption chiller. It is powerful yet compact and is particularly suitable for industrial plants with process cooling (combined heat and power plants, waste heat from compressed air systems).

TECHNICAL SPECIFICATIONS

Type:	Single effect LiBr-H ₂ O
Cooling capacity:	160 kW
Coefficient of performance:	0.80
Tmin (hot water / cold water):	60 °C / 5 °C
Tmax (cooling water):	40 °C
L / H / W:	2.41 / 2.14 / 1.13 m
Structural weight:	2,100 kg
Operating weight:	2,730 kg
Max. weight in case of damage:	3,870 kg
Current type:	400 V / 3 phases / 50 Hz
Power consumption:	max. 700 W (without external field devices)



Characteristic curves (thermal) - General conditions for reference operating point

- a) Cooling water inlet: 26°C / 30°C / 34°C
 Volume flow: nominal operating data
 Cold water inlet: 21 °C

- b) Cold water inlet: 26°C / 30°C / 34°C
 Volume flow: nominal operating data
 Hot water inlet: 90 °C

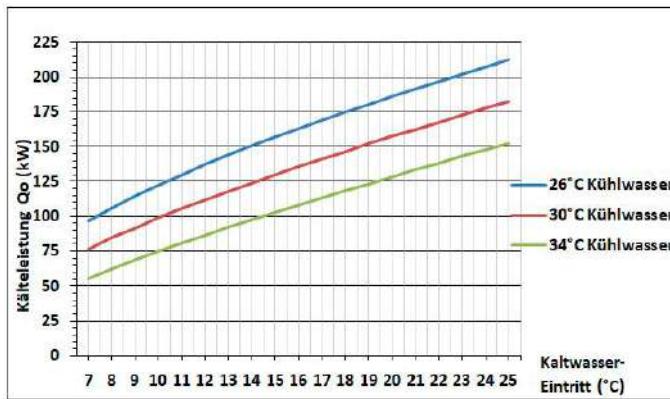
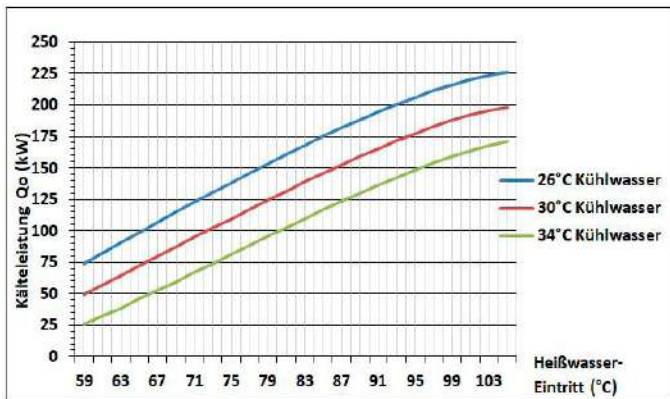

- c) Hot water inlet: 80°C / 85°C / 90°C
 Volume flow: nominal operating data
 Cooling water inlet: 30 °C

- d) Cooling water/Cold water inlet: 30°C / 21°C
 Volume flow: nominal operating data
 Hot water inlet: 90 °C

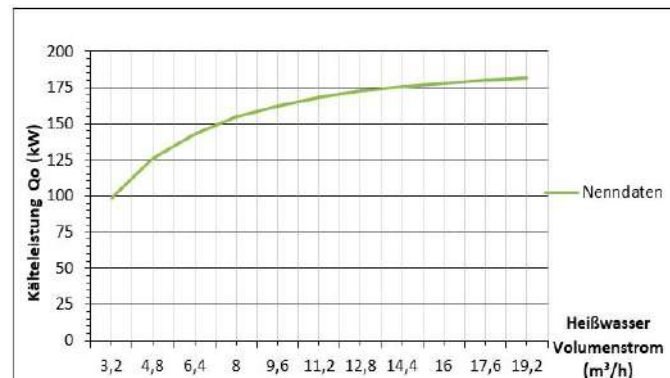
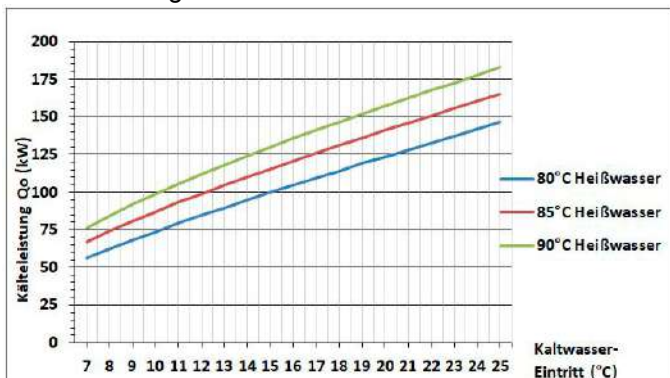



Absorption chiller Hornet

HORNET

The Hornet is the largest Baelz absorption chiller. With a nominal cooling capacity of 500 kW, it is suitable for applications with increased cooling load and for more demanding industrial applications.

TECHNICAL SPECIFICATIONS

Type:	Single effect LiBr-H ₂ O
Cooling capacity:	500 kW
Coefficient of performance:	0.80
Tmin (hot water / cold water):	60 °C / 5 °C
Tmax (cooling water):	40 °C
L / H / W:	3.74 / 3.24 / 1.77 m
Structural weight:	8,200 kg
Operating weight:	10,400 kg
Max. weight in case of damage:	17,300 kg
Current type:	400 V / 3 phases / 50 Hz
Power consumption:	max. 700 W (without external field devices)

Nominal operating data	Units	Value
Cooling capacity	kW	500
Heating capacity	kW	625
Heat consumption	kW	1125
Coefficient of performance		0,8
Cold water		
Inlet temperature	°C	21
Outlet temperature	°C	16
Volume flow rate	m ³ /h	85,9
Pressure loss	kPa	24
max. pressure	bar	6
Conn. V1/1+2 / V2/1+2	DN / PN	4x 80 / 16
Heat source		
Inlet temperature	°C	90
Outlet temperature	°C	72
Volume flow rate	m ³ /h	29,8
Pressure loss	kPa	42
max. pressure	bar	16
Conn. D1/1+2 / D2/1+2	DN / PN	4 x 80 / 16
Cooling water		
Inlet temperature	°C	30
Outlet temperature	°C	37
Volume flow rate	m ³ /h	138
Pressure loss	kPa	79
max. pressure	bar	6
Conn. A1/1+2 / C2	DN / PN	2 x 80+100 / 16

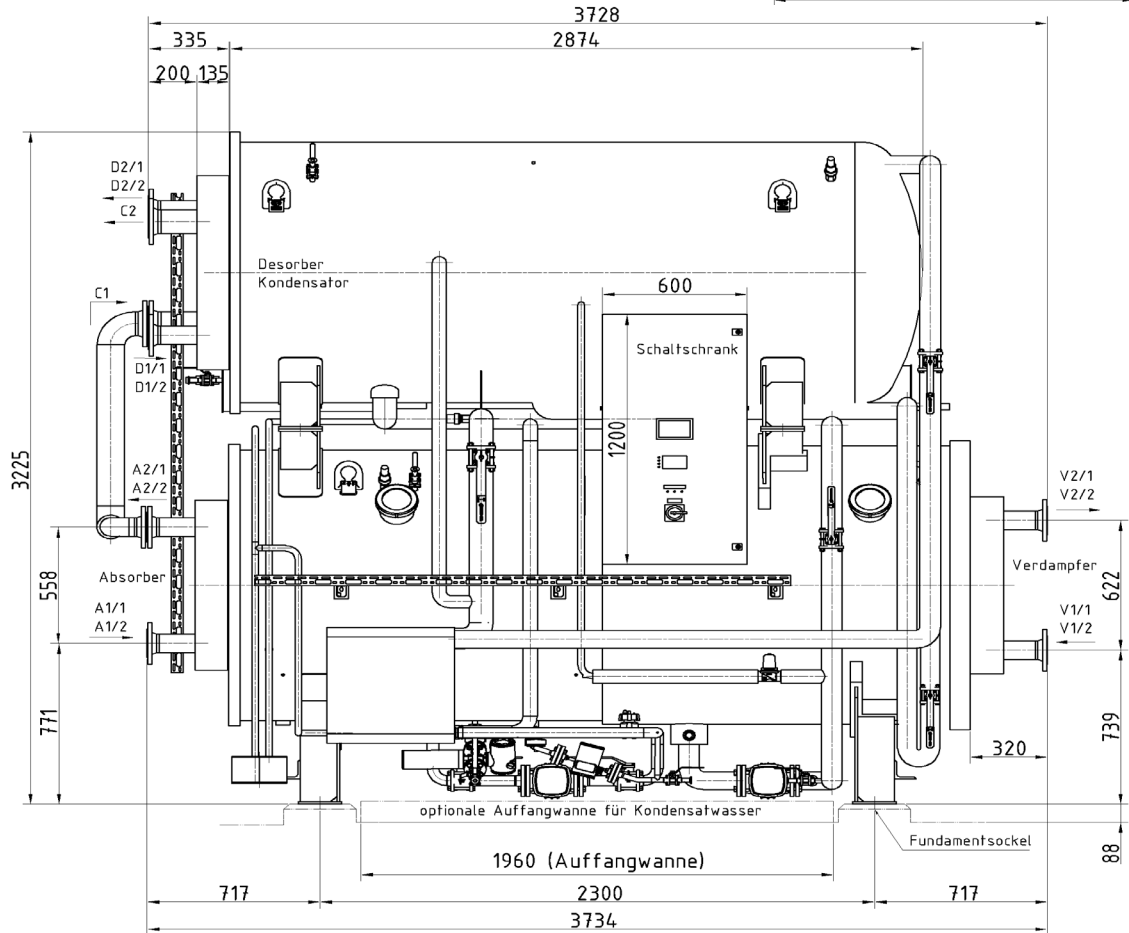
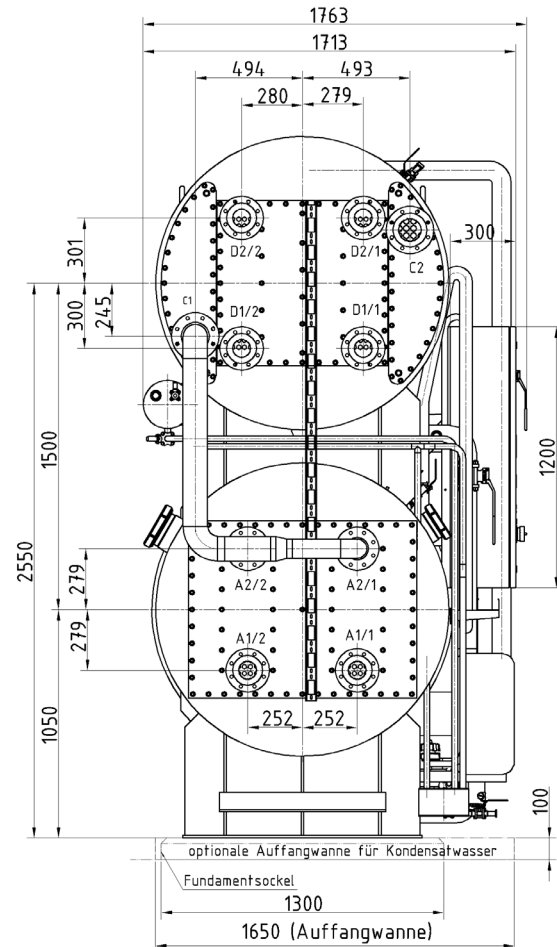

page 214

baelz 22



Room temperature sensor

- For residential rooms, offices, etc.
- Wall mount
- For outdoor installation
- Measuring element PT100 or NTC
- Housing made of polycarbonate, pure white
- Ingress protection rating IP 30
- Ambient temperature: -35 ... +70 °C

page 214

baelz 23



Outdoor temperature sensor

- Wall mount
- For outdoor installation
- Measuring element PT100 or NTC
- Housing made of polycarbonate, pure white
- Ingress protection rating IP 65
- Ambient temperature: -35 ... +90 °C
- Fasteners included

page 215

baelz 24



Immersion temperature sensor

- For temperature measurement in liquid and gaseous fluids
- For pipeline installation
- Measuring element PT100, PT1000 or NTC
- Housing made of polycarbonate, pure white
- Ingress protection rating IP 65
- Measuring fluid max.: -50 ... +160 °C
- Several insertion lengths

page 216

baelz 25



Cable temperature sensor

- For temperature measurement in liquid and gaseous fluids
- Measuring element PT100
- Ingress protection rating IP 43 or IP 67
- Measuring fluid max.: -50 ... +180 °C
- Several insertion lengths

page 217

baelz 26



Duct temperature sensor

- For temperature measurement in ventilation ducts
- Measuring element PT100 or NTC
- Housing made of polyamide, pure white
- Ingress protection rating IP 65
- Measuring fluid max.: -50 ... +160 °C
- Insertion length 192 mm

page 217

baelz 27



Contact temperature sensor

- For temperature measurement on tubes
- Measuring element PT100 or NTC
- Housing made of polyamide, pure white
- Ingress protection rating IP 65
- Measuring fluid max.: -35 ... +120 °C
- Ambient temperature: -35 ... +90 °C

page 218

baelz 61**Immersion temperature sensor**

- For temperature measurement in liquid and gaseous fluids
- Measuring element PT100
- Connection head made of aluminum
- Ingress protection rating IP 66
- Measuring fluid: -50 ... +600 °C
- Ambient temperature: max. 100 °C
- Several insertion lengths

page 219

baelz 251**Stainless steel thermowell**

- For baelz 25 and baelz 61
- Made of stainless steel 1.4571
- Available as screw-in or weld-in thermowell
- For several sensor lengths

page 219

baelz 828**Pressure transmitter**

- Accuracy: $\leq 0.2\%$ at 25 °C
- Auxiliary voltage: 9 ... 30 V DC
- Output signal: 4 ... 20 mA, 2-wire
- Ingress protection rating IP 65
- Measuring fluid: -40 ... +100 °C (/125 °C)
- Ambient temperature: -25 ... +80 °C

page 220

baelz 1750**Conductivity electrode**

- For monitoring water quality
- Electrode housing and electrode rod made of stainless steel
- Ingress protection rating IP 65
- Operating pressure max. 32 bar
- Operating temperature max. 239 °C
- Available in 2 stem lengths

page 220

baelz 1753**Measuring and switching amplifier**

- For conductivity electrode baelz 1750
- Housing with snap-on mounting for mounting rail
- 1 limit contact max. 250 V AC, 5 A
- Current output: 4 ... 20 mA
- Voltage: 230 V \pm 10 %, 50/60 Hz, approx. 4.5 VA
- Ambient temperature: -0 ... 60 °C

page 221

baelz 1771**Bypass level sensor**

- Level indicator without auxiliary power
- Bypass tube and magnetic float made of stainless steel 1.4571
- Operating pressure max. 20 bar
- Operating temperature max. 200 °C
- Several designs available



baelz 22

DESCRIPTION

Room temperature sensor for temperature measurement in living spaces, offices, etc. For indoor wall mounting.

TECHNICAL SPECIFICATIONS

Housing: polycarbonate, pure white
 Ingress protection rating: IP 30
 Dimensions: 84.5 x 84.5 x 25 mm
 Weight, approx.: 0.05 kg

Ambient conditions:
 Temperature: -35 ... +70 °C
 Relative humidity: 0 ... 85%

Equipment and options, baelz 22

Type	Measuring element	Pushbutton	Rotary switch	Correction potentiometer	LED
22-PT	1 x PT100	max. 35 V DC, 10 mA	-	-	-
22-2PT	2 x PT100	-	-	-	-
22-PT-TL	1 x PT100	-	-	-	max. 24 V DC
22-PT-S	1 x PT100	-	0-I; max. 60 VAC, 5 VA	-	-
22-PT-2SL	1 x PT100	-	0-II; max. 60 VAC, 5 VA	-	max. 24 V DC
22-PT-P	1 x PT100	-	-	5 kΩ, 0.25 W, 3-wire	-
22-PT-PTL	1 x PT100	max. 35 V DC, 10 mA	-	5 kΩ, 0.25 W, 3-wire	max. 24 V DC
22-PT-PS	1 x PT100	-	0-I; max. 60 VAC, 5 VA	5 kΩ, 0.25 W, 3-wire	-
22-PT-PS2L	1 x PT100	-	0-II; max. 60 VAC, 5 VA	5 kΩ, 0.25 W, 3-wire	max. 24 V DC
22-3.2	1 x NTC	-	-	-	-
22/2-3.2	2 x NTC	-	-	-	-

baelz 23

DESCRIPTION

Outdoor temperature sensor. For outdoor wall mounting.

TECHNICAL SPECIFICATIONS

Housing: polycarbonate, pure white
 Ingress protection rating: IP 65
 Dimensions, approx.: 70 x 67 x 46 mm
 Cable gland: M16
 Weight, approx.: 0.1 kg

Ambient conditions:
 Temperature: -35 ... +90 °C
 Relative humidity: 0 ... 85%



Equipment, baelz 23

Type	Measuring element
23-PT	1 x PT100
23-2PT	2 x PT100
23-PT1000	1 x PT1000
23-2PT1000	1 x PT1000
23-3.1	1 x NTC

Note: Avoid direct exposure to rain condensation and sunlight when mounting outside.



baelz 24

DESCRIPTION

Immersion temperature sensor for temperature measurement in liquid and gaseous fluids. For pipeline installation.

TECHNICAL SPECIFICATIONS

Housing: polycarbonate, pure white
 Ingress protection rating: IP 65
 Cable gland: M16
 Screw-in part: SW24, G 1/2, stainless steel 1.4305
 Sensor sleeve: Ø 8 mm, 1.4571 (up to max. 16 bar)
 Head temperature: -35 ... +90 °C
 Measuring fluid PT100/1000: -50 ... +160 °C
 Measuring fluid NTC: -50 ... +140 °C
 Flow velocity: ≤ 2.5 m/s water; ≤ 15 m/s steam
 Insertion length: 50, 100, 150, 200 mm - see type designation

Equipment and options, baelz 24

Type	Measuring element	Insertion length (mm)	Weight. approx. (kg)
24-PT-50mm	1 x PT100	50	0.1
24-PT-100mm	2 x PT100	100	0.15
24-PT-150mm	1 x PT100	150	0.2
24-PT-200mm	1 x PT100	200	0.2
24-2PT-50mm	1 x PT100	50	0.1
24-2PT-100mm	1 x PT100	100	0.15
24-2PT-150mm	1 x PT100	150	0.2
24-2PT-200mm	1 x PT100	200	0.2
24-PT1000100mm	1 x PT100	100	0.15
24-PT1000-150mm	1 x NTC	150	0.2
24-PT1000-200mm	2 x NTC	200	0.2
24-3.3-50mm	1 x NTC	50	0.1
24-3.3-100mm	1 x NTC	100	0.15
24-3.3-150mm	1 x NTC	150	0.2
24-3.3-200mm	1 x NTC	200	0.2



baelz 25/4

DESCRIPTION

Cable temperature sensor for temperature measurement in liquid and gaseous fluids.

TECHNICAL SPECIFICATIONS

Measuring element:	1 x PT100
Ingress protection rating:	IP 43
Sensor sleeve:	Ø 4 x 100 mm, 1.4571
Connection pipe, length 5 m:	3 x 0.14 mm ² , PTFE
Flow velocity:	≤ 2.5 m/s water; ≤ 15 m/s steam
Incl. compression fitting 1.4571, G 1/4, SW17, PN 16, stainless steel cutting ring for Ø 4 mm	
Weight, approx.:	0.2 kg
Fluid/ambient temperature:	-80 ... +260 °C

baelz 25

DESCRIPTION

Cable temperature sensor for temperature measurement in liquid and gaseous fluids.

TECHNICAL SPECIFICATIONS

Measuring element:	1 x PT100
Ingress protection rating:	IP 43 or IP 67 (roller-burnished)
Sensor sleeve: Ø 6 mm, 1.4571; 100, 150 and 200 mm (up to max. 10 bar)	
Connection pipe, length 3 m or 5 m:	3 x 0.25 mm ² (standard) CY - with shielding 2L - 2 x 0.25 mm ²
Flow velocity:	≤ 2.5 m/s water; ≤ 15 m/s steam
incl. compression fitting G 1/4 - 1.4571	
Weight, approx.:	0.15 kg / pipe 3 m; 0.2 kg / pipe 5 m
Fluid/ambient temperature:	-35 ... +100 °C / PVC pipe -50 ... +180 °C / silicone pipe

Equipment and options, baelz 25 / baelz 25/4

Type	Sensor sleeve	Protection type	Cable
25-PT-100mm-PVC-CY-3m-IP43	100 mm	IP 43	3-wire, PVC CY, 3 m
25-PT-150mm-PVC-CY-3m-IP43	150 mm	IP 43	3-wire, PVC CY, 3 m
25-PT-200mm-PVC-CY-3m-IP67	200 mm	IP 67	3-wire, PVC CY, 3 m
25-PT-200mm-PVC-2L-3m-IP43	200 mm	IP 43	2-wire, PVC 2L, 3 m
25-PT-100mm-Sil.-3m-IP43	100 mm	IP 43	3-wire, silicone, 3 m
25-PT-200mm-Sil.-3m-IP67	200 mm	IP 67	3-wire, silicone, 3 m
25-PT-150mm-Sil.-5m-IP67	150 mm	IP 67	3-wire, silicone, 5 m
25/4-PT-100mm-PTFE-5m-IP43	100 mm	IP 43	3-wire, PTFE, 5 m

Accessories

Type	Description	Option
ZB25-26622	Adapter for socket connection G 1/2, material 1.4571 (reducing adapter from G 1/2 to G 1/4)	incl. sealing edge ring G 1/2, 1.4571 (for clean steam stations)
25-PZB25-26622 (Cu)	optionally with sealing edge ring or copper seal	incl. copper seal 23 x 21 x 2 mm



Equipment, baelz 26	
Type	Measuring element
26-PT	1 x PT100
26-2PT	2 x PT100
26-3.2	1 x NTC
26/2-3.2	2 x NTC

baelz 26

DESCRIPTION

Duct temperature sensor for temperature measurement in ventilation ducts

TECHNICAL SPECIFICATIONS

Connection head:	polyamide, pure white
Ingress protection rating:	IP 65
Cable gland:	M16
Sensor sleeve:	Ø 6 mm, 1.4571
Housing temperature:	-35 ... +70 °C
Measuring fluid:	-45 ... +130 °C
Flow velocity:	≤ 30 m/s air
Insertion length:	192 mm
Weight approx.:	0.1 kg

Accessories		
Type	Description	Notes
ZB26-MF-Ø7mm	Mounting flange for sensor sleeve from baelz 26, diameter: 7 mm, weight approx.: 0.04 kg	As replacement or for retrofitting Mounting flange included in baelz 26 delivery.

baelz 27



DESCRIPTION

Contact temperature sensor for temperature measurement on tubes

TECHNICAL SPECIFICATIONS

Housing:	polyamide, pure white
Ingress protection rating:	IP 65
Sensor sleeve:	brass
Ambient temperature:	-35 ... +70 °C (housing)
Measuring range:	-45 ... +130 °C
Dimensions:	65 x 50 mm
Suitable for all tube Ø up to 2"	
Weight approx.:	0.05 kg

Note: Tensioning strap and heat conducting paste included. For larger diameters, also order tensioning strap (see accessories).

Equipment, baelz 27	
Type	Measuring element
27/1-PT	1 x PT100
27/1-PT1000	1 x PT1000
27-3.3	1 x NTC

Accessories		
Type	Description	Notes
ZB27-SB-900mm	Tensioning strap for tube Ø > 2" Length: 900 mm, weight approx.: 0.05 kg	Heat conducting paste included



baelz 61

DESCRIPTION

Immersion temperature sensor for temperature measurement in liquid and gaseous fluids.

TECHNICAL SPECIFICATIONS

Measuring element: PT100, EN 60751 (IEC 751), Class B
 Ingress protection rating: IP 66
 Connection head: form B, aluminum
 Stem: Ø6 mm, 1.4571
 with sheathed cable (vibration resistant)
 2-wire circuit
 Cable gland: M20 x 1.5
 Compression fitting: G 1/4, 1.4571

Measuring range: -50 ... +600 °C
 Ambient temperature: max. 100 °C

Operating parameters, baelz 61

Length (mm)	Pressure (bar)	Fluid density (kg m ³ /h)	Flow velocity (m/s)
100/200	≤ 8	Air, gas, steam ≤ 5.5	60
300			30
400			30
600			30
100/200	≤ 40	Gas, steam ≤ 109	8.5
300			5
400			5
600			5
100/200	≤ 40	Liquid ≤ 800	3.2
300			2
400			2
600			2
100/200	≤ 40	Liquid ≤ 1000	2.5
300			1.8
400			1.8
600			1.8

Equipment and options, baelz 61

Type	Measuring element	Stem length (mm)	Weight approx. (kg)
61-1-100mm-VA	1 x PT100	100	0.45
61-1-200mm-VA	1 x PT100	200	0.55
61-1-300mm-VA	1 x PT100	300	0.55
61-1-400mm-VA	1 x PT100	400	0.55
61-1-600mm-VA	1 x PT100	600	0.7
61-2-200mm-VA	2 x PT100	200	0.55
61-2-300mm-VA	2 x PT100	300	0.55
61-2-400mm-VA	2 x PT100	400	0.55
61-2-600mm-VA	2 x PT100	600	0.7

Accessories

Type	Description	Notes
ZB61-MP	Mounting plate for air duct mounting baelz 61, with thread G 1/4	with soft seal for max. 80 °C, dimensions 60 x 60 mm, weight approx. 0.1 kg
ZB61-G1/2-VA	Reducer fitting G 1/2 - G 1/4	1.4571, weight approx. 0.05 kg
ZB61-G1/4-VA	Replacement fitting G 1/4	1.4571, weight approx. 0.05 kg



Equipment and options, baelz 251

Type	for sensor length (mm)	Weight approx. (kg)
251-S5-65mm-VA	100	0.3
251-S5-145mm-VA	200	0.4
251-S5-245mm-VA	300	0.45
251-S5-345mm-VA	400	0.5
251-S5-545mm-VA	600	0.7
251-S6-145mm-VA	200	0.4
251-S6-245mm-VA	300	0.45
251-S6-345mm-VA	400	0.5

baelz 251

DESCRIPTION

Thermowell made of stainless steel 1.4571 for temperature sensors baelz 25 and baelz 61. 251-S5 screw-in; 251-S6 weld-in.

TECHNICAL SPECIFICATIONS

Stainless steel screw-in thermowell baelz 251-S5

Connection: internal G 1/4, external G 1/2

Stainless steel weld-in thermowell baelz 251-S6

Connection : internal G 1/4

Max. flow velocity 251-S5 and 251-S6:

5 m/s in liquids

40 m/s in air, gas, steam

Max. pressure for an installation length of 145 mm:

at 50 °C 90 bar; at 400 °C 65 bar

Max. pressure for an installation length of 345 mm:

at 50 °C 40 bar; at 400 °C 30 bar

baelz 828

DESCRIPTION

Pressure transmitter

TECHNICAL SPECIFICATIONS

Accuracy: ≤ 0.2 % at 25 °C
 Auxiliary voltage: 9 ... 30 V DC
 Output signal: 4 ... 20 mA, 2-wire, short-circuit proof
 Electrical connection: plug EN175301-803A
 Process connection: G 1/2 A/DIN 16288, 1.4404
 Housing: 1.4404
 Measuring cell: ceramic Al₂O₃
 Process seal: FPM (Viton)
 Ingress protection rating: IP 65
 Fluid temperature: -40 ... +100 °C (125 °C < 0.5 h) - see note
 Ambient temperature: -25 ... +80 °C
 Weight approx.: 0.15 kg



Note: For higher temperatures we recommend a water seal, see baelz 85800.

Digital display on inquiry (ZB828-DA)

Equipment and options, baelz 828-N

Type	Measuring range	Overload limit
828-N-0,10N	-100 ... 100 mbar	-0.3 / 4 bar
828-N-0,20N	-200 ... 200 mbar	-1 / 6 bar
828-N-1N	-1 ... 1 bar	6 bar
828-N-3N	-1 ... 3 bar	25 bar
828-N-9N	-1 ... 9 bar	40 bar
828-N-0.10	0 ... 100 mbar	-1 / 4 bar
828-N-0.16	0 ... 160 mbar	-1 / 6 bar
828-N-0.20	0 ... 200 mbar	-1 / 6 bar
828-N-0.25	0 ... 250 mbar	-1 / 6 bar
828-N-0.40	0 ... 400 mbar	-1 / 6 bar
828-N-0.60	0 ... 600 mbar	-1 / 10 bar
828-N-1	0 ... 1 bar	-1 / 10 bar
828-N-1.6	0 ... 1.6 bar	-1 / 20 bar
828-N-2	0 ... 2 bar	-1 / 20 bar
828-N-2.5	0 ... 2.5 bar	-1 / 25 bar
828-N-4	0 ... 4 bar	-1 / 25 bar
828-N-6	0 ... 6 bar	-1 / 40 bar
828-N-10	0 ... 10 bar	-1 / 40 bar
828-N-16	0 ... 16 bar	-1 / 40 bar
828-N-20	0 ... 20 bar	-1 / 40 bar
828-N-25	0 ... 25 bar	-1 / 60 bar
828-N-40	0 ... 40 bar	-1 / 60 bar
828-N-60	0 ... 60 bar	-1 / 100 bar



baelz 1750

DESCRIPTION

Conductivity electrode for monitoring water quality.

TECHNICAL SPECIFICATIONS

Nominal pressure: PN 40
 Operating pressure: max. 32 bar
 Operating temperature: max. 239 °C
 Ambient temperature: plus 100 °C
 Electrode housing: stainless steel
 Electrode rod: stainless steel
 Insulator: PTFE
 Ingress protection rating: IP 65
 Mechanical connection: G 1/2
 Electrical connection: plug connector with terminal screws, strain relief, cable gland PG 11

Equipment and options, baelz 1750-5

Type	Stem length (mm)	Weight approx. (kg)
1750-5-340	340	0.8
1750-5-265	265	0.5
1750-5-150	150	0.3

Note: Sealing edge ring in stainless steel: Baelz type 70707-VA-G 1/2

baelz 1753

DESCRIPTION

Measuring and switching amplifier for conductivity electrode baelz 1750-5.

Housing with snap-on mounting for mounting rail.

TECHNICAL SPECIFICATIONS

Ingress protection rating: IP 40
 Dimensions (LxHxD): 51 x 112 x 111 mm
 1 limit contact: max. 250 V AC, 5 A
 Current output: 4 ... 20 mA
 Voltage: 230 V ± 10 %, 50/60 Hz, approx. 4.5 VA
 Manual temperature compensation
 Weight approx.: 0.5 kg
 Ambient temperature: 0 ... 60 °C

Note: The cable capacity must not exceed 1nF.



Equipment and options, baelz 1753-2

Type	Measuring range (µS/cm)	Adjustable limiting value at 25 °C (µS/cm)
1753-2-1000	0 ... 1000	100 ... 1000
1753-2-10000	0 ... 10000	1000 ... 10000

Accessories / Extra charges

Type	Description	Notes
ZB1753-CY3x0.75mm ² -5m (order No.) MP1753-022	Low capacitance connection cable BUS SAFETY CY 3 x 0.75 mm ² Extra charge per additional meter of cable	between baelz 1750 and 1753; length 5 m Max. Do not exceed a cable length of 20 m!



baelz 1771

DESCRIPTION

Bypass level sensor for continuous level indication without auxiliary power.

TECHNICAL SPECIFICATIONS

Bypass tube: stainless steel 1.4751, Ø 60.3 x 2 mm
 Magnetic float: stainless steel 1.4571 Ø 50 mm, length 185 mm
 Connection flange: DN 20, PN 40
 Operating pressure: max. 20 bar
 Operating temperature: max. 200 °C
 Drain plug: G 1/2 on lower flange (see note for option)
 Level sensor: resistance measuring chain approx. 0-5kΩ (measuring circuit 4.2)
 Measuring chain resolution: 5 mm

OPTIONS

ZMU 2-wire transmitter 1771-ZMU
 installed in the terminal housing of the sensor
 Ambient temperature: -20 ... +60 °C
 Output: 4 ... 20 mA
 Input: 0 ... 5 kΩ, 3-wire
 Load max.: 700 Ω at 24 V DC
 Supply: 11 ... 30 V DC

2BGU 2 magnetic contacts 1771-BGU
 Reed contact: bistable
 230 V AC, 60 VA, 1 A
 230 V DC, 30 W, 0.5 A
 Silicone cable 2 m (4 x 0.75 mm²)
 Arrangement of the magnetic switches:
 min. 30 mm from the center of the support

Equipment and options, baelz 1771-K

Type	Display	Center distance (mm)	With ZMU	With 2BGU	Weight approx. (kg)
1771-K-450	Without local display	450			15
1771-K-650		650			17
1771-K-850		850			19
1771-K-450-i	With magnetic roller display, aluminum housing and plastic rollers	450			15
1771-K-650-i		650			17
1771-K-850-i		850			19
1771-K-450-i-ZMU		450	✓		15.1
1771-K-450-i-ZMU-2BGU		450	✓	✓	15.8

Note: Also available with drain valve instead of drain plug. Order No. B1771-201
 Other resistance ranges on inquiry

Accessories / Extra charges, baelz 1771-K			
Type	Description	Notes	
MP1771-MRA-X	per 100 mm longer magnetic roller display	specify mm in place of X	
MP1771-BR-MG-X	per 100 mm longer bypass tube and sensor	specify mm in place of X	
ZB1771-ZMU	2-wire transmitter baelz 1771-ZMU installed in the terminal housing of the sensor	Ambient temperature: -20 ... +60 °C Output: 4 ... 20 mA Input: 0 ... 5 kΩ, 3-wire Load max.: 700 Ω at 24 V DC Supply: 11 ... 30 V DC Weight approx.: 0.04 kg	
ZB1771-BGU-2	Magnetic contact baelz 1771-BGU-2	Switching behavior: bistable Switching capacity: 230 V AC, 60 VA, 1 A 230 V DC, 30 W, 0.5 A with 2 m silicone cable (4 x 0.75 mm ²) for mounting on the magnetic roller display Weight approx.: 0.35 kg	
ZB1771-AV / DN 8, PN 400	Drain valve	Housing: 1.4571 Connection: G 1/2 external thread DN 8, PN 400 Weight approx.: 0.5 kg	
ZB1771-ZVSS250	Replacement magnetic float	Ø 50 mm, length 250 mm, weight approx. 0.4 kg	
ZB1771-ZVSS185	Replacement magnetic float	Ø 50 mm, length 185 mm, weight approx. 0.3 kg	
ZB1771-R250/ME450	Replacement magnetic roller display	Aluminum housing with plastic rollers	Center distance: 450 mm
ZB1771-R720/ME650	Replacement magnetic roller display		Center distance: 650 mm
ZB1771-R920/ME850	Replacement magnetic roller display		Center distance: 850 mm
ZB1771-ZMU-5000Ohm-ME450	Sensor with built-in transmitter for baelz 1771. Complete with stainless steel tube. Including 2-wire transmitter baelz 1771-ZMU installed in the terminal housing of the sensor.	Total resistance approx. 5000 Ω (measuring circuit 4.2, standard) Ambient temp.: -20 ... 60 °C Output: 4 ... 20 mA Input: 0 ... 5 kΩ, 3-wire Load max.: 700 Ω at 24 V DC Supply: 11 ... 30 V DC	Center dist.: 450 mm
ZB1771-ZMU-5000Ohm-ME650			Center dist.: 650 mm
ZB1771-ZMU-5000Ohm-ME850			Center dist.: 850 mm

page 225

baelz 69/1-OM



Frost protection monitor

- For temperature monitoring of air heaters against freezing
- Two designs
- Adjustment range: -18...+13 °C
- Ingress protection rating with cover plate: IP 44
- Electrical changeover contact: 16 A, 250 V
- Cable connection: M16 strain-relieved
- Weight approx.: 0.7 kg

page 226

baelz 231/2-J-W



Double thermostat "Pilot"

- TÜV type-tested
- Functions purely electromechanically
- Housing: plastic / die-cast aluminum
- Ingress protection rating: IP 54 - EN 60529
- Pressure resistance: up to 50 bar

page 227

baelz 239/3-J



Inline expansion thermostat "Pilot"

- DIN-registered safety temperature monitors
- Functions purely electromechanically
- Housing: plastic / die-cast aluminum
- Ingress protection rating: IP 54 - EN 60529
- Pressure resistance: up to 65 bar

page 228

baelz 831/2-fs



Diaphragm differential pressure switch

- For use in firing, ventilation and air conditioning technology
- Housing and cover: polycarbonate
- Diaphragm: NBR
- Setting tolerance: ± 15 %
- Ingress protection rating: IP 54
- Ambient temperature: -15...+60 °C
- Fluid temperature: -15...+70 °C
- Weight, approx.: 0.2 kg

page 229

baelz 834



Safety pressure switch

- TÜV-tested
- Sensor housing and wetted parts made of stainless steel
- Process connection: G ½ A, external thread
- Ingress protection rating: IP 54
- Max. fluid / ambient temp.: -25...+70 °C
- 1 changeover switch: 5 A, 250 V AC, inductive
- Weight, approx.: 0.6 kg

page 230

baelz 835/5



Pressure switch

- Housing: aluminum with transparent cover
- Ingress protection rating: IP 54
- Process connection: G ¾, internal
- Fluid temperature: +70 °C
- Ambient temperature: -20...+70 °C
- 1 changeover switch 16 A non-inductive, 6 A inductive max. 230 V AC
- Weight, approx.: 0.5 kg

page 231

baelz 779



Float switch

- For level monitoring
- Switching differential: 13 mm
- Switching contact: 1 NC contact, 1 NO contact
- Ambient temp.: max. 70 °C
- Ingress protection rating: IP 66
- Threaded cable gland: M20 x 1.5

page 232

baelz 783



Float switch

- For level monitoring
- Guide tube: 1.4571; Ø 12 mm
- Cylinder float: 1.4571; Ø 44 mm
- Process connection: G 1½; 1.4571
- max. -30...+120 °C / 16 bar
- Ingress protection rating: IP 65
- Switching capacity: 230 V AC; 100 VA; 1 A AC / 230 V DC; 50 W; 0.5 A DC
- Switching element: Reed switch

page 233

baelz 466

Controller

- With 4 or 6 input contacts
- For wall mounting

baelz 1781/5

Amplifier relay

- Can be used with baelz 1782-4 as sensor for interfaces



baelz 1782-4

Level probe

- No moving parts in the fluid
- max. -220 °C / 25 bar



page 234

baelz 1783/2



Duct smoke detector

- For controlling fans and for monitoring ventilation.
- VdS approved (G210059)
- Sensor: scattering RM 3.3 (ALK-E)
- Operating temperature: -20 °C - +50 °C
- Perm. flow: 1 - 20 m/s
- Ingress protection rating: IP 54
- Weight, approx.: 3 kg

page 235

baelz 740-S-E



Condensate pilot - High pressure centrifugal pumps

- Also as submersible pump
- Housing made of cast iron GJL-200
- Operating pressure max. 16 bar
- Neutral fluids - water, oils, etc.
- Ingress protection rating: IP 55

page 236

baelz 749

Pump controller

- For 1 or 2 condensate pumps
- up to max. 1.5 kW
- With fault alarm output
- Coating: RAL 7035, light gray
- Supply line: 400 V / 230 V, 50 Hz
- With motor-protective circuit-breaker, power protection, control fuse
- Control lamps: OPERATION / FAULT



baelz 69/1-OM

DESCRIPTION

Frost protection monitor for temperature monitoring of air heaters against freezing.

TECHNICAL SPECIFICATIONS

Steam-filled capillary with precise switching mechanism
 Adjustment range: -18...+13 °C
 Ingress protection rating with cover plate: IP 44
 Electrical changeover contact: 16 A, 250 V
 Cable connection: M16 strain-relieved
 Housing: sheet steel, nickel-plated
 Capillary tube length 6 m without reset, with 6 mounting clamps.
 Mounting plate, cover plate, capillary feed-through and the required mounting parts are included in the delivery.
 Weight approx.: 0.7 kg

baelz 69/1-OM-2P

DESCRIPTION

2-phase antifreeze monitor on air side with display for temperature monitoring of air heaters against freezing.

TECHNICAL SPECIFICATIONS

Display indicator: for operating mode and frost hazard
 Operating voltage: 24 V AC +10/-20 %, 50/60 Hz
 Power consumption: 6.6 VA
 Measuring range: 0...15 °C
 Adjustment range: 1...10 °C
 Switching differential: approx. 2 K
 Continuous output signal: 0...10 V max. 1 mA
 Continuous input signal: 0...10 V max. 1 mA
 Contact load max.: 6(2) A, 230 V AC, 6 A 24 V DC
 Contact load min.: 5 mA, 5 V AC/DC
 Factory setting: 5 °C
 Perm. apparatus head temp.: -15...+55 °C
 Ingress protection rating / class: IP 42, I
 Time constant: stationary air 90 s, moving air <40 s
 Capillary tube: perm. temperature max. 110 °C
 Electrical connection: spring terminals max. 2 x 1.5 mm² or 1 x 2.5 mm²
 Capillary tube length 6 m, with 6 mounting clamps.
 Threaded cable gland M16, rubber grommet and fixing screws are included in the delivery.
 Weight approx.: 0.8 kg





baelz 231/2-J-W

DESCRIPTION

The TÜV type-tested double thermostat "Pilot" functions purely electromechanically while being reliable and low-priced. It is used for decentralized temperature control as a controller, monitor or limiter.

STW = safety temperature monitor

STB = safety temperature limiter

TECHNICAL SPECIFICATIONS

Housing cover:	plastic
Lower part:	die-cast aluminum, painted
Ingress protection rating:	IP 54 - EN 60529
Cable gland:	M20 x 1.5
Sensor:	copper (Cu-DHP), Ø 6 mm
Ambient temperature:	thermostat head max. 80 °C
Media:	water, oil, hot steam, air
Connection:	G ½ screw-in spigot form A, DIN 3852/2 with fixing screw
Pressure resistance:	50 bar/100 °C 48 bar/150 °C 42 bar/250 °C
Screw-in thermowell:	Ø 15 x 0.75 mm, 150 or 300 mm stainless steel 1.4571
Switching differential:	STW: 4...6 % STB: internal manual reset
Contact type:	STW: changeover (fs) STB: changeover (fs) and restart lockout
Switching capacity max.:	AC 230 V +10 %, 10(2) A cos φ = 1 (0.6) DC 230 V +10 %, 0.25 A

Max. inflow velocity in m/s at 200 °C

Thermowell length →	150 mm	300 mm
Water	8.5	4.3
Oil	8.4	4.2
Air	42.9	21.5

Baelz type	Setpoint range (°C)	Max. sensor temp. (°C)	Thermowell (mm)	Weight. approx. (kg)
231/2-J-W-15-fs-VA-150	20...150	175	150 x Ø15	0.74
231/2-J-W-30-fs-VA-150	20...150	175	300 x Ø15	0.78
231/2-J-W-30-fs-VA-250	50...250	290	300 x Ø15	0.78



baelz 239/3-J

DESCRIPTION

The DIN-registered inline expansion thermostat "Pilot" functions purely electromechanically while being reliable and attractively priced. It is used for decentralized temperature control as a safety temperature monitor (STW).

TECHNICAL SPECIFICATIONS

Housing cover:	plastic
Lower part:	die-cast aluminum, painted
Ingress protection rating:	IP 54 - EN 60529
Cable gland:	M20 x 1.5
Sensor:	copper, Ø 6 mm
Ambient temperature:	thermostat head max. 80 °C
Media:	water, oil, hot steam, air
Connection:	G ½ screw-in spigot form A, DIN 3852/2
Pressure resistance:	65 bar/100 °C 60 bar/150 °C 55 bar/200 °C
Screw-in thermowell:	Ø 8 x 0.75 mm, length 300 mm stainless steel 1.4571 at temperatures above 150 °C with cooling adapter
Switching differential:	5 %
Contact type:	changeover switch (fs)
Switching capacity max.:	AC 230 V +10 %, 10(2) A cos φ = 1 (0.6) DC 230 V +10 %, 0.25 A

Max. inflow velocity in m/s at 200 °C

Thermowell length →	150 mm	300 mm
Water	4.4	2.9
Oil	4.3	2.9
Air	16.2	10.8

Baelz type	Setpoint range (°C)	Thermowell (mm)	Weight. approx. (kg)
239/3-J-30-fs-VA-200	50...200	300 x Ø8	0.6
239/3-J-15-fs-Mv-150	20...150	150 x Ø8	0.6

Note: Adapter for installation in existing thermowell baelz 251-S7 without draining the system, baelz 85939 - available on request.
For higher flow velocities we offer thermowells in special design. Please inquire!



baelz 831/2-fs

DESCRIPTION

Diaphragm differential pressure switch for differential pressure monitoring in firing, ventilation and air conditioning technology. It is suitable for switching a circuit on, off or over when the actual pressure value changes in relation to the setpoint.

TECHNICAL SPECIFICATIONS

Housing and cover:	polycarbonate
Diaphragm:	NBR
Setting tolerance:	± 15 %
Ingress protection rating:	IP 54
Ambient temperature:	-15...+60 °C
Fluid temperature:	-15...+70 °C (see note)
Fluid:	air, neutral, non-aggressive gases
Pressure connection:	2 hose nozzles Ø 4.6 mm or 2 hose nipples Ø 4.6 mm
Electrical connection:	terminal screws
Threaded cable gland:	PG11
1 changeover switch:	max. 250 V AC/3 A at cos φ = 0.6 max. 48 V DC/1 A
Weight, approx.:	0.2 kg

Baelz type	Max. operating pressure (mbar)	Adjustment range (mbar)	Switching differential (mbar)	Dimensions L x H x D approx. (mm)
831/2-fs-1.5	50	0.2...1.5	≤ 0.18	Ø 101 mm, depth 56 mm
831/2-fs-3	500	0.4...3	≤ 0.3	72 x 72 x 45.5
831/2-fs-50	500	2.5...50	≤ 1	72 x 72 x 45.5

Accessories		
Baelz type	Product	Weight. approx. (kg)
ZB831-LGW	Air duct connection nipple, 1 set (2 pieces)	0.05
ZB831-KS	Fixing bracket (snap bracket)	0.1

Note: For higher temperatures we recommend a water seal, see baelz 85800.



baelz 834

DESCRIPTION

The TÜV-tested safety pressure switches baelz 834 are suitable for pressure limitation and pressure monitoring in steam and hot water systems.

TECHNICAL SPECIFICATIONS

Sensor housing:	stainless steel 1.4104
Wetted parts:	metal bellows - stainless steel 1.4571
Switch housing:	die-cast aluminum GD-AISI12 (DIN 1725)
Process connection:	G ½ A, AG
Electrical connection:	plug DIN 43650
Ingress protection rating:	IP 54
Max. fluid / ambient temperature:	-25...+70 °C (see note)
1 changeover switch:	5 A, 250 V AC, inductive
Vacuum resistance:	-1 bar
Weight, approx.:	0.6 kg

Baelz type	Function	Adjustment range (bar)	Operating pressure (bar)	Switching differential (bar)
834/1-f-SDBAM6	Maximum pressure limitation	1.2...6	max. 10	Manual reset
834/1-f-SDBAM16	Maximum pressure limitation	3...16	max. 20	Manual reset
834/1-f-SDBAM32	Maximum pressure limitation	6...32	max. 45	Manual reset
834/2-fs-DWR6	Maximum and minimum pressure monitoring	0.5...6	max. 16	0.2 (not adjustable)
834/2-fs-DWR16	Maximum and minimum pressure monitoring	3...16	max. 25	0.5 (not adjustable)
834/2-s-DWR6/206	Minimum pressure limitation	0.5...6	max. 16	Manual reset
834/2-s-DWR16/206	Minimum pressure limitation	3...16	max. 25	Manual reset

Note: baelz 834/2-fs-DWR6 = replacement for baelz 834/2-f-DWUM8
 baelz 834/2-s-DWR6/206 = replacement for baelz 834/2-f-DBUM8
 For higher temperatures a water seal must be provided, see baelz 85830 / 85840. If a water seal is not possible due to lack of space, please ask us for further special designs.



baelz 835/5

DESCRIPTION

For monitoring and controlling the pressure of liquids and gases in pipelines, boilers, pressure vessels, water extinguishing systems and apparatus.

TECHNICAL SPECIFICATIONS

Housing lower part:	die-cast aluminum
Transparent cover:	impact-resistant polycarbonate sealable
Ingress protection rating:	IP 54
Process connection:	G 3/8, internal
Diaphragm measuring system	
Diaphragm:	Perbunan (mineral oil resistant)
Fluid temperature:	+70 °C
Ambient temperature:	-20...+70 °C
1 changeover switch	16 A non-inductive, 6 A inductive max. 230 V AC
Weight, approx.:	0.5 kg

Baelz type	Adjustment range (mbar)	Switching differential (mbar)	Dimensions LxHxD approx. (mm)
835/5-fs-2	0.11...2	0.11	103 x 105 x 78
835/5-fs-4	0.22...4	0.25	
835/5-fs-8	0.5...8	0.5	
835/5-fs-32	2...32	2.0	

Accessories

Baelz type	Product	Weight. approx. (kg)
ZB835-MVR	Manometer fitting, steel, external thread G 1/2 x G 3/8	0.05

Note: For higher temperatures we recommend a water seal, see baelz 85800.



baelz 779

DESCRIPTION

The flange and housing float switches baelz 779... are used for level monitoring.

TECHNICAL SPECIFICATIONS

Switching differential:	13 mm
Switching contact:	1 NC contact, 1 NO contact
Contact load AC:	max. 440 V AC/max. 5 A/max. 2000 VA at power factor = 0.4 min.
Contact load DC:	max. 240 V DC max. 1 A, 35 W inductive load max. 2 A, 70 W resistive load
Ambient temperature:	max. 70 °C
Ingress protection rating:	IP 66
Threaded cable gland:	M20 x 1.5 brass nickel-plated

Float switch with flange for side mounting baelz 779... Magnetic switch without stuffing box

Baelz type	Switch housing	Internal parts	Connection	Temp./Pressure max.	Weight. approx. (kg)
779	Aluminum bronze	Stainless steel	Square flanges 92 x 92 mm	200 °C/18 barg 20 °C/18 barg	3.5
779-2	Die-cast aluminum	Stainless steel	Square flanges 92 x 92 mm	350 °C/19.6 barg 200 °C/33.8 barg 20 °C/33.8 barg	3.5
779-3	Die-cast aluminum	Stainless steel	DN 80, PN 64, DIN 2636	350 °C/30 barg 120 °C/64 barg 20 °C/64 barg	9.5

Accessories

Baelz type	Product	Data / Notes	Weight. approx. (kg)
ZB779-A00	Square counter flanges for baelz 779 and 779-2	For installation in vessels Delivery includes M12 x 25 studs Dimensions 92 x 92 mm	1

Housing float switch baelz 779-G

Baelz type	With built-in Float switch	Housing	Screw bolts	Process connection	Temp./Pressure max.	Weight. approx. (kg)
779-G	baelz 779	Steel	Ck-35 - 1.1181	2 x DN 20, PN 40, DIN 2635	200 °C/18 barg 20 °C/18 barg	9.8
779-2-G	baelz 779-2	Steel	Ck-35 - 1.1181	2 x DN 20, PN 40, DIN 2635	350 °C/15.7 barg 180 °C/33.8 barg 20 °C/33.8 barg	9.8
779-3-G	baelz 779-3	Carbon steel (MR 856)	-	2 x DN 20, PN 64, DIN 2636	350 °C/30 barg 120 °C/64 barg 20 °C/64 barg	27.5



baelz 783

DESCRIPTION

Float switch for vertical installation for level monitoring.

TECHNICAL SPECIFICATIONS

Guide tube:	1.4571; Ø 12 mm
Cylinder float:	1.4571; Ø 44 mm
Process connection:	G 1½; 1.4571
Electrical connection:	aluminum housing 75 x 80 x 57 mm
Temperature / Pressure:	max. -30...+120 °C/16 bar
Ingress protection rating:	IP 65
Switching capacity:	230 V AC; 100 VA; 1 A AC 230 V DC; 50 W; 0.5 A DC
Switching element:	Reed switch
Contacts close when level rises	

baelz 783 - Contacts: 2 NO contacts

Baelz type	Insertion length (mm)	Switching points (mm)		Weight, approx. (kg)
		top	bottom	
783-520-180-470	520	180	470	1
783-600-200-500	600	200	500	1.05
783-1000-200-950	1000	200	950	1.25
783-1100-200-1000	1100	200	1000	1.3

baelz 783-1 - Contacts: 3 NO contacts

Baelz type	Insertion length (mm)	Switching points (mm)			Weight, approx. (kg)
		top	middle	bottom	
783-1-520-180-400-470	520	180	400	470	1
783-1-1000-200-900-950	1000	200	900	950	1.25

baelz 783-4 - Contacts: 4 NO contacts

Baelz type	Insertion length (mm)	Switching points (mm) specify when ordering				Weight, approx. (kg)
		S1 (top)	S2	S3	S4 (bottom)	
783-4-500-S1.../S2.../S3.../S4...	500	min. 55	Please specify desired switching points (S1-S4) when ordering		max. 450	1
783-4-1000-S1.../S2.../S3.../S4...	1000	min. 55			max. 950	1.25

Note: Switching points measured from screw-in thread downwards.
Provide suitable contact protection measures to protect the reed contacts, see accessories.

Extra charges / Accessories

Baelz type	Product	Data
MP783-L-X	Per 100 mm longer insertion length. Specify length in place of X	-
ZB783-RC/24	RC elements for protective circuitry of reed contacts with inductive load on AC voltage	24 V
ZB783-RC/115		115 V
ZB783-RC/230		230 V



Note: Amplifier relays for potentially explosive atmospheres available on inquiry (baelz 1781-Ex).

baelz 1781/5

DESCRIPTION

Amplifier relay baelz 1781/5 can be used with level probe baelz 1782-4 as electronic sensor for interfaces, e.g. water steam and condensate.

TECHNICAL SPECIFICATIONS

Input:	control circuit electrode 6 V
Response sensitivity adjustable from:	1...150 kΩ = 1 mS...6.67μS
Output:	2-pole potential-free changeover contact 250 V / 2 A
Supply:	230 V, 50/60 Hz
Switch cabinet installation:	on standard rails according to DIN 46277
Dimensions (LxHxD):	22.5 x 75 x 99 mm
Weight, approx.:	0.2 kg

baelz 1782-4

DESCRIPTION

Level probe baelz 1782-4 can be used with amplifier relay baelz 1781/5. No floats, i.e. no moving parts in the fluid, no sticking, e.g. due to corrosion.

TECHNICAL SPECIFICATIONS

Material:	stainless steel 1.4571
Head:	light metal die-cast
Ingress protection rating:	IP 54
Connection:	G ½
Electrode length:	100, 200, 250 or 300 mm
Threaded cable gland:	PG 16
Fluid temperature:	max. 220 °C
Pressure:	max. 25 bar
For liquids with a minimum conductivity of 7 μS/cm	



Baelz type	Electrode length (mm)	Weight. approx. (kg)
1782-4-100	100	0.6
1782-4-200	200	0.7
1782-4-250	250	0.75
1782-4-300	300	0.8

Accessories

Baelz type	Product	Weight
ZB1782-KT24914	Enclosed socket 1/2 x 76 mm	approx. 0.07 kg



baelz 1783/2

DESCRIPTION

Duct smoke detector for controlling fans and for monitoring ventilation. VdS approved (G210059).

TECHNICAL SPECIFICATIONS

Sensor: scattering RM 3.3 (ALK-E)
 Relay outputs: potential-free
 Alarm relay locked: 1 changeover contact, 8 A, 250 V AC or 24 V DC 1 NC contact, 8 A, 250 V AC or 24 V DC
 Contamination relay: 1 NC contact, 6 A, 250 V AC or 24 V DC
 Operating temperature: -20 °C - +50 °C
 Perm. flow: 1 - 20 m/s
 Perm. humidity: 10 - 95 % non-condensing
 Ingress protection rating: IP 54
 LED display: contamination level, flashes > 70 % for status indication
 LED in housing: for status indication
 Housing: ABS
 Air measuring tube: aluminum/plastic
1783/2-16... Length 160 mm
1783/2-60... Length 600 mm
Power supply: 230 V AC ± 10 %, 50/60 Hz or 24 V AC (16...27.6 V AC) 24 V DC (21.6...27.6 V DC)
 Rated current: 230 V AC: 30 mA 24 V AC/DC: 120 mA
 Threaded cable gland: 3 x M16
 Weight, approx.: 3 kg

Baelz type	Power supply	Length (mm)
1783/2-16-230VAC	230 V AC	160
1783/2-60-230VAC	230 V AC	600
1783/2-16-24VAC/DC	24 V AC/DC	160
1783/2-60-24VAC/DC	24 V AC/DC	600

Note: Modbus and BACnet interface on inquiry.

baelz 466

DESCRIPTION

Controller with 4 or 6 input contacts for wall mounting.

TECHNICAL SPECIFICATIONS

Housing: plastic
 Ingress protection rating: IP 40
 Voltage: 230 V, 50/60 Hz
 Control voltage: 24 V DC
 NC contact: 250 V / 1 A
 Dimensions: (LxHxD) 75 x 150 x 106 mm
 Weight, approx.: 0.8 kg

Baelz type	Control circuit	Output
466-4/4	4 input contacts	4 potential-free NO contacts
466-6/3	6 input contacts	3 potential-free NO contacts



baelz 740-CR

DESCRIPTION

Vertical high pressure centrifugal pumps available in many designs. Designed for durability under high pressure loads.

TECHNICAL SPECIFICATIONS

Housing: cast iron GJL-200 - 5.1300
 Impeller, shell,
 intermediate chamber: 1.4301
 Shaft 740-CR-1...CR-5: 1.4401
 Shaft 740-CR-10: 1.4057
 Cartridge mechanical seal, maintenance-free silicon carbide/silicon carbide, elastomers in EPDM
 Operating pressure: max. 16 bar
 Fluid temperature: 0...+120 °C
 Media: neutral fluids: water, oils, etc.
 Ambient temperature: max. +40 °C
 Ingress protection rating: IP 55
 Connection: oval flanges, internal thread connections on one level

Note: The maximum inlet pressures must not be exceeded, otherwise the motor bearings will be loaded with excessive axial forces for which they are not designed. The baelz 740-CR model is well suited to this purpose...F-L with additional bearing flange (on inquiry). Even then, the inlet pressure and zero delivery pressure must not exceed the maximum operating pressure.

Baelz type	Motor power (kW)	Max. inlet pressure (bar)	Nominal flow rate (m³/h)	Nominal head (mWs)	Weight, approx. (kg)	Connection
740-CR-1-11	0.55	10	1.8	51	22.5	Rp 1
740-CR-3-9	0.75	10	3	42	23.2	Rp 1
740-CR-5-8	1.1	10	5.8	39	26.2	Rp 1¼
740-CR-10-4	1.5	6	10	31.5	45	Rp 2
740-CR-10-8	3	7.5	10	64.5	55	Rp 1½

baelz 740-S-E

DESCRIPTION

Condensate pilot as submersible pump baelz 740-S-E... For installation in condensate tank baelz 128-E. Self-priming, vertical submersible centrifugal pump in sectional design made of chrome nickel steel.

TECHNICAL SPECIFICATIONS

Pump housing: cast iron GJL-200 - 5.1300
 Shaft sealing: carbide/carbide, FPM
 Operating pressure: max. 16 bar
 Fluid temperature: -10...+90 °C
 Media: neutral fluids: water, oils, etc.
 Ambient temperature: max. +40 °C
 Ingress protection rating: IP 55
 Connection: G ¾ internal thread
 Immersion depth: 518 mm

Rated current table baelz 740

Baelz-740-	Voltage	Rated current (A)
S-E-1-4-37	3 x 220...240 V / 380...415 V, 50 Hz	1.74 / 1.0
S-E-2-4-75	3 x 220...240 V / 380...415 V, 50 Hz	3.3 / 1.9
CR-1-11...	3 x 220...240 V / 380...415 V, 50 Hz	2.5 / 1.44
CR-3-9...	3 x 220...240 V / 380...415 V, 50 Hz	3.3 / 1.9
CR-5-8...	3 x 220...240 V / 380...415 V, 50 Hz	4.95 / 2.85
CR-10-4...	3 x 220...240 V / 380...415 V, 50 Hz	5.45 / 3.15
CR-10-8...	3 x 380...415 V Δ, 50 Hz	6.3
CR-15-3...	3 x 380...415 V Δ, 50 Hz	6.3
CR-15-4...	3 x 380...415 V Δ, 50 Hz	7.9

Note: Other models, e.g. other fluids or connections on inquiry.

Baelz type	740-S-E-2-4-75	740-S-E-1-4-37
Motor power (kW)	0.75	0.37
Nominal flow rate (m³/h)	4	2
Nominal head (mWs)	29.5	31
Weight, approx. (kg)	16	15

baelz 749

DESCRIPTION

Pump controllers **baelz 749/1-SEG** for 1 condensate pump
baelz 749/2-SEG for 2 condensate pumps
 up to max. 1.5 kW, with fault alarm output.

TECHNICAL SPECIFICATIONS

Pump capacity: X kW (please specify when ordering)
 Coating: RAL 7035, light gray
 Door hinge: right
 Threaded cable gland: bottom
 Supply line: 400 V / 230 V, 50 Hz
 With motor-protective circuit-breaker, power protection, control fuse
 Control lamps: OPERATION / FAULT

Baelz type	Sheet steel housing LxHxD (mm)	Switch	Weight. ap- prox. (kg)	Notes
749/1-SEG-X	300 x 300 x 155	MANUAL / OFF / AUTO	4	-
749/2-SEG-X	380 x 300 x 210	OFF / AUTO / P1 / P2	7	Pump change to auto position in case of restart or fault

Note: When ordering, please indicate pump capacity in kW in place of "X" in the type number.

2-way flanged isolating valve baelz 70023	238
2-way flanged isolating valve baelz 70027	240
2-way flanged isolating valve baelz 70028	242
2-way isolating valve with bellows seal baelz 70029	244
2-way isolating valve with bellows seal baelz 70029	245
Manometer isolating valve baelz 70075 / Valve block baelz 70079	246
Flanged check valve baelz 70081	247
Clamp-on check valve baelz 70082	249
Wafer-type check valve baelz 70084	250
Regulating and isolating valve baelz 70098-CL	252
Balancing and isolating valve baelz 70098/2	253
Stainless steel flanged ball valve baelz 70171-B-VA	254
Butterfly valve baelz 70195	255
Strainer baelz 70200Rg	256
Strainer baelz 70200-R-GL	257
Strainer baelz 70200-R-GS	258
Strainer baelz 70200-R-GP	259
Strainer baelz 70200-R-VA	260
Float steam trap with level control baelz 70310-H	261
Bimetallic steam trap baelz 70311-H	262
Condensate controller baelz 70315 / 70316	263
Flow sight glasses baelz 70317	264
Spring-loaded diaphragm high performance safety valve baelz 70341	265
2-way socket valve baelz 70500	266
Flow measurement and regulating valve baelz 70512	267
Backflow preventer baelz-hydrodyn CALEFFI baelz 70574	268
Ball valve baelz 70580-1	269
Stainless steel ball valve baelz 70580-B-VA	270
Diaphragm safety valve baelz 70625	271
Diaphragm safety valve baelz 70625H	272
Safety valve baelz 70625-H4	273
Safety valve baelz 70625-VA	274
Connection spigots baelz 70700A / Clamping sleeves baelz 70700M	275
Manometer tubes baelz 70701S-AG / baelz 70702S-AG	276
Comb-profiled seal baelz 70703 / Sealing discs baelz 70705 / Fluid level indicators baelz 70730	277
Duran glass tubes baelz 70749 / Stainless steel vent valve baelz 70798-VA	278
Bourdon tube manometers baelz 70802 / baelz 70804	279
Bourdon tube manometer baelz 70806-VA /	280
Bimetallic dial thermometer baelz 71150-TM-VA	280
Blind flange baelz 80000	281
Welding neck flange baelz 80300	282
Welding neck flange set baelz 80600	283
Welding neck flange set baelz 80700	284
Graphite seal HotFit baelz 80900	285
Hexagon bolts with nuts baelz 81100	286
Stainless steel hexagon bolts with nuts baelz 81101	287
Steel pipe elbow baelz 81200 / 81300	288
Tee fittings baelz 81500	289
Reducers baelz 81600	290
Reducers baelz 81600/1	291
Dished ends baelz 81900	292
Water seals baelz 85850 / 85892	293
baelz 85950 stuffing box heating	294

The exact product identification for the valves in this chapter is compiled as explained on page 4 of this catalogue.



baelz 70023

DESCRIPTION

The baelz 70023 is a 2-way flanged isolating valve for industrial applications.

TECHNICAL SPECIFICATIONS

Material: cast steel or stainless steel

Working fluids for cast steel: gases, water, steam and other non-aggressive fluids

Working fluids for stainless steel: gases, water, stainless steel, food, beverages, aggressive fluids

Plug types: shut-off plug, balancing plug, throttling plug, flat plug

Can be used down to -10 °C

Materials baelz 70023

	70023...	70023...-VA
Housing	up to DN 40: P250GH - 1.0460	from DN 50: GP2410GH+N - 1.0619+N GX5CrNiMo19-11 - 1.4408
Spindle	X20Cr13 - 1.4021	
Plug	up to DN 100: X20Cr13 - 1.4021	from DN 125: P250GH - 1.0460 X5CrNiMo18-10 - 1.4401
Spindle sealing	Stuffing box	
Stuffing box packing	Graphite	Flexible graphite

Baelz type	Equipment
70023	Shut-off plug
70023E	Balancing plug
70023R	Throttling plug, position indicator and locking device
70023R-VA	Throttling plug
70023-VA	Flat plug
70023-V+R	Shut-off plug, inlet/outlet: male/female
Additional option	70023-VA with throttling plug from DN 125 and position indicator on inquiry

Operating parameters

Baelz type	Nominal pressure	Tmax. / Pmax.	Operating pressure
70023 70023E 70023R 70023-V+R	PN 25 / 40	PN 25: 450 °C/8.2 bar - 350 °C/16 bar 250 °C/19 bar - 50 °C/25 bar PN 40: 450 °C/13.1 bar - 350 °C/25.7 bar 250 °C/30.4 bar - 50 °C/40 bar	max. 25 or 40 bar
70023R-VA 70023-VA	PN 10 / 16 / 25 / 40	PN 16: 400 °C/10.9 bar - 350 °C/11.4 bar 250 °C/12.7 bar - 20 °C/16 bar PN 40: 400 °C/27.4 bar - 350 °C/28.5 bar 250 °C/31.8 bar - 20 °C/40 bar	max. 16 or 40 bar

Max. permissible differential pressures for shut-off (bar)				
Baelz type	DN 125	DN 150	DN 200	Note
70023 70023E 70023R 70023-V+R	33	21	14	The differential pressures specified here are limited by the nominal pressure of the housing if lower. If the max. permissible differential pressures for shut-off specified for DN 125 to DN 200 are exceeded, valves with balancing plug, baelz 70023E, are required.
70023R-VA 70023-VA	33	21	-	If the max. permissible differential pressures for shut-off specified for DN 125 and 150 are exceeded, a balancing plug is required. Price on inquiry.

Nominal sizes, nominal pressures and weights baelz 70023, 70023E, 70023R, 70023-V+R													
DN	15	20	25	32	40	50	65	80	100	125	150	200	
PN	25/40	25/40	25/40	25/40	25/40	25/40	25/40	25/40	25/40	25/40	25/40	25	40
Weight approx. (kg)	4.3	5.5	6.2	9.6	10.5	13.5	21.3	33.3	46	68	95	159	175

Nominal sizes, nominal pressures and weights baelz 70023R-VA, 70023-VA																
DN	70023R-VA										70023-VA					
	15	20	25	32	40	50	65		80		100		125		150	
PN	10/40	10/40	10/40	10/40	10/40	10/40	10/16	25/40	10/16	25/40	10/16	25/40	10/16	25/40	10/16	25/40
Weight approx. (kg)	6.6	7.7	9.9	13.2	15.4	20.9	27.3	30.8	37	38.5	50.4	59.4	75.9	75.9	100	105.6

Kvs value (m³/h) baelz 70023...													
DN	15	20	25	32	40	50	65	80	100	125	150	200	
70023 / 70023-V+R	3.3	5.5	9.1	19	30	46	70	125	169	260	360	685	
70023E	-	-	-	-	-	-	-	-	-	260	360	PN 25: 685 PN 40: 680	
70023R	3.4	5.6	8.5	18	28	44	70	128	168	260	365	670	
70023R-VA	7	9	13	21	27	34	60	85	112	-	-	-	
70023-VA	-	-	-	-	-	-	-	-	-	243	364	-	

Dimensions baelz 70023...					
PN	DN	L (mm)	D (mm)	H ¹⁾ (mm)	H _{SS} ²⁾ (mm)
10/40 / 25/40	15	130	95	220	190
10/40 / 25/40	20	150	105	230	190
10/40 / 25/40	25	160	115	230	195
10/40 / 25/40	32	180	140	280	210
10/40 / 25/40	40	200	150	285	220
10/40 / 25/40	50	230	165	300	230
10/16 / 25/40	65	290	185	348	280
10/16 / 25/40	80	310	200	405	290
10/16 / 25/40	100	350	235	457	385
10/16 / 25/40	125	400	270	515	410
10/16 / 25/40	150	480	300	540	500
25	200	600	360	680	635
40	200	600	375	680	635

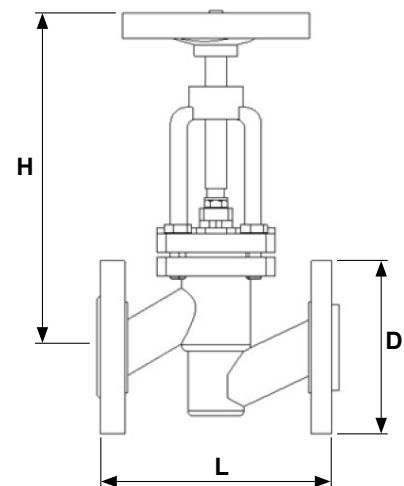

- 1) H for cast steel version (open)
- 2) H for stainless steel version (closed)



baelz 70027

DESCRIPTION

The baelz 70027 is a maintenance-free 2-way flanged isolating valve for industrial applications. It is equipped with a bellows seal.

TECHNICAL SPECIFICATIONS

Material: gray cast iron or stainless steel

Working fluids for gray cast iron: water, steam, thermal oil

Working fluids for stainless steel: general industry, food, beverages, aggressive media

Plug types: throttling plug, flat plug

Metal-to-metal seal

Can be used down to -10 °C

Materials baelz 70027...

	70027...	70027...-VA
Housing	GJL-250 - 5.1301	GX5CrNiMo19-11-2 - 1.4408
Spindle	Stainless steel	X5CrNiMo18-10 - 1.4401
Bellows seal and plug	Stainless steel	X6CrNiMoTi17-12-2 - 1.4571
Spindle sealing	Bellows seal (1.4541) and safety gland	2-walled bellows seal and safety gland
Stuffing box packing	Pure graphite	Flexible graphite

Baelz type	Equipment		Additional option		
70027R	Throttling plug up to DN 300	Flanged connection, DIN EN 1092-2, flange type 21	With position indicator, stroke limitation and locking device	Non-rising hand wheel	At operating temperatures > 200 °C and with uninsulated valves, the model with high temperature coating must be used - on inquiry
70027R-F	Flat plug: option from DN 125				
70027R-VA	Throttling plug up to DN 100		With position indicator	Non-rotating spindle with non-rising hand wheel	Throttling plug from DN 125 and locking device on inquiry
70027-VA	Flat plug DN 125, DN 150				

Operating parameters

Baelz type	Nominal pressure	Tmax. / Pmax.	Operating pressure
70027R 70027R-F	PN 16	PN 16: 300 °C/9.6 bar - 250 °C/11.2 bar -10...+120 °C/16 bar Steam: max. 200 °C/10 bar	max. 16 bar
70027R-VA 70027-VA	PN 10 / 16 / 25 / 40	PN 16: 400 °C/10.9 bar - 250 °C/12.7 bar 20 °C/16 bar PN 40: 400 °C/27.4 bar - 250 °C/31.8 bar 20 °C/40 bar	max. 16 or 40 bar

Max. permissible differential pressures for shut-off (bar)				
Baelz type	Nominal size / max. differential pressure			Note
70027R 70027R-F	DN 200: 12 bar	DN 250: 9 bar	DN 300: 6 bar	If the max. permissible differential pressures for shut-off specified for DN 200 to 300 are exceeded, a balancing plug is required. Price on inquiry.
70027R-VA 70027-VA	DN 125: 33 bar	DN 150: 21 bar	-	If the max. permissible differential pressures for shut-off specified for DN 125 and 150 are exceeded, a balancing plug is required. Price on inquiry.

Nominal sizes and weights baelz 70027R, 70027R-F - PN 16														
DN	15	20	25	32	40	50	65	80	100	125	150	200	250	300
Weight approx. (kg)	3.1	4	4.7	7.3	7.7	10.2	17	22	32	54	70.5	130	230	328

Nominal sizes, nominal pressures and weights baelz 70027R-VA, 70027-VA																
DN	70023R-VA											70023-VA				
	15	20	25	32	40	50	65		80		100		125		150	
PN	10/40	10/40	10/40	10/40	10/40	10/40	10/16	25/40	10/16	25/40	10/16	25/40	10/16	25/40	10/16	25/40
Weight approx. (kg)	4	4.7	6.3	7.9	10	14	19	24	24	28	37	42	27	62	81	102

Kvs value (m³/h) baelz 70027...														
DN	15	20	25	32	40	50	65	80	100	125	150	200	250	300
70027R	4.8	8.3	11.9	19.9	27.1	43.3	75.1	116.7	172.3	171.5	204	457	714	1028
70027R-F	-	-	-	-	-	-	-	-	-	270	393	657	1035	1466
70027R-VA	7	9	13	21	27	34	60	85	112	-	-	-	-	-
70027-VA	-	-	-	-	-	-	-	-	-	243	364	-	-	-



baelz 70028

DESCRIPTION

The baelz 70028 is a maintenance-free 2-way flanged isolating valve for industrial applications. It is equipped with a bellows seal.

TECHNICAL SPECIFICATIONS

Material: spheroidal iron
 Working fluids: water, steam, thermal oil
 Plug types: throttling plug, flat plug
 Metal-to-metal seal
 With position indicator, stroke limitation and locking device
 Can be used down to -10 °C

Materials baelz 70028...

Housing	GJS-400-18-LT - 5.3103
Internal parts	Stainless steel
Spindle sealing	Bellows seal (1.4541) and safety gland
Stuffing box packing	Pure graphite

Baelz type	Equipment			Additional option	
baelz 70028R	Throttling plug up to DN 300	Flanged connection, DIN EN 1092-2, flange type 21	With position indicator, stroke limitation and locking device	Non-rising hand wheel	At operating temperatures > 200 °C and with uninsulated valves, the model with high temperature coating must be used - on inquiry
baelz 70028R-F	Flat plug: option from DN 125				
baelz 70028AR	Throttling plug up to DN 150				
baelz 70028AR-F	Flat plug: option from DN 125				

Operating parameters

Baelz type	Nominal pressure	Tmax. / Pmax.	Operating pressure
70028R 70028R-F	PN 16	350 °C/11.2 bar - 250 °C/13.9 bar -10...+120 °C/16 bar	max. 16 bar
70028AR 70028AR-F	PN 25	350 °C/17.5 bar - 250 °C/21.8 bar -10...+120 °C/25 bar	max. 25 bar

Max. permissible differential pressures for shut-off (bar)

	Nominal size / max. differential pressure			Note
	DN 200:	DN 250:	DN 300:	
70028R 70028R-F	12 bar	9 bar	6 bar	If the max. permissible differential pressures for shut-off specified for DN 200 to 300 are exceeded, a balancing plug is required. Price on inquiry.
70028AR 70028AR-F	21 bar	-	-	If the max. permissible differential pressure for shut-off specified for DN 150 is exceeded, a balancing plug is required. Price on inquiry.

Nominal sizes and weights baelz 70028R, 70028R-F - PN 16

DN	15	20	25	32	40	50	65	80	100	125	150	200	250	300
Weight approx. (kg)	3.1	4.1	4.6	8.1	8.5	11	17	21	31	51	68.5	139	239	343

Nominal sizes and weights baelz 70028AR, 70028AR-F - PN 25

DN	15	20	25	32	40	50	65	80	100	125	150
Weight approx. (kg)	3.1	4.1	4.6	8.2	8.5	11	17	28.9	40	65	89

Kvs value (m³/h) baelz 70028...

DN	15	20	25	32	40	50	65	80	100	125	150	200	250	300
70028R	4.8	8.3	11.9	19.9	27.1	43.3	75.1	116.7	172.3	171.5	204	457	714	1028
70028R-F	-	-	-	-	-	-	-	-	-	270	393	657	1035	1466
70028AR	4.8	8.3	11.9	19.9	27.1	43.3	75.1	116.7	172.3	171.5	204	-	-	-
70028AR-F	-	-	-	-	-	-	-	-	-	270	393	-	-	-



baelz 70029

DESCRIPTION

The baelz 70028 is a 2-way flanged isolating valve with bellows seal for industrial applications.

TECHNICAL SPECIFICATIONS

Material: Cast steel (1.0460 or 1.0619+N)

Working fluids: water, steam, gases, thermal oil and other non-aggressive fluids

Plug types: shut-off plug, throttling plug

Can be used down to -10 °C

Materials baelz 70029

Housing	up to DN 40: P250GH - 1.0460	from DN 50: GP2410GH+N - 1.0619+N
Spindle	X20Cr13 - 1.4021	
Plug	up to DN 100: X20Cr13 - 1.4021	from DN 125: P250GH - 1.0460
Spindle sealing	Double-walled bellows seal and safety gland	
Stuffing box packing	Graphite	

Baelz type

Equipment

70029	Shut-off plug
70029R	Throttling plug, position indicator
70029-V+R	Shut-off plug, inlet/outlet: male/female

Operating parameters

Baelz type	Nominal pressure	Tmax. / Pmax.	Operating pressure
70029 70029R 70029-V+R	PN 25 / 40	PN 25: 450 °C/8,2 bar - 350 °C/16 bar 250 °C/19 bar - 50 °C/25 bar PN 40: 450 °C/13,1 bar - 350 °C/25,7 bar 250 °C/30,4 bar - 50 °C/40 bar	max. 25 / 40 bar

Max. permissible differential pressures for shut-off (bar)				
Baelz type	DN 125	DN 150	DN 200	Note
70029 70029R 70029-V+R	33	21	14	If the max. permissible differential pressure for shut-off specified for DN 125 to 200 is exceeded, a balancing plug is required. Price on inquiry.

Nominal sizes and weights baelz 70029, 70029R, 70029-V+R													
DN	15	20	25	32	40	50	65	80	100	125	150	200	
PN	25/40	25/40	25/40	25/40	25/40	25/40	25/40	25/40	25/40	25/40	25/40	25	40
Weight, approx. (kg)	3,3	4,8	5,4	9,1	10,2	13,2	19,8	27	41,7	66	88	144,6	175

Kvs value (m³/h) baelz 70029...													
DN	15	20	25	32	40	50	65	80	100	125	150	200	
70029 / 70029-V+R	3	5	8	15	42	52	70	125	160	260	350	650	
70029R	2,9	4,9	7,8	15	25	39	62	76	114	144	204	335	

Dimensions baelz 70029...				
PN	DN	L (mm)	D (mm)	H ¹⁾ (mm)
25/40	15	130	95	140
25/40	20	150	105	165
25/40	25	160	115	165
25/40	32	180	140	190
25/40	40	200	150	200
25/40	50	230	165	220
25/40	65	290	185	270
25/40	80	310	200	305
25/40	100	350	235	345
25/40	125	400	270	395
25/40	150	480	300	430
25	200	600	360	500
40	200	600	375	500

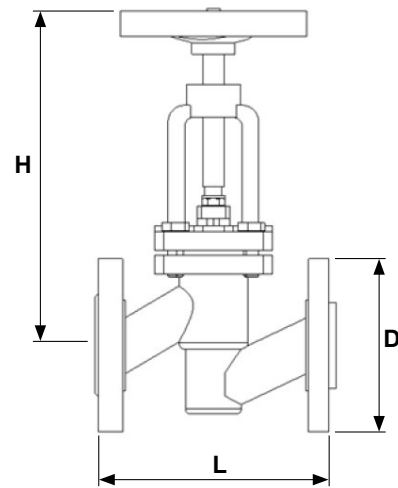

1) open



baelz 70075

DESCRIPTION

The baelz 70075 is a DIN 16720/A compliant manometer isolating valve for industrial applications.

TECHNICAL SPECIFICATIONS

Material: forged steel or stainless steel

Working fluids for forged steel: liquid, non-aggressive fluids, thermal oil

Working fluids for stainless steel: drinking water, liquid gaseous and aggressive fluids, thermal oil

Silicone-free model

Materials baelz 70075...

	70075		70075-VA-TW	
Housing	P250GH	1.0460	X6CrNiMoTi17-12-2	1.4571
Vent screw	X6CrNiMoTi17-12-2	1.4571	X6CrNiMoTi17-12-2	1.4571
Packing	Graphite		O-ring PTFE	
Stuffing box	11SMn30	1.0715	X6CrNiMoTi17-12-2	1.4571
Hand wheel	Ø 63 mm, plastic black		Ø 63 mm, plastic black	

Data and operating parameters

Baelz type	Nominal size, nominal pressure	Tmax. / Pmax.	Input	Output	Weight approx. (kg)
70075	DN 4, PN 400	400 °C/160 bar -10...+120 °C/400 bar	Spigot G ½ A, DIN EN 837-1	Spigot with clamping sleeve G ½ DIN 16283, steel - 1.0715	0.5
70075-VA-TW		-40...+200 °C/100 bar -40...+120 °C/100 bar	Spigot G ½ B, DIN EN 837-1	Spigot LH with clamping sleeve G ½ LH/RH DIN 16283, stainless steel - 1.4571	

baelz 70079

4-SPINDLE BALANCING AND SHUT-OFF VALVE BLOCK for differential pressure sensor baelz 819

Housing: brass

Internal parts: stainless steel

Inlet: Process connection G ¼i incl. cutting ring fitting for Ø 8 mm

Outlet: pipe connection 8 mm

Nominal pressure: PN 40

Temperature / Pressure:

max. 120 °C / 40 bar

Weight approx.: 1.5 kg



baelz 70081

DESCRIPTION

The baelz 70081 is a flanged check valve for industrial applications.

TECHNICAL SPECIFICATIONS

Material: gray cast iron, spheroidal iron or stainless steel

Working fluids for cast iron: water, steam

Working fluids for stainless steel: general industry, food, beverages, aggressive fluids

Metal-to-metal seal

Can be used down to -10 °C

Materials baelz 70081...

	70081A		70081B		70081-VA	
Housing	GJL-250	5.1301	GJS-400-18-LT	5.3103	GX5CrNiMo19-11-2	1.4408
Non-return plug	X20Cr13	1.4021	X20Cr13	1.4021	X5CrNiMo18-10	1.4401
Spring	X12CrNi17-7	1.4310	X12CrNi17-7	1.4310	X5CrNiMo18-10	1.4401
Cover seal	CrNi steel/graphite					

Data and operating parameters

Baelz type	Nominal pressure	Tmax. / Pmax.	Operating pressure	Design	Installation
70081A 70081B	PN 16	PN 16: 300 °C/9.6 bar - 250 °C/11.2 bar -10...+120 °C/16 bar	max. 16 bar	Straight-way type and bonnetless	Horizontal or vertical Without closing spring - installation only upright in horizontal pipe
70081-VA	PN 10 / 16 / 25 / 40	PN 10: 400 °C/6.8 bar - 250 °C/7.9 bar 20 °C/10 bar PN 16: 400 °C/10.9 bar - 250 °C/12.7 bar 20 °C/16 bar PN 25: 400 °C/17.1 bar - 250 °C/19.8 bar 20 °C/25 bar PN 40: 400 °C/27.4 bar - 250 °C/31.8 bar 20 °C/40 bar	max. 10, 16, 25 or 40 bar	Straight-way type, straight seat design	Horizontal or vertical Check valves are installed so that the flow fluid enters under the plug and exits above the plug.

Minimum opening pressures			
Baelz type	DN	with spring (bar)	without spring (bar)
70081A 70081B	15 - 50	0.25	0.025
	65 - 150	0.2	0.016
	200 + 300	0.15	0.022
70081-VA	15 - 50	0.15	-
	65 - 200	0.07	-

Nominal sizes and weights baelz 70081A, 70081B - PN 16														
DN	15	20	25	32	40	50	65	80	100	125	150	200	250	300
Weight approx. (kg)	2.3	3.5	4	6.9	8	10.5	16.8	22	32.5	52	72	123	200	310

Nominal sizes, nominal pressures and weights baelz 70081-VA - PN 10/40, PN 10/16													
DN	15	20	25	32	40	50	65	80	100	125	150	200	
PN	10/40	10/40	10/40	10/40	10/40	10/40	10/16	10/16	10/16	10/16	10/16	10	16
Weight approx. (kg)	5.5	6.6	8.8	11	13.2	17.6	25.3	29.7	45.1	59.4	82.5	132	132

Nominal sizes, nominal pressures and weights baelz 70081-VA - PN 25/40							
DN	65	80	100	125	150	200	
PN	25/40	25/40	25/40	25/40	25/40	25	40
Weight approx. (kg)	32	36	57	81	100	158	164

Kvs value (m³/h) baelz 70081...														
DN →	15	20	25	32	40	50	65	80	100	125	150	200	250	300
70081A 70081B	5.1	7.7	10.5	17.7	31.4	45	87	116	168	270	393	657	1035	1466
70081-VA	11	16	25	36	47	67	103	150	187	285	383	680	-	-



Materials baelz 70082		
Body DN 15 - 100	CuZn39Pb3	2.0401
Body DN 125-200	GJL-250	5.1301
Sealing DN 15-100	Spring-loaded plate	1.4301
Sealing DN 125-200	Plug GJL-250	5.1301

baelz 70082

DESCRIPTION

The baelz 70082 is a clamp-on check valve for industrial applications.

TECHNICAL SPECIFICATIONS

Material: DN 15 - 100: brass

DN 125-200: gray cast iron

Working fluids: liquids, gases, steam, non-aggressive fluids

Metal-to-metal seal

Can be used down to -10 °C

Data and operating parameters baelz 70082

Nominal pressure	Tmax. / Pmax.	Face-to-face length	Installation
PN 6/10/16	250 °C/13 bar - 120 °C/16 bar 50 °C/16 bar	EN 558-1/49 (DIN 3202/3 K4)	Horizontal or vertical Without closing spring - installation only in vertical pipe with flow upwards.

Opening pressures baelz 70082 as a function of flow direction

DN	With spring (mbar)	With spring (mbar)	Without spring (mbar)
	↓	↑	↑
15 - 32	16	24	4
40	15.5	24.5	4.5
50	15	25	5
65	14.5	25.5	5.5
80, 100	13.5	26.5	6.5
125	16	34	14
150	16	33	13
200	16	32	12

Nominal sizes, weights and face-to-face lengths (mm) baelz 70082 - PN 6/10/16

DN	15	20	25	32	40	50	65	80	100	125	150	200
Weight approx. (kg)	0.15	0.25	0.3	0.5	0.65	0.9	1.2	2	2.8	10	13	22
Face-to-face length (mm)	17	20	23	28	31.5	40	46	51	61	90	106	140

Kvs value (m³/h) baelz 70082

DN	15	20	25	32	40	50	65	80	100	125	150	200
Kvs (m³/h)	4	7.5	11	16	28	40	65	91	150	227	307	517



baelz 70084

DESCRIPTION

The baelz 70084 is a wafer-type check valve available in several models.

TECHNICAL SPECIFICATIONS

Material: stainless steel or gray cast iron

Working fluids for stainless steel: liquids, gases, steam

Working fluids for gray cast iron: neutral liquids

Metal-to-metal seal

Materials baelz 70084-E-VA

Housing	GX5CrNiMo19-11	1.4408
Disk	GX5CrNiMo19-11	1.4408
Spring	X10CrNi18-8	1.4310

Materials baelz 70084-R

Body, seat	GJL-250	5.1301
Plug, spigot	GJS-400-15	5.3106
Spring	X6CrNiMoTi17-12-2	1.4571

Materials baelz 70084-LR-VA

Body, seat and guide ribs	GX5CrNiMo19-11	1.4408
Valve disc and spring	X6CrNiMoTi17-12-2	1.4571

Data and operating parameters

Baelz type	Nominal pressure	Tmax. / Pmax.	Face-to-face length	Design	Mounting position
70084-E-VA	PN 6 - 40	max. -30...+240 °C 240 °C/30 bar - 120 °C/40 bar	EN 558-1, series 49	Wafer-type construction with broad sealing surface acc. to DIN 3202, for flanges PN 6...40	Any position, preferably horizontal or vertical
70084-R	PN 16	max. 300 °C/13 bar - 120 °C/16 bar		Fits between flanges PN 6/10/16	Any position, preferably horizontal or vertical. Without spring only for vertical pipes with flow upwards.
70084-LR-VA	PN 10-40	max. 300 °C/31.6 bar - 120 °C/40 bar		Wafer-type construction with broad sealing surface acc. to DIN 3202, for flanges PN 10...40 (also for PN 6)	Any position, preferably horizontal or vertical

Opening pressures (mbar) baelz 70084-E-VA as a function of flow direction			
DN	With spring ↑	With spring →	With spring ↓
15 - 25	25	23	21
32	27	24	21
40, 50	29	25	21
65	31	26	21
80	32	26	21
100	33	27	21

Opening pressures (mbar) baelz 70084-R as a function of flow direction				
DN	Without spring ↑	With spring ↑	With spring →	With spring ↓
125	10.5	31	20.5	10
150	11.5	33	21.5	10
200	11.2	32.4	22.2	10

Opening pressures (mbar) baelz 70084-LR-VA as a function of flow direction				
DN	Without spring ↑	With spring ↑	With spring →	With spring ↓
15	2.5	10	7.5	5
20	2.5	10	7.5	5
25	2.5	10	7.5	5
32	3.5	12	8.5	5
40	4	13	9	5
50	4.5	14	9.5	5
65	5	15	10	5
80	5.5	16	10.5	5
100	6.5	18	11.5	5

baelz 70084-LR-VA with smooth-running special spring
Note: Special springs for specific opening pressures on inquiry

Nominal sizes, weights and face-to-face lengths													
Baelz type	DN →	15	20	25	32	40	50	65	80	100	125	150	200
70084-E-VA	Weight approx. (kg)	0.11	0.14	0.26	0.4	0.6	1	1.3	1.9	3.4	-	-	-
	Face-to-face length (mm)	16	19	22	28	32	40	46	50	60	-	-	-
70084-R	Weight approx. (kg)	-	-	-	-	-	-	-	-	-	6.8	10	20
	Face-to-face length (mm)	-	-	-	-	-	-	-	-	-	90	106	140
70084-LR-VA	Weight approx. (kg)	0.27	0.38	0.52	0.8	1.12	1.78	2.43	3.37	5.34	-	-	-
	Face-to-face length (mm)	16	19	22	28	31.5	40	46	50	60	-	-	-

Kvs value (m³/h) baelz 70084...												
DN →	15	20	25	32	40	50	65	80	100	125	150	200
70084-E-VA	3.5	5.7	8.5	20.5	26.6	37.5	60	82.5	140	-	-	-
70084-R	-	-	-	-	-	-	-	-	-	204	306	525
70084-LR-VA	2.7	5.8	10.3	17.8	27	42	68	88	112	-	-	-



baelz 70098-CL

DESCRIPTION

The baelz 70098-CL is a regulating and isolating valve for use in hot water heating systems. It is suitable for coupling ultrasonic sensors to measure volume flow and temperature.

TECHNICAL SPECIFICATIONS

Body material: gray cast iron

Working fluids: heating water with or without glycol content (max. 60 %). Not suitable for fluids containing mineral oil, steam and fluids which attack EPDM and uncoated cast iron.

Maintenance-free, soft sealing

Materials baelz 70098-CL

Body, seat	GJL-250 - 5.1301
Spindle	Stainless steel (non-rotating)
Spindle sealing	EPDM profile ring
Throttling plug	Gray cast iron with EPDM sheathing as soft-sealing passage and rear seal

Data and operating parameters baelz 70098-CL

Nominal pressure	Tmax. / Pmax.	Face-to-face length	Design	Equipment	Sensors
PN 16	max. -10...+120 °C/ 16 bar	EN 558-1/ ISO 5752/1	Flanged connection, DIN EN 1092-2, flange type 21 straight-way type with slanted seat and bonnetless.	Non-rising hand wheel, locking device, stroke limitation, position indicator in percent, insulating cap with dew point lock. Without sensors.	A measuring computer is required to measure volume flow and temperature (see accessories).

Accessories

ZB700098-CL-201	Sensor set suitable for baelz 70098-CL. Cable length 510 mm. For short-term measurement in connection with measuring computer 70098-MS. Weight approx. 0.2 kg	
70098-MS	Measuring computer for short-term measurement. Mobile device (battery-operated) with USB interface for reading in and reading out data. For temperature and flow display. Delivery includes sensors (in connection with baelz 70098-CL).	
	Body ingress protection rating	IP 54
	Ambient temperature (operation)	5...50 °C
	Measuring range temperature	-10...+120 °C
	Measuring range flow velocity	0.1...4 m/s
	Measuring accuracy flow rate	± 5 % actual value
Weight	approx. 0.3 kg	

baelz 70098-CL

DN	15	20	25	32	40	50	65	80	100	125	150	200
Weight approx. (kg)	2.0	2.4	3.1	5.0	5.8	7.6	11.5	14.5	20.7	31.7	41.6	90.7
Face-to-face length (mm)	130	150	160	180	200	230	290	310	350	400	480	600
Kvs value (m³/h)	11.2	19.6	20.3	31.1	55.7	83	137	176	304	438	558	1008
V max. (m³/h)	2.5	4.4	7.1	12	18	28.7	48.6	74.5	117	179	250	450



baelz 70098/2

DESCRIPTION

The baelz 70098/2 is a balancing and isolating valve for use in heating and cooling systems. It offers highest accuracy for hydraulic systems.

TECHNICAL SPECIFICATIONS

Body material: spheroidal iron

Working fluids: heating water or neutral liquids with or without glycol content (max. 57 %).

Maintenance-free, soft sealing

Materials baelz 70098/2

Housing	GJS-400-15 - 5.3106
Spindle	Stainless steel
Spindle sealing	EPDM ring
Throttling plug	Stainless steel
Hand wheel	Plastic

Data and operating parameters baelz 70098/2

Nominal pressure	Tmax. / Pmax.	Remark	Face-to-face length	Design	Equipment
PN 25	120 °C/25 bar	Higher operating temperatures up to max. 150 °C on inquiry.	ISO 5752/1 DIN 3202/T1F1 EN 558-1/ 1	Flanged connection, straight-way type, slanted seat	With 2 self-sealing measuring nipples Direct digital readout of hand wheel position for precise and easy regulation.

baelz 70098/2

DN	20	25	32	40	50	65	80	100	125
Weight approx. (kg)	2.3	2.9	4.3	5.2	6.6	11	14	19.6	28.1
Face-to-face length (mm)	150	160	180	200	230	290	310	350	400
Kvs value (m³/h)	5.7	8.7	14.2	19.2	33	85	120	190	300



baelz 70171-B-VA

DESCRIPTION

The baelz 70171-B-VA is a stainless steel flanged ball valve for use in heating systems and industrial applications.

TECHNICAL SPECIFICATIONS

Material: stainless steel
 Working fluids: steam
 Silicone-free

Materials baelz 70171-B-VA

Housing	GX5CrNiMo19-11 - 1.4408
Ball	GX5CrNiMo19-11 - 1.4408
Body seal	PTFE + FPM
Ball seal	PTFE / TFM
Spindle seal	PTFE / EPDM
Hand lever	Stainless steel, plastic coated

Data and operating parameters baelz 70171-B-VA

Nominal pressure / Nominal size		Tmax. / Pmax.	Face-to-face length	Design
PN 16 / PN 40	DN 15...50	215 °C/25 bar - 50 °C/40 bar	EN 558-1	Flanged connection EN ISO 5211, Straight-way type
PN 16	DN 65...100	215 °C/30 bar - 50 °C/16 bar		
PN 40	DN 65...100	215 °C/18 bar - 50 °C/40 bar		
PN 16	DN 125	180 °C/12 bar - 50 °C/16 bar		

baelz 70171-B-VA

DN	15	20	25	32	40	50	65	65	80	100	100	125
PN	16/40	16/40	16/40	16/40	16/40	16/40	16	40	16/40	16	40	16
Weight approx. (kg)	2.35	2.95	4.1	5.6	6.65	9.1	13.3	14.3	19.2	25.5	29.6	46.2
Face-to-face length (mm)	115	120	125	130	140	150	170	170	180	190	190	325
Kvs value (m³/h)	16.3	29.5	43	89	230	265	540	540	873	1390	1390	1707

Accessories

Baelz type	Spindle extension for baelz 70171-B-VA, length approx. 100 mm (supplied unassembled)
ZB70171-VL-DN 15 ...and intermediate sizes up to...	
ZB70171-VL-DN 125	



baelz 70195GA



Option: baelz 402

baelz 70195

DESCRIPTION

The baelz 70195 is a soft-sealing, centric butterfly valve for use in water heating systems according to DIN EN 12828, air-conditioning, cooling, water supply, drinking water and service water systems.

TECHNICAL SPECIFICATIONS

Material: spheroidal iron
 Working fluids: steam
 Mounting position: any
 DVGW certified
 Maintenance-free

Option	Description
baelz 402	Larger sized baelz 70195 butterfly valves are available as a pre-assembled unit with the electric motorized rotary actuator baelz 375-E42.

Materials baelz 70195A, baelz 70195GA

Housing	GJS-400-15	5.3106
Shaft	X29CrS13	1.4029
Disk	X4CrNi18-10	1.4301
Ring bellows seal	EPDM	

Operating parameters

Baelz type	Nominal pressure	Temperature	Operating pressure	Differential pressure (at ambient temperature)	Permissible flow velocity
70195A	PN 6/10/16	max. -10...+130 °C	max. 6, 10 or 16 bar	DN 20 - 200: max. 16 bar DN 250 + 300: max. 10 bar	max. 4 m/s with water
70195GA	PN 10/16		max. 10 or 16 bar	max. 16 bar	

baelz 70195

Baelz type	Design	Face-to-face length	Tested
70195A	Semi-lug type body Wafer design	EN 558-1-20 and ISO 5752-20	Body, pressure and safety testing according to EN 12266-1/ Leakage rate A and ISO 5208/Category A
70195GA	Full-lug type body. With raised face - suitable for downstream dismantling and dead-end service. With locking hand lever.		

baelz 70195A

DN	20	25	32	40	50	65	80	100	125	150	200	250	300
Weight approx. (kg)	1	1.1	1.4	1.7	2	2.7	3.3	5.1	6.1	8.8	12.9	20	35.4
Face-to-face length (mm)	27	27	27	33	43	46	46	52	56	56	60	68	78
Kvs value (m³/h)	15	40	55	65	130	275	500	750	1650	2600	4100	6550	8550

baelz 70195GA

DN	20	25	32	40	50	65	80	100	125	150	200/PN 10	200/PN 16
Weight approx. (kg)	1.2	1.2	2.5	2.5	3	3.5	5	6.2	9.7	12	26.2	26.2
Face-to-face length (mm)	27	27	27	33	43	46	46	52	56	56	60	60
Kvs value (m³/h)	15	40	55	65	130	275	500	750	1650	2600	4100	4100



baelz 70200Rg

DESCRIPTION

The baelz 70200Rg is a strainer made of red bronze or brass, depending on the size of the housing, for use in heating systems and industrial applications.

TECHNICAL SPECIFICATIONS

Material: red bronze / brass

Working fluids: neutral liquids, water steam, mineral, heating and hydraulic oils, air and other non-hazardous, non-aggressive gases

With socket connection, internal thread

With replaceable screen available in two mesh sizes

Materials baelz 70200Rg...

Body G ¼ - 2	CuSn5Zn5Pb5-C (Rg5)
Body G 2½ - 3	Brass
Head piece	Brass
Single screen 70200Rg	Stainless steel, mesh size 0.6 mm
Fine screen 70200Rg-FS	Stainless steel, mesh size 0.25 mm

Operating parameters baelz 70200Rg...

Baelz type	Nominal pressure	Tmax. / Pmax.
70200Rg	PN 25	-10...150°C/25 bar
70200Rg-FS	PN 16	300 °C/10 bar - 120 °C/16 bar

Note: For spare parts, see baelz 90200

baelz 70200Rg...

Housing	G ¼	G ¾	G ½	G ¾	G 1	G 1¼	G 1½	G 2	G 2½	G 3
Weight approx. (kg)	0.2	0.2	0.2	0.4	0.6	0.9	1.2	1.9	3.5	5.2
Kvs value (m³/h) 70200Rg - Single screen	1.5	1.7	3.8	7.8	13.4	23.9	32.5	56.2	101.3	133.6
Kvs value (m³/h) 70200Rg-FS - Fine screen	1.4	1.6	3.4	6.9	10.9	20.7	27.4	47.3	82.1	102



baelz 70200-R-GL

DESCRIPTION

The baelz 70200-R-GL is a gray cast iron strainer for use in heating systems and industrial applications.

TECHNICAL SPECIFICATIONS

Material: gray cast iron
 Working fluids: neutral liquids (not suitable for steam)
 Face-to-face length DIN EN 558-1, series 1
 With replaceable screen available in two mesh sizes

Materials baelz 70200-R-GL...

Body / Cover	GJL-250 - 5.1301
Single screen 70200-R-GL, DN 15 + 20	X5CrNi18-10 - 1.4301, mesh size 0.5 mm
Single screen 70200-R-GL, DN 25 - 65	X5CrNi18-10 - 1.4301, mesh size 0.8 mm
Single screen 70200-R-GL, DN 80 - 200	X5CrNi18-10 - 1.4301, mesh size 1.2 mm
Fine screen 70200-R-GL-FS, DN 15 - 200	X5CrNi18-10 - 1.4301, mesh size 0.25 mm

Operating parameters baelz 70200-R-GL...

Nominal pressure	Tmax. / Pmax.
PN 16	300°C/10 bar - 120 °C/16 bar

Note: For spare parts, see baelz 99.70200...

baelz 70200-R-GL...

DN	15	20	25	32	40	50	65	80	100	125	150	200
Weight approx. (kg)	2.2	3.3	3.8	5	6.5	8.5	12	16	25	39	61	109
Kvs value (m³/h) 70200-R-GL - Single screen	5.3	9.5	16.5	20	33	54	95	140	201	340	526	870
Kvs value (m³/h) 70200-R-GL-FS - Fine screen	5	9	14.8	18	30	48	85	131	189	320	494	818



baelz 70200-R-GS

DESCRIPTION

The baelz 70200-R-GS is a spheroidal iron strainer for use in heating systems and industrial applications.

TECHNICAL SPECIFICATIONS

Material: spheroidal iron
 Working fluids: neutral liquids, steam and gases
 Face-to-face length DIN EN 558-1, series 1
 With replaceable screen available in two mesh sizes

Materials baelz 70200-R-GS...

Body / Cover	GJS-400-18-LT - 5.3103	
Single screen 70200-R-GS, DN 15 + 20	X5CrNi18-10 - 1.4301, mesh size 0.5 mm	
Single screen 70200-R-GS, DN 25 - 65	X5CrNi18-10 - 1.4301, mesh size 0.8 mm	
Single screen 70200-R-GS, DN 80 - 200	X5CrNi18-10 - 1.4301, mesh size 1.2 mm	
Single screen 70200-R-GS, DN 250	X5CrNi18-10 - 1.4301, mesh size 1.6 mm	DN 250 each with additional support screen
Single screen 70200-R-GS-FS, DN 15 - 250	X5CrNi18-10 - 1.4301, mesh size 0.25 mm	

Operating parameters baelz 70200-R-GS...

Nominal pressure	Tmax. / Pmax.	
PN 16 / 25	PN 16	300°C/12.8 bar - 120 °C/16 bar
	PN 25	300°C/20 bar - 120 °C/25 bar

Note: For spare parts, see baelz 99.70200...

baelz 70200-R-GS...

DN	15	20	25	32	40	50	65	80	100	125	150	200	250
PN	PN 16/25						PN 16 and PN 25						
Weight approx. (kg)	2.2	3.3	3.8	5	6.5	8.5	12	16.6	25	39	61	109	162
Kvs value (m³/h) 70200-R-GS - Single screen	5.3	9.5	16.5	20	33	54	95	140	201	340	526	870	1260
Kvs value (m³/h) 70200-R-GS-FS - Fine screen	5	9	14.8	18	30	48	85	131	189	320	494	818	1184



baelz 70200-R-GP

DESCRIPTION

The baelz 70200-R-GP is a cast steel strainer for use in heating systems and industrial applications.

TECHNICAL SPECIFICATIONS

Material: cast steel
 Working fluids: neutral liquids, steam and gases
 Face-to-face length DIN EN 558-1, series 1
 With replaceable screen available in two mesh sizes

Materials baelz 70200-R-GP...

Body / Cover	GP240GH - 1.0619	
Single screen 70200-R-GP, DN 15 - 65	X5CrNi18-10 - 1.4301, mesh size 0.8 mm	
Single screen 70200-R-GP, DN 80 - 200	X5CrNi18-10 - 1.4301, mesh size 1.2 mm	
Single screen 70200-R-GP, DN 250	X5CrNi18-10 - 1.4301, mesh size 1.6 mm	DN 250 each with additional support screen
Fine screen 70200-R-GP-FS, DN 15 - 250	X5CrNi18-10 - 1.4301, mesh size 0.25 mm	

Operating parameters baelz 70200-R-GP...

Nominal pressure	Tmax. / Pmax.
PN 40	400°C/23.8 bar - 50 °C/40 bar

Note: For spare parts, see baelz 99.70200...

baelz 70200-R-GP...

DN	15	20	25	32	40	50	65	80	100	125	150	200	250
Weight approx. (kg)	2.5	5	6	8	10	13	19	24	35	51	71	144	178
Kvs value (m³/h) 70200-R-GP - Single screen	7	11	18	26	37	60	100	150	230	330	405	650	1231
Kvs value (m³/h) 70200-R-GP-FS - Fine screen	6.2	10.1	16.8	24.3	32.9	49.5	80.3	115	189	303	400	590	1200



baelz 70200-R-VA

DESCRIPTION

The baelz 70200-R-VA is a stainless steel strainer for use in heating systems and industrial applications.

TECHNICAL SPECIFICATIONS

Material: stainless steel
 Working fluids: neutral liquids, steam and gases
 Face-to-face length DIN EN 558-1, series 1
 With replaceable screen available in two mesh sizes

Materials baelz 70200-R-VA...

Body / Cover	GX5CrNiMo19-11 - 1.4408
Single screen 70200-R-VA, DN 15 - 65	X5CrNiMo17-12-2 - 1.4401, mesh size 0.8 mm
Single screen 70200-R-VA, DN 80 - 150	X5CrNi18-10 - 1.4301, mesh size 1.2 mm
Single screen 70200-R-VA-FS, DN 15 - 150	X5CrNi18-10 - 1.4301, mesh size 0.25 mm

Operating parameters baelz 70200-R-VA...

Nominal pressure	Tmax. / Pmax.	
PN 16 / 40	PN 16	300°C/9 bar - 100 °C/13 bar - 20 °C/16 bar
	PN 25	300°C/21 bar - 120 °C/32 bar - 20 °C/40 bar

Note: For spare parts, see baelz 99.70200...

baelz 70200-R-VA...

DN	15	20	25	32	40	50	65	80	100	125	150
Weight approx. (kg) PN 16	-	-	-	-	-	-	15	21.5	30	41	64
Weight approx. (kg) PN 40	2.8	3.8	5.3	7.2	9	11.8	17.4	24.6	39.7	52.5	70.4
	PN 40						PN 16 and PN 40 - DN 65 - 150 on inquiry				
Kvs value (m³/h) 70200-R-GS - Single screen	7	11	18	26	37	60	100	150	230	330	405
Kvs value (m³/h) 70200-R-GS-FS - Fine screen	6.2	10.1	16.8	24.3	32.9	49.5	80.3	115	189	303	400



baelz 70310-H

DESCRIPTION

The baelz 70310-H is a float steam trap with flanged connection for drainage of steam systems.

TECHNICAL SPECIFICATIONS

Material: gray cast iron or spheroidal iron
 Working fluids: steam, condensate
 With automatic thermal start-up venting
 Integrated strainer screen
 Backflow preventer

Materials baelz 70310-H...

Body / Hood 70310-H-A...	GJL-250 - 5.1301
Body / Hood 70310-H-C...	GJS-400-18U-LT - EN-JS1049
Float	X6CrNiMoTi17-12-2 - 1.4571
Internal parts	Stainless steel
Screen	X5CrNi18-10 - 1.4301

Operating parameters baelz 70310-H...

Baelz type	Nominal pressure	Tmax. / Pmax.	Differential pressure
70310-H-A...	PN 16	300°C/9.6 bar - 120 °C/16 bar	max. 13 bar
70310-H-C...	PN 40	350°C/22 bar - 120 °C/40 bar	max. 32 bar

Weight and length baelz 70310-H...

DN	15	20	25	40	50
face to face (mm)	150	150	160	230	230
Weight approx. (kg)	8.1	8.3	12.1	28.5	29.1

Mounting position and flow direction baelz 70310-H...

Baelz type	Mounting position	Flow direction
70310-H-A-v 70310-H-C-v	Standard mounting position vertical	-
70310-H-A-h-l 70310-H-C-h-l	Special mounting position horizontal	Inflow from left
70310-H-A-h-r 70310-H-C-h-r		Inflow from right

Note: The steam traps are selected according to the flow diagram; on inquiry.
 Subsequent modification of the mounting position on site in accordance with conversion instructions is possible.
 Stainless steel steam trap on inquiry. Observe specifications / restrictions of the regulations!



baelz 70311-H

DESCRIPTION

The baelz 70311-H is a thermal bimetallic steam trap with flanged or threaded socket connection for the discharge of slightly to strongly subcooled condensate. It is equipped with a corrosion-resistant, water hammer-resistant bimetallic regulator for automatically venting during start-up and operation.

TECHNICAL SPECIFICATIONS

Material: heat-resistant constructional steel
 Working fluids: steam, condensate
 Automatic venting
 With external strainer screen
 Backflow preventer

Materials baelz 70311-H...

Housing	P2250GH - 1.0460
Sealing cap	DN 15 - 25: P2250GH - 1.0460
Cover	DN 40 + 50: P2250GH - 1.0460
Internal parts	Stainless steel
Screen	X5CrNi18-10 - 1.4301
Temperature sensor	Corrosion-resistant bimetal

Operating parameters baelz 70311-H...

Nominal pressure	Tmax. / Pmax.	Differential pressure	Inlet pressure
PN 40	385°C/22 bar - 120 °C/40 bar	max. 22 bar	max. 22 bar

Weight and length baelz 70311-H...

	DN	15	20	25	40	50
70311-H-F with flanged connection	face to face (mm)	150	150	160	230	230
	Weight approx. (kg)	3.2	3.7	4.2	11.3	12.1
	DN	½"	¾"	1"	1½"	2"
70311-H-M with threaded socket connection	end-end length (mm)	95	95	95	160	210
	Weight approx. (kg)	1.7	1.7	2.1	8	8



Note: Replacement for DN 25, see baelz 70317-RP.

baelz 70315 / 70316

DESCRIPTION

The baelz 70315 / 70316 is a condensate controller with special sight glass.

TECHNICAL SPECIFICATIONS

Body / Cover: gray cast iron GJL-250 - 5.1301
 Sealing: PTFE
 Mounting position: horizontal
 Nominal pressure: PN 16
 Temperature / Pressure: max. 200 °C/13bar - 120°C/16 bar
 Weight approx.: 2 kg

	baelz 70315		baelz 70316	
Connection	Socket connection		Flanged connection	
DN	1/2"	3/4"	15	20
Weight approx. (kg)	2	2	2	3.7
Kvs value (m³/h)	4.7	4.7	2.8	4.7



baelz 70317

DESCRIPTION

The baelz 70317 are flow sight glasses for visual inspection of filling and flow in pipelines available with or without rotor.

TECHNICAL SPECIFICATIONS

Body material: gray cast iron or heat-resistant cast steel

Mounting position: any; observe flow direction!

Materials baelz 70317...

	baelz 70317	baelz 70317/1	baelz 70317-RP
Housing	GJL-250 - 5.1301	GP240GH - 1.0619	GJL-250 - 5.1301
Cover	S235JRG2 - 1.0038	S235JRG2 - 1.0038	S235JRG2 - 1.0038
Sight glass	Borosilicate glass DIN 7080	Borosilicate glass DIN 7080	Borosilicate glass DIN 7080
Sealing	PTFE	Pure graphite	Pure graphite
Rotor	-	-	PTFE

Operating parameters baelz 70317...

Baelz type	Nominal pressure	Tmax. / Pmax.
70317	PN 16	200°C/12.8 bar - 120 °C/16 bar
70317/1	PN 40	280°C/28 bar - 120 °C/40 bar
70317-RP	PN 16	260°C/11.8 bar - 120 °C/16 bar
70317-RP, DN 50*	PN 40	260°C/40 bar

* Other sizes available upon request

Weight baelz 70317...

DN	15	20	25	32	40	50	65	80
70317 Weight approx. (kg)	3.3	4.1	5.5	8.2	8.5	12.7	22.6	23.5
70317/1 Weight approx. (kg)	4.1	4.2	6.5	8.7	11.5	13.9	22.5	31
70317-RP Weight approx. (kg)	3.8	4.6	6	8.7	9	13.2	23.1	24



Actuation overpressure component tested:
DN 20: from 2.4 bar to 10 bar

DN 25 - 100: from 1.0 bar to 10 bar
 Actuation overpressure below 1 bar on inquiry.

Please specify actuation overpressure when ordering! For certificates or attestations, see supplementary charges

baelz 70341

DESCRIPTION

The baelz 70341 is a high performance diaphragm safety valve for heat generation plants with flow temperatures of 120°C. For plants according to DIN 4751 part 2.

TECHNICAL SPECIFICATIONS

Component-tested, code letters D/G/H

Flanged connection, angle type

With closed protective bonnet and open lift housing

baelz 70341...

Baelz type	Body / Bonnet		Inlet/Outlet	Internal parts	Valve disc	Diaphragm	Nominal pressure	Tmax.
70341A	GJL-250	5.1301	DIN 2533 PN 16	Stainless steel	Can be lifted	EPDM	PN 16	140 °C
70341B	GJS-400-18-LT	5.3103	DIN 2545 PN 40 / DIN 2543 PN 16				PN 40	
70341C	GP240GH	1.0619	DIN 2545 PN 40 / DIN 2543 PN 16				PN 40	

Weights baelz 70317A, 70317B, 70317C

Inlet/Outlet	DN 20/ DN 32	DN 25/ DN 40	DN 32/ DN 50	DN 40/ DN 65	DN 50/ DN 80	DN 65/ DN 100	DN 80/ DN 125	DN 100/ DN 150
Weight approx. (kg)	10	12.5	15	24	26	46	50	72

Extra charges

MP70341-DIN EN 10204-2.2	Factory test certificate DIN EN 10204-2.2 including setting certificate and declaration of conformity. Costs per order item.
MP70341-DIN EN 10204-2.2	Factory test certificate DIN EN 10204-3.1 including setting certificate and declaration of conformity. Costs per order item.
MP70341-TÜV-Einstellbescheinigung-50	TÜV setting certificate and declaration of conformity up to DN 50. Costs per safety valve.
MP70341-TÜV-Einstellbescheinigung-100	TÜV setting certificate and declaration of conformity DN 65...100. Costs per safety valve.



baelz 70500

DESCRIPTION

The baelz 70500 is a 2-way socket valve with hand wheel for use in heating systems and industrial applications.

TECHNICAL SPECIFICATIONS

Material: red bronze or stainless steel

Working fluids for red bronze: non-flammable, non-toxic liquids, steam and gases

Working fluids for stainless steel: water, oils, gases, alkalis, chemical, petrochemical, pharmaceutical and food products

Materials baelz 70500	
Housing	Red bronze CC491K
Bonnet	Screwed in, brass CW612N
Plug seal	PTFE

Materials baelz 70500-VA	
Housing	GX5CrNiMo19-11 - 1.4408
Internal parts	Stainless steel
Spindle	X5CrNiMo17-12-2 - 1.4401
Stuffing box	X5CrNiMo17-12-2 - 1.4401
Seal	PTFE, +15 % glass fiber

Data and operating parameters baelz 70500...				
Baelz type	Nominal pressure	Tmax. / Pmax.	Connection	Standard
70500	PN 16	-10...+80 °C/16 bar -10...+120 °C/10 bar -10...+160 °C/6 bar	Internal thread on both sides	Valve according to DIN 3844
70500-VA	PN 16	Up to G 1½: 140°C/3 bar - 120 °C/5 bar - 30 °C/16 bar G2: 130°C/2.5 bar - 120 °C/3.5 bar - 25 °C/15 bar	Internal thread on both sides	Threaded connections according to DIN 2999

baelz 70500...									
Nominal diameter		G ¼	G ⅜	G ½	G ¾	G 1	G 1¼	G 1½	G 2
70500	Weight approx. (kg)	0.3	0.3	0.3	0.4	0.7	1	1.3	2.1
70500-VA	Weight approx. (kg)	-	-	0.35	0.4	0.6	0.95	2.1	3.4
70500	Kvs value (m³/h)	1.3	1.3	2.5	6.0	9.6	15.6	21.6	35.0
70500-VA	Kvs value (m³/h)	-	-	3.8	7	11	21	29	50

Note: Replacement seals on inquiry.



baelz 70512

DESCRIPTION

The baelz 70512 is a flow measurement and regulating valve with hand wheel for fine adjustment and for use in central heating and cooling systems (not for steam).

TECHNICAL SPECIFICATIONS

Material: red bronze
 Working fluids: water
 DN 15 - 32 DVGW-tested

Materials baelz 70512

Body / Head piece	Red bronze CC491K
Plug / Spindle	Brass (Ms-EZB), resistant to dezincification
Plug seal	PTFE

Data and operating parameters baelz 70512

Baelz type	Nominal pressure	Temperature	Operating pressure max.	Connection
70512	DN 15-50: PN 25 DN 65: PN16	-20...+150 °C	DN 15-50: 25 bar DN 65: 16 bar	Female thread on both sides EN 10226 (internal thread)

baelz 70512

DN	15 G ½	20 G ¾	25 G 1	32 G 1¼	40 G 1½	50 G 2	65 G 2½
Weight approx. (kg)	0.63	0.65	1	1.4	1.8	2.6	3.6
Kvs value (m³/h)	3.88	5.71	8.89	19.45	27.51	38.78	50



baelz 70574

DESCRIPTION

The baelz 70574 is a backflow preventer that can be used as a **valve for protecting drinking water** (EN 12729).

TECHNICAL SPECIFICATIONS

Material: brass alloy or red bronze

Working fluid: water

DVGW certified

Materials baelz 70574

Body and cover	½" to 1¼"	Dezincification-free brass alloy CW602N
	1½" and 2"	Red bronze Rg5Pb3
Retaining rods		Stainless steel
Exhaust valve seat	½" to ¾"	Dezincification-free brass alloy CW602N
	1" to 2"	Stainless steel
Springs		Stainless steel
Diaphragm		EPDM
Seals		In contact with water: NBR
Shut-off valve seat		Brass CW167N, chrome-plated
Strainer body		Red bronze GB491K
Strainer cartridge		Stainless steel

Data and operating parameters baelz 70574

Operating temperature	Operating pressure	Connection	Pressure connections	Filter
max. 65 °C	max. 10 bar	External thread with fittings	¼" F	Mesh size 0.8 mm

Weights baelz 70574

Nominal diameter	½"	¾"	1"	1¼"	1½"	2"
Weight approx. (kg)	2.9	2.9	3.6	3.8	11.3	11.4



baelz 70580-1

DESCRIPTION

The baelz 70580-1 is a heavy duty brass ball valve for use in heating systems and industrial applications.

TECHNICAL SPECIFICATIONS

Material: brass nickel-plated
 Working fluids: water, oils, compressed air, fuels, solvents, steam (G ¼ - 2)
 Bore type: full bore
 Spindle extension optional

Materials baelz 70580-1

Housing	Brass MS58 nickel-plated	
Ball	Brass MS58 chrome-plated	
Ball seal	PTFE	
Sealing	G ¼ - 2	Stuffing box PTFE
	G 2½ - 3	O-ring 1 x Viton, 1 x Perbunan
Hand lever	Galvanized steel with black plastic coating from 2½"	

Data and operating parameters baelz 70580-1

Nominal diameter	Tmax. / Pmax.			Connection
	170°C/15 bar	130 °C/23 bar	30 °C/65 bar	
G ¼ - G ½	170°C/15 bar	130 °C/23 bar	30 °C/65 bar	Internal thread on both sides DIN ISO 228
G ¾ - G2	170°C/10 bar	130 °C/15 bar	30 °C/40 bar	
G 2½	170°C/1 bar	130 °C/10 bar	30 °C/18 bar	
G 3	170°C/1 bar	130 °C/5 bar	30 °C/15 bar	

baelz 70580-1

Nominal diameter	G ¼	G ¾	G ½	G ¾	G 1	G 1¼	G 1½	G 2	G 2½	G 3
Weight approx. (kg)	0.19	0.19	0.26	0.45	0.8	1.1	1.55	2.5	5.25	7.4
Face-to-face length (mm)	51	51	61	74.5	90.5	104	117	135	148	168
Kvs value (m³/h)	5	11	20	45	60	120	170	280	510	770

Accessories baelz 70580-1

Spindle extension, nickel-plated brass (supplied unassembled)

	Height (mm)	Weight approx. (kg)
ZB70580-VL-G 1/4	56.5	0.12
ZB70580-VL-G 3/8		
ZB70580-VL-G 1/2		
ZB70580-VL-G 3/4	62.5	0.17
ZB70580-VL-G 1		
ZB70580-VL-G 1 1/4	64.0	0.30
ZB70580-VL-G 1 1/2		
ZB70580-VL-G 2		

Note: Ball valves in other designs and materials, e.g. for drinking water installations or with temperature indicator available on inquiry.



baelz 70580-B-VA

DESCRIPTION

The baelz 70580-B-VA is a DVGW* certified stainless steel ball valve with a two-piece body for use in heating systems and industrial applications.

TECHNICAL SPECIFICATIONS

Material: Stainless steel 1.4408
 Working fluids: water, oils, compressed air, fuels, solvents, steam, aggressive fluids, foodstuffs, beverages
 Bore type: full bore
 With long T-handle, suitable for insulation

Materials baelz 70580-B-VA

Housing	Stainless steel 1.4408
Ball	Stainless steel 1.4408
Ball seal	PTFE
Housing seal	PTFE
T-handle	Polyamide

Data and operating parameters baelz 70580-B-VA

Nominal diameter	Tmax. / Pmax.		Connection
up to G 1	130°C/25 bar	50 °C/40 bar	Internal thread on both sides DIN ISO 228-1
from G 1¼-2	150°C/16 bar	50 °C/25 bar	

baelz 70580-B-VA

Nominal diameter	G ¼	G ⅜	G ½	G ¾	G 1	G 1¼	G 1½	G 2
Weight approx. (kg)	0.13	0.10	0.21	0.31	0.45	0.74	1.25	1.99
Face-to-face length (mm)	40	40	50	60	68	80	94	106
Total height (mm)	87.5	87.5	90.5	98.5	113.5	123.5	156.5	173

* DVGW: Deutscher Verein des Gas- und Wasserfaches = German Technical and Scientific Association for Gas and Water

Note: Ball valves in other designs and materials, e.g. with temperature indicator available on inquiry.



baelz 70625

DESCRIPTION

The baelz 70625 is a diaphragm safety valve for closed water heaters according to DIN 4753, part 1 and DIN 1988. KTW recommendations for drinking water are observed.

TECHNICAL SPECIFICATIONS

Material: brass
 Working fluid: water
 Spring load not adjustable
 Component-tested, code letter W

Materials baelz 70625...

Body and cover	Brass, angle type
Screw-in part	Up to 6 bar: High-quality plastic
	Over 6 bar: Brass
Spring bonnet	High-quality plastic
Setpoint spring	Spring steel
Diaphragm / Seals	Elastomers, hot water resistant

Data and operating parameters baelz 70625...

Baelz type	Temperature	Actuation overpressure (factory-set)	Mounting position	Connection
70625-6...	max. 95 °C	6 bar	Horizontal, spring bonnet upwards	Inlet/Outlet: Internal thread
70625-8...		8 bar		
70625-10...		10 bar		

baelz 70625...

Baelz type	Max. blow-off capacity (kW)	Weight. approx. (kg)
70625-6-Inlet/Outlet G 1/2 / G3/4	75	0.3
70625-8-Inlet/Outlet G 1/2 / G3/4		
70625-10-Inlet/Outlet G 1/2 / G3/4		
70625-6-Inlet/Outlet G 3/4 / G 1	150	0.4
70625-8-Inlet/Outlet G 3/4 / G 1		
70625-10-Inlet/Outlet G 3/4 / G 1		
70625-6-Inlet/Outlet G 1 / G 1 1/4	250	0.9
70625-8-Inlet/Outlet G 1 / G 1 1/4		
70625-10-Inlet/Outlet G 1 / G 1 1/4		
70625-6-Inlet/Outlet G 1 1/4 / G 1 1/2	2200	1.5
70625-8-Inlet/Outlet G 1 1/4 / G 1 1/2		
70625-10-Inlet/Outlet G 1 1/4 / G 1 1/2		



baelz 70625H

DESCRIPTION

The baelz 70625H is a diaphragm safety valve for closed, thermostatically secured hot water heating systems according to DIN EN 12828 / TRD 721.

TECHNICAL SPECIFICATIONS

Material: brass
 Working fluids: water, neutral, non-adhesive liquids
 Component-tested

Materials baelz 70625H...

Body and cover	Up to G 1¼	Angle type, low-lead brass alloy
	From G 1½	Angle type, low-lead red bronze alloy (resistant to dezincification)
Screw-in part	Up to 6 bar:	High-quality plastic
	Over 6 bar:	Brass
Spring cap		High heat/ageing resistant plastic
Internal parts		High heat/ageing resistant plastic
Diaphragm		High heat/ageing resistant plastic
Spring		Corrosion-protected spring steel wire

Data and operating parameters baelz 70625...

Baelz type	Temperature	Actuation overpressure (factory-set)	Mounting position	Connection
70625H-2.5...	-10...+120 °C	2.5 bar	Any, but bonnet not pointing downwards	Inlet/Outlet: Internal thread
70625H-3...		3 bar		

baelz 70625H...

Baelz type	Max. blow-off capacity (kW)	Weight. approx. (kg)
70625H-2.5-Inlet/Outlet G 1/2 / G3/4	50	0.2
70625H-3-Inlet/Outlet G 1/2 / G3/4		
70625H-2.5-Inlet/Outlet G 3/4 / G 1	100	0.3
70625H-3-Inlet/Outlet G 3/4 / G 1		
70625H-2.5-Inlet/Outlet G 1 / G 1¼	200	0.5
70625H-3-Inlet/Outlet G 1 / G 1¼		
70625H-2.5-Inlet/Outlet G 1¼ / G 1½	350	0.9
70625H-3-Inlet/Outlet G 1¼ / G 1½		
70625H-2.5-Inlet/Outlet G 1½ / G 2	600	2.7
70625H-3-Inlet/Outlet G 1½ / G 2		
70625H-2.5-Inlet/Outlet G 2 / G 2½	900	3.0
70625H-3-Inlet/Outlet G 2 / G 2½		



baelz 70625-H4

DESCRIPTION

The baelz 70625-H4 is a safety valve for closed, thermostatically secured water heating systems with flow temperatures up to 120 °C, according to DIN EN 12828 / TRD 721, for all static heights or nominal outputs above 350 kW as well as solar systems according to DIN 4757, part 1 and 2.

TECHNICAL SPECIFICATIONS

Material: red bronze
 Working fluids: water, liquids, gases, steam
 Component-tested, code letters D/G/H

Materials baelz 70625-H4...

Housing	Red bronze, bronze bellows with metallically supported O-ring EPDM, glycol-resistant
Pressure spring	Stainless steel
Internal parts	Brass

Note: In order to achieve the highest possible heat output, 3 valves may be installed per system.
 Performance table for actuation overpressure >10 bar on inquiry.

Data and operating parameters baelz 70625-H4...

Temperature	Actuation overpressure (factory-set)	Mounting position	Connection
max. 120 °C	0.5...25 bar See performance table	Spring bonnet vertically upwards	Inlet/Outlet: Internal thread

Weights baelz 70625-H4...

Baelz type	Weight. approx. (kg)
70625-H4-Inlet/Outlet G 1/2 / G1	0.4
70625-H4-Inlet/Outlet G 3/4 / G 11/4	1.0
70625-H4-Inlet/Outlet G 1 / G 11/2	1.8
70625-H4-Inlet/Outlet G 11/4 / G 2	4.0

Performance table baelz 70625-H4...

Connection G	1/2	3/4	1	11/4
Actuation overpressure (bar)	Max. blow-off capacity (kW)			
0.5	27	62	96	167
1	37	84	131	227
2	54	123	192	333
3	89	210	320	555
4	109	258	393	682
5	129	305	465	808
6	149	352	537	931
7	168	397	605	1051
8	187	442	674	1170
9	206	487	742	1287
10	225	530	808	1402



baelz 70625-VA

DESCRIPTION

The baelz 70625-VA is a stainless steel safety valve for protection of steam boilers and pressure vessel systems for steam, air and neutral gases.

TECHNICAL SPECIFICATIONS

Material: stainless steel
 Working fluids: water, liquids, gases, steam
 Component-tested, code letters D/G (S/G)
 Plug can be lifted

Materials baelz 70625-VA...

Housing - inlet body	X6CrNiMoTi17-12-2	1.4571
Housing - outlet body	GX5CrNiMo19-11	1.4408
Pressure spring	X10CrNiMoTi17-12-2	1.4571
Internal parts	X6CrNiMoTi17-12-2	1.4571
Sealing	PTFE	

Note: Performance table for actuation overpressure >10 bar on inquiry.

Data and operating parameters baelz 70625-VA...

Temperature	Actuation overpressure (factory-set)	Mounting position	Connection
max. 225 °C	0.5...25 bar See performance table	Spring bonnet vertically upwards	Inlet/Outlet: Internal thread

Weights baelz 70625-VA...

Baelz type	Weight. approx. (kg)
70625-VA-Inlet/Outlet G 1/2 / G1	0.4
70625-VA-Inlet/Outlet G 3/4 / G 11/4	1.0
70625-VA-Inlet/Outlet G 1 / G 11/2	1.8
70625-VA-Inlet/Outlet G 11/4 / G 2	4.0

Performance table baelz 70625-H4...

Connection G	1/2	3/4	1	11/4
Actuation overpressure (bar)	Max. steam blow-off capacity (kg/h)			
0.5	42	80	142	278
1	71	111	197	387
2	106	188	334	655
3	141	251	446	873
4	176	312	555	1088
5	211	374	665	1303
6	246	436	775	1519
7	280	496	883	1730
8	315	558	992	1944
9	349	619	1100	2156
10	384	679	1208	2368

baelz 70700A-l...

Connection spigot

DIN 16282-6 (form 6)

Temperature: max. 400 °C

Connection: G ½ **left**

70700 A-l Material: P250GH 1.0460

70700 A-l-VA Material: XCrNiMoTi17-12-2 1.4571

Weight approx.: 0.1 kg

Note: baelz 70700-A... For welding to pipeline, drilled hole Ø 15 mm required.

baelz 70700A-r...

Connection spigot

DIN 16282-4 (form 4)

Temperature: max. 400 °C

Connection: G ½ **right**

70700 A-r Material: P250GH 1.0460

70700 A-r-VA Material: XCrNiMoTi17-12-2 1.4571

Weight approx.: 0.1 kg

baelz 70700M...

Clamping sleeves

DIN 16283-3 (form 3)

70700 M Material: 11SMnPb30 (9SMnPb28) Temp.: max. 300 °C

70700 M/1 Material: 13CrMo44 1.7335 Temp.: max. 400 °C

70700 M-VA Material: XCrNiMoTi17-12-2 1.4571 Temp.: max. 400 °C

Connection: G ½ right and G ½ left

Weight approx.: 0.1 kg

Note: Suitable sealing discs for baelz 70700M, see baelz 70705



Fig: baelz 70701S-AG

baelz 70701S-AG...

Manometer tube, trumpet shape

70701S-AG	Material:	P235GH	1.0345 seamless
70701S-AG-VA	Material:	X6CrNiMoTi17-12-2	1.4571
70701S-AG	Dimensions:	20 x 2.60 mm	
70701S-AG-VA	Dimensions:	20 x 2.50 mm	
Temp./Pressure:	max. 400 °C/63 bar; 300 °C/80 bar; 120 °C/ 100 bar suitable for steam		
Connection:	bent, DIN 16282, form C		
	Inlet:	connection spigot DIN 16282-4 G ½ right	
	Outlet:	connection spigot DIN 16282-6 G ½ left with clamping sleeve DIN 16283 G ½ right-left	
Weight approx.:	0.1 kg		

baelz 70702S-AG...

Manometer tube, U-shape

70702S-AG	Material:	P235GH	1.0345 seamless
	Dimensions:	20 x 2.60 mm	
70702S-AG-VA	Material:	X6CrNiMoTi17-12-2	1.4571
	Dimensions:	20 x 2.50 mm	
Temp./Pressure:	max. 400 °C/63 bar; 300 °C/80 bar; 120 °C/ 100 bar suitable for steam		
Connection:	bent, DIN 16282, form A		
	Inlet:	connection spigot DIN 16282-4 G ½ right	
	Outlet:	connection spigot DIN 16282-6 G ½ left with clamping sleeve DIN 16283 G ½ right-left	
70702S-AGS	as baelz 70702S-AG and		
70702S-AGS-VA	as baelz 70702S-AG-VA but tube - seen from the pressure tapping side - bent to the right		
Weight approx.:	0.1 kg		



Fig: baelz 70702S-AG-VA

baelz 70703

Comb-profiled seal

for manometers and manometer isolating valves

70703 Material: copper

70703-VA Material: XCrNiMoTi17-12-2 1.4571

Weight G ¼ approx.: 0.09 g (70703-G 1/4 and 70703-VA-G 1/4)

Weight G ½ approx.: 0.25 g (70703-G 1/2 and 70703-VA-G 1/2)



baelz 70705

Sealing discs G½

Suitable for clamping sleeves baelz 70700...

70705-G 1/2 Material: copper

70705-VA-G 1/2 Material: XCrNiMoTi17-12-2 1.4571

baelz 70730

Valve fluid level indicator with spigot connection

Upper and lower shut-off, bottom with drain valve

Material: brass

Connection: G ½, spigot connection

For glass tube: outer Ø/inner Ø 13/10 mm

Supplied without glass tube

Nominal pressure: PN 16

Temperature/Pressure: max. 200 °C/16 bar (see note)

Weight approx.: 0.8 kg

Note: Observe the given operating conditions of the glass tubes.
Glass tubes see baelz 70749

baelz 70749

Duran glass tubes

Alkali resistant

Material: borosilicate glass

Temperature/Pressure: max. 200 °C/16 bar

baelz 70749

Baelz type	Length (mm)	Diameter (mm)	Weight approx. (kg)
70749-13x1.5-1000 mm	1000	13 x 1.5	1
70749-13x1.5-1500 mm	1500	13 x 1.5	1.5

baelz 70798-VA

Stainless steel vent valve

Pressure: max. 25 bar

Temperature: 0...150 °C

Fluids: gases and liquids

External thread: G 1/2

Weight, approx.: 0.1 kg





baelz 70802

Bourdon tube manometer

DIN 16063/16064

Class: 1.6

Wetted parts: copper alloy

Ambient temperature: -25...+60 °C

Fluid temperature: up to + 60 °C (see note)

Connection: G ½A, bottom

Silicone-free model

70802-100-u: Body: steel, painted black with chrome-plated slip ring
Ø100 mm, external thread

Weight approx.: 0.4 kg

Note: A water seal must be provided for higher temperatures, see baelz 85800...
Manometer valves see baelz 70075

baelz 70802	
Baelz type	Display range (bar)
70802-100-u-4	0...4
70802-100-u-6	0...6
70802-100-u-10	0...10
70802-100-u-16	0...16
70802-100-u-25	0...25
70802-100-u-40	0...40

baelz 70804-VA

Glycerine filled Bourdon tube manometer

Class: 1.0

Wetted parts: stainless steel 316L

Lens: glass

Ambient temperature: -20...+60 °C

Fluid temperature: up to + 70 °C (see note)

Connection: G ½A, bottom

70804-VA-100-u: Body: stainless steel 1.4301; connection: stainless steel 316L; with bayonet ring, Ø100 mm, external thread

Weight approx.: 1.2 kg

Note: For higher temperatures, a water seal is necessary, see baelz 85800...
Manometer valves see baelz 70075



baelz 70804-VA	
Baelz type	Display range (bar)
70804-VA-100-u-4	0...4
70804-VA-100-u-6	0...6
70804-VA-100-u-10	0...10
70804-VA-100-u-16	0...16
70804-VA-100-u-25	0...25
70804-VA-100-u-40	0...40



baelz 70806-VA

Bourdon tube manometer

Class:	1.0
Ingress protection rating:	IP 54
Wetted parts:	X6CrNiMoTi17-12-2 1.4571
Ambient temperature:	-25...+60 °C
Fluid temperature:	up to + 180 °C (see note)
Connection:	G ½A, bottom
Media:	gaseous, liquid, aggressive, not highly viscous and not crystallizing fluids, also in aggressive environment
70806-VA-100-u:	Body: stainless steel, (bayonet ring case) Sight glass: instrument glass Ø100 mm, external thread
Weight approx.:	0.4 kg

baelz 70806-VA	
Baelz type	Display range (bar)
70806-VA-100-u-6	0...6
70806-VA-100-u-10	0...10
70806-VA-100-u-16	0...16
70806-VA-100-u-25	0...25
70806-VA-100-u-40	0...40

Note: A water seal must be provided for higher temperatures, see baelz 85800... If a water seal is not possible, e.g. for space reasons, please ask for our special designs.
Manometer valves see baelz 70075

baelz 71150-TM-VA

Bimetallic dial thermometer

Display accuracy:	class 1
Body / Ring:	stainless steel
Stem:	stainless steel
Sight glass:	flat instrument glass
Body Ø:	100 mm
Measuring element:	bimetal coil
Ingress protection rating:	IP 43
Stem length:	63, 100 or 160 mm including stainless steel protection tube G½, 1.4571
Connection:	rear
Operating pressure:	max. 25 bar
Weight approx.:	0.4 kg



Type designations baelz 701150-TM-VA

Measuring range	Stem length 63 mm	Stem length 100 mm	Stem length 160 mm
-30...+50 °C	71150-TM-VA-50-63	71150-TM-VA-50-100	71150-TM-VA-50-160
0...120 °C	71150-TM-VA-120-63	71150-TM-VA-120-100	71150-TM-VA-120-160
0...200 °C	71150-TM-VA-200-63	71150-TM-VA-200-100	71150-TM-VA-200-160
0...250 °C	71150-TM-VA-250-63	71150-TM-VA-250-100	71150-TM-VA-250-160
0...300 °C	71150-TM-VA-300-63	71150-TM-VA-300-100	71150-TM-VA-300-160
0...400 °C	71150-TM-VA-400-63	71150-TM-VA-400-100	71150-TM-VA-400-160



baelz 80000

Blind flange

DIN EN 1092-1, type 05, raised face B1

Material: P250GH - 1.0460 stamped

Nominal pressure: PN 16 / 25 / 40

Operating parameters baelz 80000...

Baelz type	Nominal pressure	Tmax. / Pmax.
80000/2-DN..-PN16	PN 16	400°C/9.5 bar - 300 °C/11 bar - 50 °C/16 bar
80000/3-DN..-PN25	PN 25	400°C/14.8 bar - 300 °C/17.2 bar - 50 °C/25 bar
80000/4-DN..-PN40	PN 40	400°C/23.8 bar - 300 °C/27.6 bar - 50 °C/40 bar

baelz 80000...

DN	15	20	25	32	40	50	65	80	100	125	150	200	250	300
Weight PN 16 approx. (kg)	DN 15...50 and DN 80 see 80000/4						3.7	-	5.8	8.6	10.6	16.5	25.6	36.1
Weight PN 25 approx. (kg)	-	-	-	-	-	-	-	-	-	-	-	22.7	-	-
Weight PN 40 approx. (kg)	0.9	1.3	1.4	2.1	2.4	3.2	4.4	6	7.7	11	14.7	27.6	-	-



baelz 80300

Welding neck flange

DIN EN 1092-1, type 11, raised face B1

Material: P250GH - 1.0460 stamped

Nominal pressure: **PN 16 / 25 / 40**

Operating parameters baelz 80300...

Baelz type	Nominal pressure	Tmax. / Pmax.
80300/2-DN..-PN16	PN 16	400°C/9.5 bar - 300 °C/11 bar - 50 °C/16 bar
80300/3-DN..-PN25	PN 25	400°C/14.8 bar - 300 °C/17.2 bar - 50 °C/25 bar
80300/4-DN..-PN40	PN 40	400°C/23.8 bar - 300 °C/27.6 bar - 50 °C/40 bar

Example of type designation:

80300/2-DN125/139.7 mmØ-PN16

baelz 80300/2...

DN/Ø (mm)		65/ 76.1	100/ 114.3	125/ 139.7	150/ 168.3	200/ 219.1	250/ 273	300/ 323.9	350/ 355.6	400/ 406.4
Weight PN 16 approx. (kg)	DN 15...50 and DN 80 see 80300/4	3.1	4.7	6.3	7.8	11	15.6	22	31.2	39.2

baelz 80300/3... and 80300/4...

DN/Ø (mm)	15/ 21.3	20/ 26.9	25/ 33.7	32/ 42.4	40/ 48.3	50/ 60.3	65/ 76.1	80/ 88.9	100/ 114.3	125/ 139.7	150/ 168.3	200/ 219.1	250/ 273	300/ 323.9
Weight PN 25 approx. (kg)	-	-	-	-	-	-	-	-	-	-	-	17	24.4	31.2
Weight PN 40 approx. (kg)	0.8	1.1	1.3	1.9	2.4	2.9	3.8	4.8	6.6	9.1	11.8	21.5	34.9	49.7

Note: PN 63 / 100 on inquiry.



baelz 80600

Welding neck flange set

Consisting of:

2 welding neck flanges baelz 80300... DIN EN 1092-1, type 11, raised face B1
Material: P250GH - 1.0460

2 graphite seals HotFit baelz 80900

Hexagon bolts with nuts in stainless steel A2-70

Operating parameters baelz 80600...

Baelz type	Nominal pressure	Tmax. / Pmax.
80600/2-DN..-PN16	PN 16	400°C/9.5 bar - 300 °C/11 bar - 50 °C/16 bar
80600/3-DN..-PN25	PN 25	400°C/14.8 bar - 300 °C/17.2 bar - 50 °C/25 bar
80600/4-DN..-PN40	PN 40	400°C/23.8 bar - 300 °C/27.6 bar - 50 °C/40 bar

Example of type designation:

80600/2-DN125/139.7 mmØ-PN16

Weight per set baelz 80600/2...

DN/Ø (mm)		65/ 76.1	100/ 114.3	125/ 139.7	150/ 168.3	200/ 219.1	250/ 273	300/ 323.9
Weight PN 16 approx. (kg)	DN 15...50 and DN 80 see 80600/4	7.4	11.9	15.3	20.2	28.8	42.4	55.6

Weight per set baelz 80600/3... and 80600/4...

DN/Ø (mm)	15/ 21.3	20/ 26.9	25/ 33.7	32/ 42.4	40/ 48.3	50/ 60.3	65/ 76.1	80/ 88.9	100/ 114.3	125/ 139.7	150/ 168.3	200/ 219.1	250/ 273	300/ 323.9
Weight PN 25 approx. (kg)	-	-	-	-	-	-	-	-	-	-	-	40.8	60	74
Weight PN 40 approx. (kg)	2.2	2.9	3.3	5	6	7.1	10.3	12.4	17.7	25.6	31.3	61	95.7	137.5



baelz 80700

Welding neck flange set

Consisting of:

3 welding neck flanges baelz 80300... DIN EN 1092-1, type 11, raised face B1
Material: P250GH - 1.0460

3 graphite seals HotFit baelz 80900

Hexagon bolts with nuts in stainless steel A2-70

Operating parameters baelz 80700...

Baelz type	Nominal pressure	Tmax. / Pmax.
80700/2-DN..-PN16	PN 16	400°C/9.5 bar - 300 °C/11 bar - 50 °C/16 bar
80700/3-DN..-PN25	PN 25	400°C/14.8 bar - 300 °C/17.2 bar - 50 °C/25 bar
80700/4-DN..-PN40	PN 40	400°C/23.8 bar - 300 °C/27.6 bar - 50 °C/40 bar

Example of type designation:

80700/2-DN125/139.7 mmØ-PN16

Weight per set baelz 80700/2...

DN/Ø (mm)		65/ 76.1	100/ 114.3	125/ 139.7	150/ 168.3	200/ 219.1	250/ 273	300/ 323.9
Weight PN 16 approx. (kg)	DN 15...50 and DN 80 see 80600/4	11.1	17.9	22.9	30.2	43.2	63.6	83.4

Weight per set baelz 80700/3... and 80700/4...

DN/Ø (mm)	15/ 21.3	20/ 26.9	25/ 33.7	32/ 42.4	40/ 48.3	50/ 60.3	65/ 76.1	80/ 88.9	100/ 114.3	125/ 139.7	150/ 168.3	200/ 219.1	250/ 273	300/ 323.9
Weight PN 25 approx. (kg)	-	-	-	-	-	-	-	-	-	-	-	61.2	89.9	111
Weight PN 40 approx. (kg)	3.3	4.3	4.9	7.5	9	10.6	15.4	18.6	26.6	38.4	47	91.5	143.5	206.2



baelz 80900

Graphite seal HotFit

Material: graphite with expanded metal insert of stainless steel X2CrNiMo17-12-2 - 1.4404 (dimensions DIN EN 1514-1)

Fluid: steam, water, hot oil

Temp./Pressure: max. 350 °C/50 bar for water and water steam
-50 °C/50 bar - 350 °C/50 bar for oils and refrigerant

Applications above 50 bar are possible - on inquiry

baelz 80900...		
Baelz type	Dimensions (mm)	Weight approx. (kg)
80900-DN 15-PN6	44 x 22 x 2	0.005
80900-DN 20-PN6	54 x 27 x 2	0.01
80900-DN 25-PN6	64 x 34 x 2	0.01
80900-DN 32-PN6	76 x 43 x 2	0.01
80900-DN 40-PN6	86 x 49 x 2	0.02
80900-DN 50-PN6	96 x 61 x 2	0.02
80900-DN 65-PN6	116 x 77 x 2	0.03
80900-DN 80-PN6	132 x 89 x 2	0.03
80900-DN 100-PN6	152 x 115 x 2	0.03
80900-DN 125-PN6	182 x 141 x 2	0.05
80900-DN 10-PN10/16/25/40	46 x 18 x 2	0.005
80900-DN 15-PN10/16/25/40	51 x 22 x 2	0.005
80900-DN 20-PN10/16/25/40	61 x 27 x 2	0.01
80900-DN 25-PN10/16/25/40	71 x 34 x 2	0.01
80900-DN 32-PN10/16/25/40	82 x 43 x 2	0.01
80900-DN 40-PN10/16/25/40	92 x 49 x 2	0.02
80900-DN 50-PN10/16/25/40	107 x 61 x 2	0.02
80900-DN 65-PN10/16/25/40	127 x 77 x 2	0.03
80900-DN 80-PN10/16/25/40	142 x 89 x 2	0.03
80900-DN100-PN10/16	162 x 115 x 2	0.03
80900-DN125-PN10/16	192 x 141 x 2	0.05
80900-DN150-PN10/16	218 x 169 x 2	0.05
80900-DN200-PN10/16	273 x 220 x 2	0.07
80900-DN250-PN10	328 x 273 x 2	0.07
80900-DN300-PN10	378 x 324 x 2	0.07
80900-DN250-PN16	329 x 273 x 2	0.1
80900-DN300-PN16	384 x 324 x 2	0.1
80900-DN100-PN25/40	168 x 115 x 2	0.03
80900-DN125-PN25/40	194 x 141 x 2	0.05
80900-DN150-PN25/40	224 x 169 x 2	0.05
80900-DN200-PN25	284 x 220 x 2	0.07
80900-DN250-PN25	340 x 273 x 2	0.1
80900-DN300-PN25	400 x 324 x 2	0.1
80900-DN200-PN40	290 x 220 x 2	0.07
80900-DN250-PN40	352 x 273 x 2	0.1
80900-DN300-PN40	417 x 324 x 2	0.15



Example of type designation:
81100-M12 x 45 mm

baelz 81100

Hexagon bolts with nuts, galvanized

Hexagon bolts: DIN EN 24014/24017; grade 5.6

Hexagon nuts: DIN EN 24032; grade 5.2

Temp./Pressure: max. 300 °C/40 bar

Stainless steel screws are required for more demanding operating conditions, see baelz 81101

Metric screw sizes and weights - selection table baelz 81100

DN	PN 6	PN 10	PN 10/16	PN 16	PN 25	PN 25/40	PN 40
10	M10x35 0.05 kg		M12x45 0.07 kg			M12x50 0.08 kg	
15	M10x35 0.05 kg		M12x45 0.07 kg			M12x50 0.08 kg	
20	M10x40 0.05 kg M10x80 0.07 kg		M12x50 0.08 kg			M12x55 0.08 kg M12x90 0.1 kg	
25	M10x40 0.05 kg M10x80 0.07 kg		M12x50 0.08 kg			M12x55 0.08 kg M12x90 0.1 kg	
32	M12x45 0.07 kg		M16x55 0.14 kg			M16x55 0.14 kg	
40	M12x45 0.07 kg		M16x55 0.14 kg			M16x55 0.14 kg	
50	M12x45 0.07 kg		M16x55 0.14 kg			M16x60 0.15 kg	
65	M12x45 0.07 kg		M16x55 0.14 kg			M16x65 0.16 kg	
80	M16x50 0.14 kg		M16x60 0.15 kg			M16x70 0.17 kg M16x80 0.19 kg M16x90 0.2 kg M16x100 0.22 kg M16x110 0.23 kg M16x130 0.26 kg M16x160 0.31 kg	
100	M16x50 0.14 kg		M16x60 0.15 kg			M20x70 0.28 kg	
125	M16x55 0.14 kg		M16x65 0.16 kg			M24x75 0.46 kg	
150	M16x55 0.14 kg	M20x65 0.24 kg		M20x70 0.28 kg	M24x80 0.47 kg	M24x85 0.51 kg	M24x80 0.47 kg
175	M16x60 0.15 kg		M20x70 0.28 kg		M24x80 0.47 kg		M27x90 0.7 kg
200	M16x60 0.15 kg		M20x70 0.28 kg		M24x90 0.65 kg		M27x100 0.74 kg
250	M16x65 0.16 kg	M20x75 0.29 kg		M24x75 0.46 kg	M27x90 0.7 kg		M30x110 1.07 kg
300	M20x65 0.24 kg	M20x80 0.3 kg M20x120 0.4 kg		M24x80 0.47 kg	M27x120 0.83 kg		M30x120 1.18 kg
350	M20x65 0.24 kg	M20x160 0.5 kg		M24x90 0.65 kg	M30x110 1.07 kg		M33x130 1.55 kg
400	M20x65 0.24 kg	M24x75 0.46 kg		M27x90 0.7 kg	M33x110 1.35 kg M33x120 1.48 kg		M36x140 1.84 kg
500	M20x70 0.28 kg	M24x80 0.47 kg					



Example of type designation:
81101-M16 x 65 mm

baelz 81101

Stainless steel hexagon bolts with nuts

Material: A2-70

Temperature: max. 400 °C

Pressure: max. PN 100

Metric screw sizes and weights - selection table baelz 81101

DN	PN 6	PN 10	PN 10/16	PN 16	PN 25	PN 25/40	PN 40
10						M12x50 0.08 kg	
15						M12x50 0.08 kg	
20			M12x50 0.08 kg			M12x55 0.08 kg	
25			M12x50 0.08 kg			M12x55 0.08 kg	
32							M16x55 0.14 kg
40							M16x55 0.14 kg
50						M16x60 0.15 kg	
65						M16x65 0.16 kg	
80			M16x60 0.15 kg			M16x70 0.17 kg	
100			M16x60 0.15 kg			M20x75 0.29 kg	
125			M16x65 0.16 kg			M24x75 0.46 kg	
150				M20x70 0.28 kg	M24x80 0.47 kg	M24x85 0.51 kg	M24x80 0.47 kg
175	M16x60 0.15 kg		M20x70 0.28 kg		M24x80 0.47 kg		M27x90 0.7 kg
200	M16x60 0.15 kg		M20x70 0.28 kg	M20x75 0.29 kg	M24x90 0.65 kg		M27x100 0.74 kg
250	M16x65 0.16 kg			M24x75 0.46 kg	M27x90 0.7 kg		M30x110 1.07 kg
300				M24x80 0.47 kg			M30x120 1.18 kg
350				M24x90 0.65 kg	M30x110 1.07 kg		
400		M24x75 0.46 kg		M27x90 0.7 kg			
500	M20x70 0.28 kg	M24x80 0.47 kg					



baelz 81200 / 81300

Steel pipe elbow

baelz 81200: form 2, 90°, DIN EN 10253

baelz 81300: form 3, 90°, DIN EN 10253

Material: P235GH - 1.0345

Design: seamless steel tube EN 10216-2
with smooth ends EN 9692 1
from 3 mm wall thickness with bevel EN 9692 1.3

Weights baelz 81200

Baelz type	Weight (kg)
81200-21.3 x 2.0 mmØ	0.03
81200-26.9 x 2.3 mmØ	0.06
81200-33.7 x 2.6 mmØ	0.08
81200-42.4 x 2.6 mmØ	0.2
81200-48.3 x 2.6 mmØ	0.2
81200-57.0 x 2.9 mmØ	0.4
81200-60.3 x 2.9 mmØ	0.4
81200-76.1 x 2.9 mmØ	0.6
81200-88.9 x 3.2 mmØ	0.9
81200-108.0 x 3.6 mmØ	1.5
81200-114.3 x 3.6 mmØ	1.6
81200-139.7 x 4.0 mmØ	2.7
81200-159.0 x 4.5 mmØ	4.1
81200-168.3 x 4.5 mmØ	4.4
81200-219.1 x 6.3 mmØ	10.5

Weights baelz 81300

Baelz type	Weight (kg)
81300-21.3 x 2.0 mmØ	0.04
81300-26.9 x 2.3 mmØ	0.06
81300-33.7 x 2.6 mmØ	0.2
81300-42.4 x 2.6 mmØ	0.2
81300-48.3 x 2.6 mmØ	0.3
81300-60.3 x 2.9 mmØ	0.5
81300-76.1 x 2.9 mmØ	0.8
81300-88.9 x 3.2 mmØ	1.3
81300-114.3 x 3.6 mmØ	2.4
81300-139.7 x 4.0 mmØ	4.1
81300-168.3 x 4.5 mmØ	6.6
81300-219.1 x 6.3 mmØ	15.8
81300-273.0 x 6.3 mmØ	24.8
81300-323.9 x 7.1 mmØ	36.9
81300-406.4 x 8.8 mmØ	82.6

Note: Please also order acceptance test certificates according to EN 1024/3.1 (subject to charge), if necessary.



baelz 81500

Tee fittings

DIN EN 10253-2 type A / DIN 2615 part 1

Material: P235GH - 1.0345

Design: seamless steel tube EN 10216-2

Weights baelz 81500

Baelz type	Weight (kg)
81500-21.3 x 2.0 mmØ	0.08
81500-26.9 x 2.3 mmØ	0.12
81500-33.7 x 2.6 mmØ	0.26
81500-42.4 x 2.6mmØ	0.45
81500-48.3 x 2.6 mmØ	0.58
81500-60.3 x 2.9 mmØ	0.85
81500-76.1 x 2.9 mmØ	1.2
81500-88.9 x 3.2 mmØ	1.8
81500-108.0 x 3.6 mmØ	2.9
81500-114.3 x 3.6 mmØ	3.1
81500-133.0 x 4.0 mmØ	4.8
81500-139.7 x 4.0 mmØ	5.1
81500-159.0 x 4.5 mmØ	8.1
81500-168.3 x 4.5 mmØ	9.0
81500-219.1 x 6.3 mmØ	18.0
81500-273.0 x 6.3 mmØ	26.5
81500-323.9 x 7.1 mmØ	42.0
81500-355.6 x 10.0 mmØ	76.0
81500-406.4 x 12.5 mmØ	118.0



baelz 81600

Concentric reducers

DIN EN 10253-3 type B

Material: P235GH - 1.0345

Design: seamless steel tube EN 10216-2
with smooth ends EN 9692 1
from 3 mm wall thickness with bevel EN 9692 1.3

Weights baelz 81600

Baelz type	Weight (kg)
81600-26.9 x 2.3 x 21.3 x 2.0 mmØ	0.05
81600-26.9 x 2.3 x 17.2 x 1.8 mmØ	0.05
81600-33.7 x 2.6 x 26.9 x 2.3 mmØ	0.1
81600-33.7 x 2.6 x 21.3 x 2.0 mmØ	0.1
81600-42.4 x 2.6 x 33.7 x 2.6 mmØ	0.12
81600-42.4 x 2.6 x 26.9 x 2.3 mmØ	0.12
81600-42.4 x 2.6 x 21.3 x 2.0 mmØ	0.12
81600-48.3 x 2.6 x 42.4 x 2.6 mmØ	0.18
81600-48.3 x 2.6 x 38.0 x 2.6 mmØ	0.18
81600-48.3 x 2.6 x 33.7 x 2.6 mmØ	0.18
81600-48.3 x 2.6 x 26.9 x 2.3 mmØ	0.18
81600-48.3 x 2.6 x 21.3 x 2.0 mmØ	0.18
81600-60.3 x 2.9 x 48.3 x 2.6 mmØ	0.3
81600-60.3 x 2.9 x 44.5 x 2.6 mmØ	0.3
81600-60.3 x 2.9 x 42.4 x 2.6 mmØ	0.3
81600-60.3 x 2.9 x 38.0 x 2.6 mmØ	0.3
81600-60.3 x 2.9 x 33.7 x 2.6 mmØ	0.3
81600-60.3 x 2.9 x 26.9 x 2.3 mmØ	0.3
81600-60.3 x 2.9 x 21.3 x 2.0 mmØ	0.3
81600-76.1 x 2.9 x 60.3 x 2.9 mmØ	0.47
81600-76.1 x 2.9 x 57.0 x 2.9 mmØ	0.47
81600-76.1 x 2.9 x 48.3 x 2.6 mmØ	0.47
81600-76.1 x 2.9 x 44.5 x 2.6 mmØ	0.47
81600-76.1 x 2.9 x 42.4 x 2.6 mmØ	0.47
81600-76.1 x 2.9 x 38.0 x 2.6 mmØ	0.47
81600-76.1 x 2.9 x 33.7 x 2.6 mmØ	0.47
81600-88.9 x 3.2 x 76.1 x 2.9 mmØ	0.56
81600-88.9 x 3.2 x 70.0 x 2.9 mmØ	0.56
81600-88.9 x 3.2 x 60.3 x 2.9 mmØ	0.56
81600-88.9 x 3.2 x 57.0 x 2.9 mmØ	0.56
81600-88.9 x 3.2 x 48.3 x 2.6 mmØ	0.56
81600-88.9 x 3.2 x 44.5 x 2.6 mmØ	0.56
81600-88.9 x 3.2 x 42.4 x 2.6 mmØ	0.56
81600-88.9 x 3.2 x 38.0 x 2.6 mmØ	0.56
81600-88.9 x 3.2 x 33.7 x 2.6 mmØ	0.56
81600-114.3 x 3.6 x 88.9 x 3.2 mmØ	0.9
81600-114.3 x 3.6 x 76.1 x 2.9 mmØ	0.9

Weights baelz 81600

Baelz type	Weight (kg)
81600-114.3 x 3.6 x 60.3 x 2.9 mmØ	0.9
81600-114.3 x 3.6 x 57.0 x 2.9 mmØ	0.9
81600-114.3 x 3.6 x 48.3 x 2.6 mmØ	0.9
81600-114.3 x 3.6 x 44.5 x 2.6 mmØ	0.9
81600-114.3 x 3.6 x 42.4 x 2.6 mmØ	0.9
81600-139.7 x 4.0 x 114.3 x 3.6 mmØ	1.7
81600-139.7 x 4.0 x 108.0 x 3.6 mmØ	1.7
81600-139.7 x 4.0 x 88.9 x 3.2 mmØ	1.7
81600-139.7 x 4.0 x 76.1 x 2.9 mmØ	1.7
81600-139.7 x 4.0 x 60.3 x 2.9 mmØ	1.7
81600-168.3 x 4.5 x 139.7 x 4.0 mmØ	2.5
81600-168.3 x 4.5 x 133.0 x 4.0 mmØ	2.5
81600-168.3 x 4.5 x 114.3 x 3.6 mmØ	2.5
81600-168.3 x 4.5 x 108.0 x 3.6 mmØ	2.5
81600-168.3 x 4.5 x 88.9 x 3.2 mmØ	2.5
81600-168.3 x 4.5 x 76.1 x 2.9 mmØ	2.5
81600-168.3 x 4.5 x 60.3 x 2.9 mmØ	2.5
81600-219.1 x 6.3 x 168.3 x 4.5 mmØ	5.0
81600-219.1 x 6.3 x 159.0 x 4.5 mmØ	5.0
81600-219.1 x 6.3 x 139.7 x 4.0 mmØ	5.0
81600-219.1 x 6.3 x 133.0 x 4.0 mmØ	5.0
81600-219.1 x 6.3 x 114.3 x 3.6 mmØ	5.0
81600-219.1 x 6.3 x 108.0 x 3.6 mmØ	5.0
81600-219.1 x 6.3 x 88.9 x 3.2 mmØ	5.0
81600-273.0 x 6.3 x 219.1 x 6.3 mmØ	7.5
81600-273.0 x 6.3 x 168.3 x 4.5 mmØ	7.5
81600-273.0 x 6.3 x 159.0 x 4.5 mmØ	7.5
81600-273.0 x 6.3 x 139.7 x 4.0 mmØ	7.5
81600-273.0 x 6.3 x 133.0 x 4.0 mmØ	7.5
81600-273.0 x 6.3 x 114.3 x 3.6 mmØ	7.5
81600-323.9 x 7.1 x 273.0 x 6.3 mmØ	11.0
81600-323.9 x 7.1 x 267.0 x 6.3 mmØ	11.0
81600-323.9 x 7.1 x 219.1 x 6.3 mmØ	11.0
81600-323.9 x 7.1 x 168.3 x 4.5 mmØ	11.0
81600-323.9 x 7.1 x 159.0 x 4.5 mmØ	11.0
81600-323.9 x 7.1 x 139.7 x 4.0 mmØ	11.0
81600-323.9 x 7.1 x 133.0 x 4.0 mmØ	11.0



baelz 81600/1

Excentric reducers

DIN EN 10253-2 type B

Material: P235GH - 1.0345

Design: seamless steel tube EN 10216-2
with smooth ends EN 9692 1
from 3 mm wall thickness with bevel EN 9692 1.3

Weights baelz 81600

Baelz type	Weight (kg)
81600/1-26.9 x 2.3 x 21.3 x 2.0 mmØ	0.05
81600/1-33.7 x 2.6 x 26.9 x 2.3 mmØ	0.1
81600/1-33.7 x 2.6 x 21.3 x 2.0 mmØ	0.1
81600/1-33.7 x 2.6 x 17.2 x 1.8 mmØ	0.1
81600/1-42.4 x 2.6 x 33.7 x 2.6 mmØ	0.12
81600/1-42.4 x 2.6 x 26.9 x 2.3 mmØ	0.12
81600/1-42.4 x 2.6 x 21.3 x 2.0 mmØ	0.12
81600/1-48.3 x 2.6 x 42.4 x 2.6 mmØ	0.18
81600/1-48.3 x 2.6 x 38.0 x 2.6 mmØ	0.18
81600/1-48.3 x 2.6 x 33.7 x 2.6 mmØ	0.18
81600/1-48.3 x 2.6 x 26.9 x 2.3 mmØ	0.18
81600/1-48.3 x 2.6 x 21.3 x 2.0 mmØ	0.18
81600/1-60.3 x 2.9 x 48.3 x 2.6 mmØ	0.3
81600/1-60.3 x 2.9 x 44.5 x 2.6 mmØ	0.3
81600/1-60.3 x 2.9 x 42.4 x 2.6 mmØ	0.3
81600/1-60.3 x 2.9 x 38.0 x 2.6 mmØ	0.3
81600/1-60.3 x 2.9 x 33.7 x 2.6 mmØ	0.3
81600/1-60.3 x 2.9 x 26.9 x 2.3 mmØ	0.3
81600/1-60.3 x 2.9 x 21.3 x 2.0 mmØ	0.3
81600/1-76.1 x 2.9 x 60.3 x 2.9 mmØ	0.47
81600/1-76.1 x 2.9 x 57.0 x 2.9 mmØ	0.47
81600/1-76.1 x 2.9 x 48.3 x 2.6 mmØ	0.47
81600/1-76.1 x 2.9 x 44.5 x 2.6 mmØ	0.47
81600/1-76.1 x 2.9 x 42.4 x 2.6 mmØ	0.47
81600/1-76.1 x 2.9 x 33.7 x 2.6 mmØ	0.47
81600/1-88.9 x 3.2 x 76.1 x 2.9 mmØ	0.56
81600/1-88.9 x 3.2 x 70.0 x 2.9 mmØ	0.56
81600/1-88.9 x 3.2 x 60.3 x 2.9 mmØ	0.56
81600/1-88.9 x 3.2 x 57.0 x 2.9 mmØ	0.56
81600/1-88.9 x 3.2 x 48.3 x 2.6 mmØ	0.56
81600/1-88.9 x 3.2 x 44.5 x 2.6 mmØ	0.56
81600/1-88.9 x 3.2 x 42.4 x 2.6 mmØ	0.56
81600/1-88.9 x 3.2 x 33.7 x 2.6 mmØ	0.56
81600/1-114.3 x 3.6 x 88.9 x 3.2 mmØ	0.9
81600/1-114.3 x 3.6 x 76.1 x 2.9 mmØ	0.9

Weights baelz 81600/1

Baelz type	Weight (kg)
81600/1-114.3 x 3.6 x 60.3 x 2.9 mmØ	0.9
81600/1-114.3 x 3.6 x 57.0 x 2.9 mmØ	0.9
81600/1-114.3 x 3.6 x 48.3 x 2.6 mmØ	0.9
81600/1-114.3 x 3.6 x 42.4 x 2.6 mmØ	0.9
81600/1-139.7 x 4.0 x 114.3 x 3.6 mmØ	1.7
81600/1-139.7 x 4.0 x 108.0 x 3.6 mmØ	1.7
81600/1-139.7 x 4.0 x 88.9 x 3.2 mmØ	1.7
81600/1-139.7 x 4.0 x 76.1 x 2.9 mmØ	1.7
81600/1-139.7 x 4.0 x 60.3 x 2.9 mmØ	1.7
81600/1-168.3 x 4.5 x 139.7 x 4.0 mmØ	2.5
81600/1-168.3 x 4.5 x 133.0 x 4.0 mmØ	2.5
81600/1-168.3 x 4.5 x 114.3 x 3.6 mmØ	2.5
81600/1-168.3 x 4.5 x 88.9 x 3.2 mmØ	2.5
81600/1-168.3 x 4.5 x 76.1 x 2.9 mmØ	2.5
81600/1-168.3 x 4.5 x 60.3 x 2.9 mmØ	2.5
81600/1-219.1 x 6.3 x 168.3 x 4.5 mmØ	5.0
81600/1-219.1 x 6.3 x 159.0 x 4.5 mmØ	5.0
81600/1-219.1 x 6.3 x 139.7 x 4.0 mmØ	5.0
81600/1-219.1 x 6.3 x 133.0 x 4.0 mmØ	5.0
81600/1-219.1 x 6.3 x 114.3 x 3.6 mmØ	5.0
81600/1-219.1 x 6.3 x 108.0 x 3.6 mmØ	5.0
81600/1-219.1 x 6.3 x 88.9 x 3.2 mmØ	5.0
81600/1-273.0 x 6.3 x 219.1 x 6.3 mmØ	7.5
81600/1-273.0 x 6.3 x 168.3 x 4.5 mmØ	7.5
81600/1-273.0 x 6.3 x 159.0 x 4.5 mmØ	7.5
81600/1-273.0 x 6.3 x 139.7 x 4.0 mmØ	7.5
81600/1-273.0 x 6.3 x 133.0 x 4.0 mmØ	7.5
81600/1-273.0 x 6.3 x 114.3 x 3.6 mmØ	7.5
81600/1-323.9 x 7.1 x 273.0 x 6.3 mmØ	11.0
81600/1-323.9 x 7.1 x 267.0 x 6.3 mmØ	11.0
81600/1-323.9 x 7.1 x 219.1 x 6.3 mmØ	11.0
81600/1-323.9 x 7.1 x 168.3 x 4.5 mmØ	11.0
81600/1-323.9 x 7.1 x 159.0 x 4.5 mmØ	11.0
81600/1-323.9 x 7.1 x 139.7 x 4.0 mmØ	11.0



baelz 81900

Dished ends

DIN 28011

Material: P265GH - 1.0425

Design: made of cold formed sheet metal,
edge VA (V-seam external)
with hard stamping

Weights baelz 81900

Baelz type	Weight (kg)
81900-21.3 x 3 mmØ	0.05
81900-26.9 x 3 mmØ	0.06
81900-33.7 x 3 mmØ	0.07
81900-42.4 x 3 mmØ	0.08
81900-48.3 x 3 mmØ	0.2
81900-60.3 x 3 mmØ	0.2
81900-76.1 x 3 mmØ	0.3
81900-88.9 x 3 mmØ	0.4
81900-114.3 x 4 mmØ	0.7
81900-139.7 x 4 mmØ	1.0
81900-168.3 x 5 mmØ	1.7
81900-219.1 x 6 mmØ	3.3
81900-273.0 x 6 mmØ	4.8
81900-323.9 x 7 mmØ	7.6



baelz 85850

Water seals

to protect manometers from overheating.

For baelz Bourdon tube manometers and for baelz 826, 828, 831 and 835

Consisting of: 1 x siphon
1 x manometer isolating valve seals

Temperature/Pressure: max. 200 °C/25 bar

Weight approx.: 0.8 kg

baelz 85850 In steel			
Baelz type	Manometer tube		Manometer valve
85850-WSR	Siphon right, St 35.8	K30002936	Manometer isolating valve baelz 70075
85850-WSL	Siphon left, St 35.8	K30002937	Manometer isolating valve baelz 70075
85850-WSK	Siphon circular, St 35.8	K30000174	Manometer isolating valve baelz 70075
baelz 85850 In stainless steel			
85850-WSR-VA	Siphon right, 1.4571	F20001735	Manometer isolating valve baelz 70075-VA-TW
85850-WSL-VA	Siphon left, 1.4571	F20001736	Manometer isolating valve baelz 70075-VA-TW
85850-WSK-VA	Siphon circular, 1.4571	K30002120	Manometer isolating valve baelz 70075-VA-TW

baelz 85892

Water seals

to protect manometers from overheating.

For safety pressure switches baelz 834

Consisting of: 1 x siphon
seals

Temperature/Pressure: max. 200 °C/25 bar

Weight approx.: 0.3 kg



baelz 85892 in steel		
Baelz type	Manometer tube	
85892-WSR	Siphon right, St 35.8	K30002936
85892-WSL	Siphon left, St 35.8	K30002937
85892-WSK	Siphon circular, St 35.8	K30000174
baelz 85892 in stainless steel		
85892-WSR-VA	Siphon right, 1.4571	F20001735
85892-WSL-VA	Siphon left, 1.4571	F20001736
85892-WSK-VA	Siphon circular, 1.4571	K30002120



baelz 85950

baelz 85950

STUFFING BOX HEATING

- protects the valve spindle against icing up
- for fluid temperatures between -10...- 40°C
- junction box optional

APPLICATION

Standard version for spindle Ø10 mm or Ø16 mm
For spindle Ø22 mm on request

Technical specifications, baelz 85950

Power supply	12-24 V AC/DC or 110-230 V AC/DC	
Maximum power (W)	20	
Ambient temperature (°C)	-20...+50	
Cable length (mm)	2000	
Protection rating	SK II	
Dimensions (approx., mm)	70 x 67 x 15	
Weight (approx., kg)	0.1	
Accessories		
Type baelz	Spindle Ø (mm)	Power supply
85950-AD-HZ-10/16-12-24V AC/DC	10 or 16	12-24 V AC/DC
85950-AD-HZ-10/16-110-230V AC/DC	10 or 16	110-230 V AC/DC
85950-AD-HZ-22-12-24V AC/DC	22	12-24 V AC/DC
85950-AD-HZ-22-110-230V AC/DC	22	110-230 V AC/DC
Accessories		
Type baelz	Description	Remarks
ZB85950-KG	Junction box, gray, 89x43x37 mm	for mounting on yoke, ingress protection rating IP55

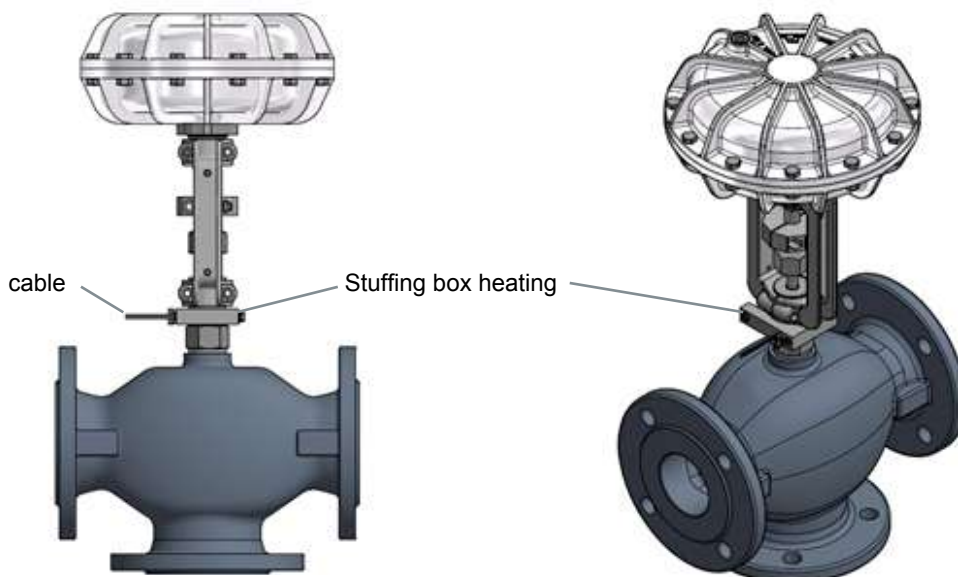

Mounting example baelz 85950

Spare parts for baelz 185.....	296
Spare parts for baelz 192.....	296
Spare parts for baelz 206r.....	297
Spare parts for baelz 265st-SK3.....	297
Spare parts for baelz 265st-K16-230.....	297
Spare parts for baelz 334 / 334-1 and 335 / 335-1.....	298
Spare parts for baelz 340-2/342-2/347-2... Without bellows seal.....	298
Spare parts for baelz 340-2/342-2/347-2... With bellows.....	299
Spare parts for baelz 356.....	300
V-ring packing sets in PTFE for spindle Ø 10 mm.....	301
V-ring packing sets in PTFE for spindle Ø 10/16 mm.....	302
V-ring packing sets in PTFE for spindle Ø 16/16 mm.....	302
V-ring packing sets in PTFE for spindle Ø 16 mm.....	302
V-ring packing sets in PTFE for spindle Ø 22 mm.....	303
V-ring packing sets in PTFE including wiper set.....	304
Spare parts for baelz 373-E07.....	305
Spare parts for baelz 373-E11.....	305
Spare parts for baelz 373-E40.....	305
Spare parts for baelz 373-E45.....	305
Replacement capacitors and limit switches.....	305
Spare parts for pneumatic actuators baelz 373-P21... and P22.....	306
Spare parts for pneumatic actuators baelz 373-P31/P32... and P41.....	307
Aluminum yoke S21... / Stainless steel yoke S23 / Galvanized steel yoke S41.....	308
Spare parts for baelz 375-E03-40-3.....	309
Spare parts for baelz 375-E03-20-0,7.....	309
Spare parts for baelz 375-E03-12-0.25.....	309
Spare parts for baelz 375-E41-150-1.....	309
Spare parts for baelz 471/471-1...4.....	310
Spare parts for baelz 475, 480 and 590.....	310
Lubricating and assembly pastes.....	311

Spare parts for baelz 185

Product	Data / Notes	
Strainer screen	If the strainer screen is replaced, we recommend replacing the seal set (order No. 99185-031) as well.	
Plug stem	Seat Ø 2.5...10mm	Kvs 0.025...1.4
PTFE plug stem	Seat Ø 3...10 mm	Kvs 0.3...1.4 PTFE/VA soft seal, max. 240 °C
Screw seat	Seat Ø 2.5...10 mm	for plug stem
Screw seat	Seat Ø 2...10 mm	Version for control elements
V-ring packing in PTFE	Consisting of: 1 set of V-rings in PTFE Ø 10 mm 1 shim ring 12 x 18 x 0.5 1 pressure spring KT 8948 2 DU bushings 1010	
Connecting piece	including threaded pin DIN 913, G 1/8 x 8	(order No. F20000207)
Seal set complete	for screw seat and screw plug holes	(order No. 99185-031)



Strainer screen



Plug stem



Screw seat

Spare parts for baelz 192

Product	Data	
Diaphragm (flat diaphragm)	DN 15...150	
Diaphragm (shaped diaphragm)	DN 80...150	
Plug stem	DN 15...125	
Perforated plug stem	DN 15...125	Kvs 2.5...100
Control head VU-VA	DN 15...125	PN 16, PN 40



Flat diaphragm



Shaped diaphragm



Control head



Fixing bracket for control head

Spare parts for baelz 206r

Product	Data / Notes
Diaphragm	99 x 2 mm Ø / 129 x 2 mm Ø
Plug stem complete	for stem length 100, 200, 300 mm including rivet pin DIN 7341-M3 x 10 Sealing ring DIN 7063 21 x 26 x 2 mm Hexagon nut M6
Plug	including rivet pin DIN 7341-B3 x 10
Metal bellows seal assembly	



Metal bellows seal assembly

Spare parts for baelz 265st-SK3

Product	Data
Solenoid complete	230 V, 50 Hz
Plug stem complete	For seat Ø 2.5, 3, 4 and 5 mm; consisting of: Plug stem KT 9640 Holder KT 9434 Anchor KT 22594 Rivet pin
Plug stem	For seat Ø 2.5, 3, 4 and 5 mm

Spare parts for baelz 265st-K16-230

Product	Data
Solenoid complete	230 V, 50 Hz
Spindle	For seat Ø 6, 8 and 10 mm
Plug	For seat Ø 6 and 8 mm, for seat Ø 10 mm

Spare parts for baelz 334 / 334-1 and 335 / 335-1

Nominal pressure PN 16 / 25

Product	Data / Notes	
Plug stem	G ½... G 1½	Kvs 3.53... 22
V-ring packing in PTFE for baelz 335	Consisting of:	1 set of V-rings in PTFE 10 x 18 x 10.4 mm 2 shim rings 12 x 18 x 0.5 1 pressure spring KT 9417 2 DU bushings 1010
V-ring packing in PTFE for baelz 335-1	Consisting of:	1 set of V-rings in PTFE 10 x 18 x 10.4 mm, including wiper set 2 shim rings 12 x 18 x 0.5 1 pressure spring KT 9417 2 DU bushings 1010
O-ring	EPDM 44 x 2 mm / 48 x 2 mm	
Socket seals (1 set)	G ½... G 1½	
Weld-on sockets	G ½... G 1½	
Stainless steel weld-on sockets	G ½... G 1½	
Threaded sockets 2-fold	G ½...G1	for two-way valves
Threaded sockets 3-fold	G ½...G1	for three-way valves
Union nut	G ¾...G2	

Spare parts for baelz 340-2/342-2/347-2... Without bellows seal

Nominal pressure PN 16, 25 and 40 or as specified in quote

Product	Data / Notes	
Plug stem for 340-2/342-2/347-2-B 340-2/342-2/347-2-BK	DN 15...125	Kvs 2...200
Plug stem for 340-2/347-2-B 340-2/347-2-AI-BB 340-2/347-BBK 340-2/347-2-AI-BBK	DN 150, DN 200	Kvs 360, Kvs 580
Union nut	DN 15...125	
Connecting piece	For DN 15...125	
Grooved ring	For DN 15...125	
Spring support	For DN 15...125 / DN 150...250	
Nameplate	For DN 15...125	
Round-head grooved pin	For DN 15...125	
Threaded pin (G 1/8)	For DN 15...125	

Note: If the spindle surface is damaged, the plug spindle must also be replaced.
Cooling tubes and seat bushings DN 15...125 see spare parts baelz 340-2/342-2... With bellows seal
Replacement seals for valves DN 150...250, see spare parts baelz 347-2... With bellows
V-ring sets see baelz 91030...



Plug stem

Spare parts for baelz 340-2/342-2/347-2... With bellows

Nominal pressure PN 16, 25 and 40 or as specified in quote

Product	Data / Notes		
Cooling tubes for 340-2/342-2/347-2-BK 340-2/342-2/347-2-BK-SS	DN 15...125		
Plug for 340-2/342-2-BK-SS 347-2-BK-SS	DN 15...25	Kvs 2...9	
Plug for 340-2/342-2-BK-SS 347-2-BK-SS	DN 32, 40	Kvs 16, 25	including connecting nut
Plug for 340-2/342-2-BK-SS 347-2-BK-SS	DN 50...125	Kvs 36...200	including connecting nut M18 x 1.5
Bellows spindle complete (without plug)	DN15...25 / DN 32...125		for external pressure max. 16 bar consisting of: spindle, bellows (single-walled), union screw and cutting ring Note: If the bellows spindle is replaced, we recommend replacing the pressure ring Order No. 95850-276 and the V-ring set Order No. 91030-001 as well.
Connecting piece	For DN 15...125		
Grooved ring	For DN 15...125		
Pressure ring	For DN 15...125 / DN 150...250		
Nameplate	For DN 15...125		
Round-head grooved pin	For DN 15...125		
Threaded pin (G 1/8)	For DN 15...125		
Seat bushing for 340-2/342-2-BK 340-2/342-2-BK-SS	DN 15...125	for PN 40	Seat bushing reqd. for body DN15...125, PN40
Seat bushing for 347-2-B, -BK, BK-SS	DN 15...125		
Seal for seat bushing for 347-2-B, -BK, BK-SS	DN 32...125		Seat bushings DN 15...25 do not require a separate seal.
Plug for 340-BBK-SS/AI-BBK-SS 347-BBK-SS/AI-BBK-SS	DN 150...250	Kvs 360...960	
Bellows spindle complete (without plug)	DN 150...250		for external pressure max. 25 bar Consisting of: spindle, bellows (double-walled), union screw KT 9365 and cutting ring Ø22 mm Note: If the bellows spindle is replaced, we recommend replacing the V-ring set No. 91030... as well.
Grooved ring	For DN 150...250		
Pressure ring			
Seal for 340-2/347-BB, BBK, BBK-SS	DN 200, DN 250	PN 16/25	for sealing the 3rd way (not for series AK-BBK-SS)
Cover seal for 340-2/347-BB, BBK, BBK-SS	DN 150...250	PN 16/25	

Components of "Bellows spindle complete (without plug)"



Spindle



2-walled bellows



Union screw



Cutting ring

Spare parts for baelz 356...

Nominal pressure PN 16, 25 and 40

Product	Data / Notes		
Plug stem	DN 15...65	Kvs 1...63	Materials: plug 1.4571; spindle 1.4021
Perforated plug stem	DN 15...65	Kvs 2...50	Materials: plug 1.4571; spindle 1.4021
Connecting piece	DN 15...65		stainless steel 1.4104, incl. threaded pin DIN 913, G1/8 x 8 upon request (spare part for baelz 480)

V-ring packing sets in PTFE for spindle Ø 10 mm

Order number	Fittings	Nominal diameter	Components
91030-001	340-2..., 342-2..., 347-2..., 353... 340-2/347-2-B-EMF 344 346-EMB... 354 356 356-K 358/359-K 360-C 360-EM-C	DN 15...125 DN 40...80 DN 32...80 DN 40...125 DN 32...80 DN 15...32 DN 15...65 DN 15...65 DN 25 DN 32 + 40	1 set of V-rings in PTFE 10 x 18 x 10.4 2 shim rings 12 x 18 x 0.5 1 pressure spring KT 9417 1 DU bushing for union nut 1010 1 DU bushing for threaded connector 1015
91030-021	340-2..., 342-2..., 347-2..., 353... 340-2/347-2-B-EMF 344 346-EMB... 354 356 356-K 358/359-K 360-C 360-EM-C	DN 15...125 DN 40...80 DN 32...80 DN 40...125 DN 32...80 DN 15...32 DN 15...65 DN 15...65 DN 25 DN 32 + 40	1 set of V-rings in PTFE 10 x 18 x 10.4 (PTFE pure white) 2 shim rings 12 x 18 x 0.5 1 pressure spring KT 9417 1 DU bushing for union nut 1012-12 1 DU bushing for threaded connector 1012-12
91030-004	356/356-AI	DN 40...65	1 set of V-rings in PTFE 10 x 18 x 10.4 1 shim ring 12 x 18 x 0.5 1 pressure spring KT 9417 1 DU bushing for union nut 1010 1 DU bushing for threaded connector 1015
91030-051	480/480-K 590/590-K 585	DN 15...125 DN 15...125 DN 15...50	1 set of V-rings in PTFE 10 x 18 x 10.4 1 shim ring 12 x 18 x 0.5 1 supporting ring DIN 125 A13 1 pressure spring KT 9417 1 DU bushing 1010 1 DU bushing 1015 / 2015 (480) 1 MBZ bushing 1015 / 2015 (585, 590)

Note: Information on our packing sets can be found in our operating instructions MBA 334-367.
If the spindle surface is damaged, the plug spindle must also be replaced.



Example of a V-ring packing in PTFE set (order No. 91030-001)

V-ring packing sets in PTFE for spindle Ø 10/16 mm

Order number	Fittings	Nominal diameter	Spindle Ø (mm)	Components
91030-161	591/591-K	DN 32...80	10/16	1 set of V-rings in PTFE 10 x 18 x 10.4 2 shim rings 12 x 18 x 0.5 1 pressure spring KT 9417 1 disk DIN 125 A13 1 DU bushing for union nut 1010 1 MBZ bushing for threaded connector 2015 2 sets of V-rings in PTFE 16 x 26 x 12.7 1 shim ring KT 22981 1 supporting ring KT 24329 1 pressure spring KT 22973

V-ring packing sets in PTFE for spindle Ø 16/16 mm

Order number	Fittings	Nominal diameter	Spindle Ø (mm)	Components
91030-162	591/591-K	DN 100...125	16/16	1 DU bushing for union nut 1615 1 MBZ bushing for threaded connector 2015 3 sets of V-rings in PTFE 16 x 26 x 12.7 2 shim rings KT 22981 2 supporting rings KT 24329 2 pressure springs KT 22973

V-ring packing sets in PTFE for spindle Ø 16 mm

Order number	Fittings	Nominal diameter	Spindle Ø (mm)	Components
91030-052	344 480/480-K 585 590/590-K 590, stroke 40 mm	DN 100 + 125 DN 100 + 125 DN 65...125 DN 100 + 125 DN 150...200	16	1 set of V-rings in PTFE 16 x 26 x 12.7 1 shim ring KT 22981 1 supporting ring KT 24329 1 pressure spring KT 22973 1 DU bushing 1615 1 DU bushing 2015 (480) 1 MBZ bushing 2015 (585, 590)
91030-003	340-2/347-2-B-EMF 360-EM-C/CC	DN 100 + 125 DN 50...125	16	1 set of V-rings in PTFE 10 x 18 x 10.4 1 shim ring 12 x 18 x 0.5 1 supporting ring DIN 125, A13 1 pressure spring KT 9417 1 DU bushing 1010 1 DU bushing 2015 (480) 1 MBZ bushing 2015 (585, 590)

Note: Information on our packing sets can be found in our operating instructions MBA 334-367.
If the spindle surface is damaged, the plug spindle must also be replaced.

V-ring packing sets in PTFE for spindle Ø 22 mm

Order number	Fittings	Nominal diameter	Components
91030-101	340-2/347-BB, BB-EMF, AI-BB 340-2/347-2-AI-BB 346-22 346-EMB 346-EM-C/CC	DN 150...300 DN 150...300 DN 65...125 DN 150 DN 150...200	1 set of V-rings in PTFE 22 x 34 x 20.5 2 supporting rings KT 22784 1 pressure spring KT 22764 1 DU bushing for spindle guide 2215 1 DU bushing for pressure screw 2215
91030-102	340-2/347-BBK 340-2/347-2-AI-BBK	DN 150...300 DN 150...300	1 set of V-rings in PTFE 22 x 34 x 20.5 1 supporting ring KT 22784 1 pressure spring KT 22764 1 DU bushing 2215 1 pressure ring KT 26327
91030-103	340-2/347-BBK-SS 340-2/347-2-AI-BBK-SS	DN 150...300 DN 150...300	1 set of V-rings in PTFE 22 x 34 x 20.5 1 supporting ring KT 22784 1 pressure spring KT 22764 1 DU bushing 2215 1 pressure ring KT 26327
91030-153	480/480-K 590/590-K	DN 150...300 DN 150...300	1 set of V-rings in PTFE 22 x 34 x 20.5 2 supporting rings KT 22784 1 pressure spring KT 22764 1 DU bushing for spindle guide 2215 1 DU bushing for pressure screw 2215
91030-163	591/591-K	DN 150...200	3 sets of V-rings in PTFE 22 x 34 x 20.5 4 supporting rings KT 22784 2 pressure springs KT 22764 1 DU bushing for pressure screw 2215

Note: Information on our packing sets can be found in our operating instructions MBA 334-367.
If the spindle surface is damaged, the plug spindle must also be replaced.

V-ring packing sets in PTFE including wiper set

Order number	Fittings	Nominal diameter	Spindle Ø (mm)	Components
91030-071	480/480-K 590/590-K	DN 15...50	Spindle Ø 10 mm, nozzle Ø ≤12,5 mm	1 set of V-rings in PTFE 10 x 18 x 10.4 1 shim ring 12 x 18 x 0.5 1 supporting ring DIN 125 A13 1 pressure spring KT 9417 1 DU bushing 1010 1 DU bushing 1015 / 2015 (480) 1 MBZ bushing 1015 / 2015 (590) additionally: 1 shim ring 12 x 18 x 0,5 1 profile set Ø10-N2 1 threaded connector KT 27834
91030-072	480/480-K 590/590-K	DN 32...80	Spindle Ø 10 mm, nozzle Ø ≥16 mm	1 set of V-rings in PTFE 10 x 18 x 10.4 1 shim ring 12 x 18 x 0.5 1 supporting ring DIN 125 A13 1 pressure spring KT 9417 1 DU bushing 1010 1 DU bushing 1015 / 2015 (480) 1 MBZ bushing 1015 / 2015 (590) additionally: 1 shim ring 12 x 18 x 0,5 1 profile set Ø10-N2 1 ring insert KT 27826 1 threaded connector KT 27834
91030-073	480/480-K 590/590-K	DN 100...125	Spindle-Ø 16 mm	1 set of V-rings in PTFE 16 x 26 x 12,7 1 shim ring KT 22981 1 supporting ring KT 24329 1 pressure spring KT 22973 1 DU bushing 1615 1 DU bushing 2015 (480) 1 MBZ bushing 2015 (590) additionally: 2 shim rings KT 2298 1 profile set Ø16-N2 1 threaded connector KT 26973

Note: Information on our packing sets can be found in our operating instructions MBA 334-367.
If the spindle surface is damaged, the plug spindle must also be replaced.

Spare parts for baelz 373-E07

Order number	Product	Data / Notes
99373-051	Motor type RSM63/8 SG including motor pinion KT 24669 and capacitor as specified	C: 0.36 μ F/500 V incl. 100 Ω /1 W 230 V, 50/60 Hz (220...240 V)
99373-053		C: 1.65 μ F/250 V incl. 18 Ω /0.25 W 115 V, 50/60 Hz
99373-055		C: 0.36 μ F/63 V 24 V, 50/60 Hz

Drive, elevating spindle and intermediate ring available on request



Motor



Capacitor



load-dependent limit switches

Spare parts for baelz 373-E11

Available on request:	motor type RSM63/8 SG incl. motor pinion KT 24669 and capacitor Diode board with integrated capacitor Solenoid including diode board and capacitor Elevating spindle
------------------------------	---

Note: Replacement yokes see order no. 99.OS373-923/924
For a smooth process, please indicate the exact data of the nameplate when ordering.

Spare parts for baelz 373-E40

Order number	Product	Data / Notes
99373-091	Motor type RSM842/3F (replacement for RSM 842/3ANK) including motor pinion KT 9340 and capacitor as specified	C: 0.6 μ F/400 V incl. 100 Ω /1 W 230 V, 50/60 Hz (220...240 V)
99373-093		C: 2.5 μ F/200 V incl. 10 Ω /0.25 W 115 V, 50/60 Hz (110...120 V)
99373-095		C: 48 μ F/45 V 24 V, 50/60 Hz

Potentiometer pinion (please order guide), elevating spindle and threaded sleeve available on request

Spare parts for baelz 373-E45

Available on request:	Motor Board complete, including capacitor - When converting to a different voltage, also order the corresponding board.
------------------------------	--

Replacement capacitors and limit switches

available on request

Spare parts for pneumatic actuators baelz 373-P21... and P22...

Product	Data / Notes	
NBR rolling diaphragm and clamping band	Stainless steel clamping band	
Silicone diaphragm and clamping band	Stainless steel clamping band	For ambient temperatures up to max. 100 °C
Clamping band	Stainless steel	
Seal set complete for 373-P21.../P22...	Consisting of:	O-ring 38 x 2.5 NBR-WS 636 2 DU bushings 1215 DU-B 1 sealing element QHLP12x22 NBR-80118 2 snap ring 7993-B18
Seal set complete for 373-P21L.../P22L...	Consisting of:	O-ring 38 x 2.5 NBR-WS 636 2 DU bushings 1215 DU-B 1 sealing element QHLP12x22 NBR-80118 1 snap ring 7993-B22
Diaphragm plate	for baelz 373-P21... and P22...	
Spindle	Stainless steel	Take actuator type and operating direction into account when ordering
Pressure spring	Take actuator type and operating direction into account when ordering	

Note: Replacement yokes see order no. 99.0S373-923/-924



NBR rolling diaphragm and clamping band



Silicone diaphragm and clamping band



Pressure spring



Diaphragm plate



Seal set

Spare parts for pneumatic actuators baelz 373-P31/P32... and P41...

Product	Data / Notes	
NBR rolling diaphragm and clamping band for baelz 373-P31/P32...	Stainless steel clamping band incl. 2 x DIN 912 M5 x 25	
NBR rolling diaphragm and clamping band for baelz 373-P41...	Stainless steel clamping band incl. 2 x DIN 912 M6 x 30	
Clamping band for baelz 373-P31/P32...	Stainless steel	incl. 2 x DIN 912 M5 x 25
Clamping band for baelz 373-P41...	Stainless steel	incl. 2 x DIN 912 M6 x 30
Seal set complete	Consisting of: 2 DU bushings 2225 DU-B 1 sealing element QHLP22-32 NBR-80118 2 snap ring 7993-B32	
Diaphragm plate	for baelz 373-P31... and P32... / for baelz 373-P41... and P41-V6 (note actuator type)	
Spindle	Stainless steel	Take actuator type and operating direction into account when ordering
Pressure spring	Take actuator type and operating direction into account when ordering	

Note: Replacement yokes see order no. 99.0S373-911...922



NBR rolling diaphragm and clamping band for baelz 373-P31/P32...



NBR rolling diaphragm and clamping band for baelz 373-P41...



Pressure spring



Seal set

Aluminum yoke S21... / Stainless steel yoke S23 / Galvanized steel yoke S41...

Aluminum yokes S21/S21L	Standard model incl. coupling and fixing screws, galvanized steel
Aluminum yokes S21-BS/S21-L-BS	With polyester coating incl. coated coupling, color black RAL 9005, stainless steel fixing screws
Stainless steel yoke S23	Incl. coupling and fixing screws, for spindle Ø max. 16 mm, stroke max. 40 mm For motor actuators 373-E66-80-25... For high differential pressures
Galvanized steel yoke S41...	Incl. coupling and fixing screws, for spindle Ø 22mm For pneumatic actuators baelz 373-P31, -P32 and -P41 and motor actuators 373-E45, -E66 (DN 150) and -E88 (from DN 150)
Order number	Data / Notes
99.0S373-923	Aluminium yoke S21 for control valves with spindle Ø 10 mm (G1/8)
99.0S373-923-BS	Aluminium yoke S21, polyester coated, for control valves with spindle Ø 10 mm (G1/8)
99.0S373-924	Aluminium yoke S21-L for control valves with spindle Ø 16 mm (M12)
99.0S373-924-BS	Aluminium yoke S21-L, polyester coated, for control valves with spindle Ø 16 mm (M12)
99.0E373-902	Handwheel for electric and pneumatic actuators or for manual change of stroke using manual release on motor actuators. Consisting of: 2 x hand wheel segment KT 7691 2 x DIN 912 M6 x 30 - 8.8 2 x DIN 934 M6
99.0S373-925	Stainless steel yoke S23 for control valves with spindle Ø max. 16 mm
99.0S373-921	Galvanized steel yoke S41 for control valves without cooling tube
99.0S373-922	Galvanized steel yoke S41C for control valves with cooling tube
99.0S373-931	Coupling for steel yokes S41 and S41C Consisting of: coupling KT 9616 2 lugs KT 8015 metal plate KT 8182 8x DIN 125A - 8.4 galv. 4 x DIN EN ISO 4017 M8 x 70 - 8.8 galv. 4 x DIN EN ISO 4029 M6 x 8 - 45H galv. 4 x DIN 985 M8 - 8.8 galv.



Aluminium yoke S21
(built-in)



Steel yoke S41
(built-in)



Stainless steel yoke S23
(built-in)

Spare parts for baelz 375-E03-40-3

Order number	Product	Data / Notes
99375-001	Motor for rotary actuator type RSM 51/8 (replacement for RSM 50/8 FG) incl. motor pinion KT 5479 and capacitor as specified	C: 0.2 µF/500 V incl. 100 Ω/1 W 230 V, 50/60 Hz
99375-003		C: 0.82 µF/200 V incl. 33 Ω/0.25 W 115 V, 50/60 Hz
99375-005		C: 20 µF/40 V 24 V, 50/60 Hz

Spare parts for baelz 375-E03-20-0,7

Order number	Product	Data / Notes
99375-011	Motor for rotary actuator type RSM 51/8 (replacement for DRSM 50/8 ES NG) incl. motor pinion KT 5479 and capacitor as specified	C: 0.2 µF/500 V incl. 100 Ω/1 W 230 V, 50/60 Hz
99375-013		C: 0.82 µF/200 V incl. 33 Ω/0.25 W 115 V, 50/60 Hz
99375-015		C: 20 µF/40 V 24 V, 50/60 Hz

Spare parts for baelz 375-E03-12-0.25

Order number	Product	Data / Notes
99375-021	Motor for rotary actuator type RSM 51/8 incl. motor pinion KT 5479 and capacitor as specified	C: 0.2 µF/500 V incl. 100 Ω/1 W 230 V, 50 Hz
99375-022		C: 0.2 µF/500 V incl. 100 Ω/1 W 230 V, 60 Hz
99375-023		C: 0.82 µF/200 V incl. 33 Ω/0.25 W 115 V, 50 Hz
99375-024		C: 0.82 µF/200 V incl. 33 Ω/0.25 W 115 V, 60 Hz
99375-025		C: 20 µF/40 V 24 V, 50 Hz
99375-026		C: 20 µF/40 V 24 V, 60 Hz

Spare parts for baelz 375-E41-150-1

Order number	Product	Data / Notes
99375-053	Motor for rotary actuator type RSM 51/8 (replacement for DRSM 50/8 ES NG) incl. motor pinion KT 5479 and capacitor as specified	C: 0.68 µF/500 V incl. 100 Ω/1 W 230 V, 50/60 Hz
99375-055		C: 2.7 µF/250 V incl. 50 Ω/0.25 W 115 V, 50/60 Hz
99375-057		C: 57 µF/63 V 24 V, 50/60 Hz
99375-3823	Board complete	with capacitor 0.68 µF 230 V, 50/60 Hz
99375-3236	Stem gear	

Note: For a smooth process, please indicate the exact data of the nameplate when ordering.

Spare parts for baelz 471/471-1...4

Nominal pressure PN 16 / 25

Product	Data / Notes	
Plug stem	Suitable for G ½... G 1½	Seat Ø 3...16 mm
Connection cover	Suitable for G ½... G 1½	Nozzle Ø 3...16 mm
Spring cage	for baelz 471/471-1...3 / for baelz 471-4	
Pressure screw	for baelz 471/471-1...3 / for baelz 471-4	
Connecting piece		
V-ring packing in PTFE for baelz 471/471-1...3	Consisting of:	1 set of V-rings in PTFE 10 x 18 x 10.4 mm 2 shim rings 12 x 18 x 0.5 1 pressure spring KT 9417 2 DU bushings 1010
V-ring packing in PTFE for baelz 471/471-4	Consisting of:	1 set of V-rings in PTFE 10 x 18 x 10.4 mm incl. wiper set 2 shim rings 12 x 18 x 0.5 1 pressure spring KT 9417 2 DU bushings 1010
O-rings	EPDM 44 x 2 mm (order No. K30000437) / EPDM 48 x 2 mm (order No. K30000566)	
Socket seals	G ½... G 1½	Consisting of 4 special seals
Weld-on sockets	G ½... G 1½	Steel St. 37
Stainless steel weld-on sockets	G ½... G 1½	
Threaded sockets 3-fold	G ½... G 1	Brass
Union nuts	G ¾...G2 (for G ½... G 1½)	Brass

Spare parts for baelz 475, 480 and 590

For spare parts for baelz 475, 480 and 590, nozzle drivers for disassembly/assembly of baelz 480 and 590 nozzles and universal keys, please don't hesitate to get in touch with Baelz.

Please note that when exchanging the plug stem 480-1 for 480-3, from nozzle Ø 16 mm, the threaded connector KT 9412 must be exchanged for KT 22824.

From DN 80, the threaded connector KT 22824 is already included with 480-1, regardless of the nozzle diameter, so that no replacement is required.

V-ring sets see baelz 91030...



Union nut for baelz 480



Connecting piece for baelz 480



Threaded connector for baelz 480



Diffuser seal for baelz 480



Nozzle for baelz 480



Head piece for baelz 475



Nozzle driver for baelz 480 and 590

Lubricating and assembly pastes

Order number	Product	Data / Notes
92000-001	High-performance grease paste, silicone-free 70 g cartridge	For V-ring sets
92000-101	High-performance grease paste, silicone-free 50 g can	For drive spindles (apply thinly)
G51000462	Assembly paste 150 ml	For extremely high temperatures -20 °C...1200 °C For light assembly/disassembly work / tight-fit connections For plugs, threads, screws, nuts, bolts, etc. (not suitable as lubricant for moving parts such as sliding bearings, roller bearings, etc.) corrosion-inhibiting, prevents seizure, waterproof, silicone-free (apply thinly)
92300-001	Assembly paste 50 g can	White high-temperature lubricating and assembly paste, max. 1200 °C For food, drinking water and pharmaceutical industry NSF H1 registered (meets FDA requirements) For light assembly/disassembly work For plugs, threads, screws, nuts, bolts, etc. corrosion-inhibiting, prevents seizure, waterproof, silicone-free (apply thinly)



Assembly paste Order No. 92000-001



Assembly paste Order No. 92000-101 / 92300-001



Assembly paste Order No. G51000462

11.1 Max. pressures and temperatures according to DIN EN 1092

Pressure and Temperature Table according to DIN EN 1092-2 - Material: EN-GJS-400-18-LT ²⁾										
PN	max. pressure (PS) in bar at temperature in °C									
	120 ¹⁾	150	200	240 ³⁾	250	260 ³⁾	290 ³⁾	300	315 ³⁾	350
16	16,0	15,5	14,7	14,0	13,9	13,6	13,0	12,8	12,3	11,2
25	25,0	24,3	23,0	22,0	21,8	21,4	20,3	20,0	19,2	17,5

¹⁾ admissible from -10 °C to +120 °C

²⁾ formerly GGG 40.3

³⁾ Intermediate values determined by linear interpolation

Pressure and Temperature Table according to DIN EN 1092-1 - Material: P250GH ²⁾ ; GP240GH ³⁾ ; P235GH ⁴⁾														
PN	max. pressure (PS) in bar at temperature in °C													
	RT ¹⁾	100	120 ⁵⁾	150	200	240 ⁵⁾	250	260 ⁵⁾	290 ⁵⁾	300	315 ⁵⁾	350	400	450
16	16	14,8	14,4	14	13,3	12,3	12,1	11,8	11,2	11,0	10,7	10,2	9,5	5,2
25	25	23,2	22,7	22,0	20,8	19,3	19,0	18,6	17,5	17,2	16,8	16,0	14,8	8,2
40	40	37,1	36,3	35,2	33,3	30,9	30,4	29,8	28,1	27,6	27,0	25,7	23,8	13,1
63	63	58,5	57,3	55,5	52,5	48,9	48,0	47,1	44,4	43,5	42,6	40,5	37,5	20,7
100	100	92,8	90,8	88,0	83,3	77,5	76,1	74,6	70,4	69,0	67,5	64,2	59,5	32,8
160	160	148,5	145,4	140,9	133,3	124,1	121,9	119,6	112,7	110,4	108,1	102,8	95,2	52,5

¹⁾ admissible for room temperatures from -10 °C to +50 °C

²⁾ formerly C22.8

³⁾ formerly GS-C25

⁴⁾ formerly St 35.8

⁵⁾ Intermediate values determined by linear interpolation

Pressure and Temperature Table according to DIN EN 1092-1 - Material: 1.4571															
PN	max. pressure (PS) in bar at temperature in °C														
	RT ¹⁾	100	120 ³⁾	150	200	240 ³⁾	250	260 ³⁾	290 ³⁾	300	315 ³⁾	350	400	450 ²⁾	500 ²⁾
16	16,0	16,0	15,8	15,6	14,9	14,2	14,1	13,9	13,4	13,3	13,1	12,8	12,4	12,2	12,0
25	25,0	25,0	24,8	24,5	23,3	22,3	22,1	21,8	21,0	20,8	20,5	20,1	19,5	19,1	18,8
40	40,0	40,0	39,6	39,2	37,3	35,7	35,4	34,9	33,7	33,3	32,9	32,1	31,2	30,6	30,0

¹⁾ admissible for room temperatures from -10 °C to +50 °C

²⁾ above 400 °C intercrystalline corrosion occurs

³⁾ Intermediate values determined by linear interpolation

Pressure and Temperature Table according to DIN EN 1092-1 - Material: 1.4408													
PN	max. pressure (PS) in bar at temperature in °C												
	RT ¹⁾	100	120 ³⁾	150	200	240 ³⁾	250	260 ³⁾	290 ³⁾	300	315 ³⁾	350 ²⁾	400 ²⁾
16	16,0	16,0	15,4	14,5	13,4	12,8	12,7	12,5	11,9	11,8	11,6	11,4	10,9
25	25,0	25,0	24,5	22,7	21,0	20,0	19,8	19,5	18,7	18,5	18,2	17,8	17,1
40	40,0	40,0	39,2	36,3	33,7	32,1	31,8	31,3	30,1	29,7	29,3	28,5	27,4

¹⁾ bei Raumtemperatur von -10 °C bis +50 °C zulässig
²⁾ above 300°C intercrystalline corrosion occurs
³⁾ Intermediate values determined by linear interpolation

Pressure and Temperature Table according to DIN EN 1092-1 - Material: 13CrMo4-5; G17CrMo5-5														
PN	max. pressure (PS) in bar at temperature in °C ¹⁾													
	120 ²⁾	150	200	240 ²⁾	250	260 ²⁾	290 ²⁾	300	315 ²⁾	350	400	450	500	550
63	63	63	63	63	63	63	63	63	62,1	60,0	56,7	53,1	41,1	14,7
100	100	100	100	100	100	100	100	100	98,5	95,2	90	84,2	65,2	23,3
160	160	160	160	160	160	160	160	160	157,6	152,3	144	134,8	104,3	37,3

¹⁾ applicable down to -10 °C
²⁾ Intermediate values determined by linear interpolation

Pressure and Temperature Table according to DIN EN 1092-3 - Material: CuSn5Zn5Pb5-C / CC491K ²⁾											
PN	max. pressure (PS) in bar at temperature in °C										
	120 ¹⁾	140 ³⁾	150	180	190 ³⁾	200	220	240 ³⁾	250	260	
10	10,0	10,0	10,0	10,0	9,2	8,5	7,0	5,6	5,0	4,0	
16	16,0	16,0	16,0	16,0	14,7	13,5	11,3	9,1	8,0	7,0	
25	25,0	25,0	25,0	25,0	23,1	21,2	17,5	13,9	12,2	10,5	
40	40,0	39,0	38,5	34,0	32,0	30,0	25,5	21,5	19,5	17,5	

¹⁾ admissible from -10°C to +120°C
²⁾ formerly G-CuSn5Zn5Pb / 2.1096.1 (Rg5)
³⁾ Intermediate values determined by linear interpolation

Material used according to Baelz type number for the most important pressurized components			
Baelz Type	Nominal Pressure PN	Material	Material Number
185	16 - 40	X20Cr13	1.4021
192	16 / 25	GJS-400-18-LT P250GH P235GH	5.3103 1.0460 1.0345
192	40	GP240GH GJS-400-18-LT P250GH P235GH	1.0619 5.3103 1.0460 1.0345
334	16 / 25	CuSn5Zn5Pb5-C (Rg 5) CuZn30	CC491K CW505L
335	16 / 25	CuSn5Zn5Pb5-C (Rg 5)	CC491K
340	16 / 25	GJS-400-18-LT P250GH	5.3103 1.0460
340	40	GP240GH P250GH	1.0619 1.0460
342	16 / 25	GJS-400-18-LT	5.3103
342	40	GP240GH	1.0619
344	16 - 40	GX5CrNiMo19-11-2	1.4408
346-22	16 / 25	GJS-400-18-LT P250GH	5.3103 1.0460
346-22	40	GP240GH P250GH	1.0619 1.0460
347	16 / 25	GJS-400-18-LT	5.3103
347	40	GP240GH	1.0619
353	16 - 40	X6CrNiMoTi17-12-2	1.4571
354	16 - 40	GX5CrNiMo19-11-2 X6CrNiMoTi17-12-2	1.4408 1.4571
356-VA	16 - 40	X6CrNiMoTi17-12-2	1.4571
356	16 - 40	P250GH	1.0460
358-K	63 / 100 / 160	13CrMo4-5 G17CrMo5-5	1.7335 1.7357
359-K	63 / 100 / 160	GP240GH P250GH	1.0619 1.0460
360	40	GP240GH X6CrNiMoTi17-12-2	1.0619 1.4571
471	16 / 25	CuSn5Zn5Pb5-C (Rg 5)	CC491K
472	16	CuSn5Zn5Pb2-C (Rg)	CC491K
474-RT	16	CuZn39Pb1Al-C	CC754S
474-MMSV	16	CuZn39Pb1Al-C CuZn40	CC754S CW509L
475	16	CuSn5Zn5Pb5-C (Rg 5)	CC491K
480	16 / 25	GJS-400-18-LT	5.3103
480	40	GP240GH P250GH P235GH	1.0619 1.0460 1.0345
585	16	GJS-400-18-LT	5.3103
590	16 / 25	GJS-400-18-LT P250GH P235GH	5.3103 1.0460 1.0345
590	40	GP240GH P250GH P235GH	1.0619 1.0460 1.0345
591	16 / 25	GJS-400-18-LT P250GH P235GH	5.3103 1.0460 1.0345
591	40	GP240GH P250GH P235GH	1.0619 1.0460 1.0345
650	16 / 25	GJS-400-18-LT P250GH	5.3103 1.0460

Within the context of European harmonization, DIN standards are successively being revised. The most important changes are listed in the tables below.

Connection Dimensions		
	currently	formerly
Flanges	DIN EN 1092-1 DIN EN 1092-2	DIN 2500 ff.
Welded ends	DIN EN 12627	DIN 3239, part 1
Welded sleeves	DIN EN 12760	DIN 3239, part 2

Face-to-face Dimensions								
	Flanges				Welded ends			
	currently		formerly		currently		formerly	
	Standard	Series	Standard	Series	Standard	Series	Standard	Series
Valves	DIN EN 558	1 2 14 8	DIN 3202 part 1	F1 F2 F4 F32	EN 12982	64 65	DIN 3202 part 2	S2 S3
Gate valves	DIN EN 558	15 26	DIN 3202 part 1	F5 F7	EN 12982	15 26	DIN 3202 part 2	S8 S9
Butterfly valves	DIN EN 558	20	DIN 3202 part 3	K1	-	-	-	-

The following EC directives are complied with, within their respective scope:		
2014/68/EU	Pressure Equipment Directive	formerly: 97/23/EG
2014/35/EU	Low Voltage Directive	formerly: 2006/95/EG
2014/30/EU	Electromagnetic Compatibility	formerly: 89/336/EWG
2006/42/EG	Machinery Directive	formerly: 98/37/EG
2014/34/EU	ATEX Directive	formerly: 94/9/EG

The following standards apply for our products:		
Industrial process control valves	DIN EN 1349	formerly: DIN IEC 60534-4
Marking of industrial valves	DIN EN 19	
Face-to-face dimensions of valves	DIN EN 558	
Definition of components of valves	DIN EN 736	
Selection of materials	EN 1503	
Flanges and their joints	DIN EN 1092	
Screws and nuts	DIN EN 1515-1	formerly: DIN 2507
Gaskets for flanges	DIN EN 1514	formerly: DIN 2690
Inspection documents for materials	DIN EN 10204	formerly: DIN 50049
Resistance and leakage tests	DIN EN 12266-1	formerly: DIN 3230
Inspection documents for materials	DIN EN 60534-2-3	identical to: IEC 60534-2-3
Industrial valves–Shell design strength	DIN EN 12516-2	formerly: DIN 3840
Industrial process control valves - Noise considerations	DIN EN 60534-8-4	formerly:VDMA 24422
Pressure equipment	AD 2000 guidelines	
Pressure vessels - Equipment shells	TRB 801 Nr. 45*	
Pressure vessels	DIN EN 13445	
Pipework systems	DIN EN 13480	
Heating plants for district heating	DIN 4747-1	
Water heating systems	DIN EN 12828	formerly: DIN 4751
Shell boilers	DIN EN 12953-6	formerly: DIN 4752
Systems for the production of hot water	DIN 4753-1	
Temperature monitors and temperature limiters for heat generating systems	DIN EN 14597	formerly: DIN 32730 DIN 3440
Safety of machinery	DIN EN ISO 12100	formerly: DIN EN 292
Electrical equipment of machines	DIN EN 60204-1	
Electromagnetic Compatibility (EMC) –Generic emission standard	DIN EN 61000-6-3 DIN EN 61000-6-4	formerly: DIN EN 50081-1 DIN EN 50081-2
Electromagnetic Compatibility (EMC) –Generic immunity standard	DIN EN 61000-6-1 DIN EN 61000-6-2	formerly: DIN EN 50082-1 DIN EN 50082-2
Safety requirements for electrical equipment for measurement, control and laboratory use	DIN EN 61010-1	
Automatic electrical controls for household and similar use – Particular requirements for temperature sensing controls	DIN EN IEC 60730-2-9	
Automatic electrical controls for household and similar use – Particular requirements for electric actuators	DIN EN IEC 60730-2-14	

* Withdrawn. Can, however, be applied unless otherwise specified in the BetrSichV and the TRBS.

Materials						
currently			formerly			ASTM equivalent
Code	Number	Standard	Code	Number	Standard	Standard / Code
EN-GJL-250	5.1301	DIN EN 1561	GG-25	0.6025	DIN 1691	A 48-40B
EN-GJS-400-15	5.3106	DIN EN 1563	GGG-40	0.7040	DIN 1693-1	A 536-60-40-18
EN-GJS-400-18-LT	5.3103	DIN EN 1563	GGG-40.3	0.7043	DIN 1693-1	-
P235GH	1.0345	DIN EN 10216-2	St 35.8	1.0305	DIN 17175	A 414 C
P250GH	1.0460	DIN EN 10273 DIN EN 10222-2	C 22.8	1.0460	DIN 17243	A 105
P265GH	1.0425	DIN EN 10028-2	H II	1.0425	DIN 17155	A 285 C
P235TR1	1.0254	DIN EN 10216-1	St 37.0	1.0254	DIN 1626	A 519 1020
P235TR2	1.0255	DIN EN 10216-1	St 37.4	1.0255	DIN 1628	A 381 K03013
16Mo3+NT	1.5415	DIN EN 10273 DIN EN 10222-2	15Mo3	1.5415	DIN 17243	A 182 F1
13CrMo4-5	1.7335	DIN EN 10273 DIN EN 10222-2	13CrMo44	1.7335	DIN 17243	A 182 F11
X20Cr13	1.4021	DIN EN 10088-1	X20Cr13	1.4021	DIN 17440	AISI 420
X3CrNiMo13-4	1.4313	DIN EN 10088-1	X4CrNi134	1.4313	SEW 400	A 182 F6NM
X5CrNi18-10	1.4301	DIN EN 10088-1	X5CrNi1810	1.4301	DIN 17440	AISI 304
X6CrNiTi18-10	1.4541	DIN EN 10088-1	X6CrNiTi1810	1.4541	DIN 17440	AISI 321
X6CrNiMoTi17-12-2	1.4571	DIN EN 10088-1	X6CrNiMoTi17122	1.4571	DIN 17440	A 182 F316 A 276 316TI
X10CrNi18-8	1.4310	DIN EN 10088-1	X12CrNi177	1.4310	DIN 17224	AISI 301
X14CrMoS17	1.4104	DIN EN 10088-1	X12CrMoS17	1.4104	DIN 17440	AISI 430F
GP240GH	1.0619	DIN EN 10213	GS-C25	1.0619	DIN 17245	A 216 WCB
G17CrMo5-5	1.7357	DIN EN 10213	GS-17CrMo55	1.7357	DIN 17245	A 217 WC6
GX5CrNi19-10	1.4308	DIN EN 10213	G-X6CrNi189	1.4308	DIN 17445	A 351 CF8
GX5CrNiMo19-11-2	1.4408	DIN EN 10213	G-X6CrNiMo1810	1.4408	DIN 17445	A 351 CF8M
S235JRG2	1.0038	DIN EN 10025-2	RSt 37-2	1.0038	DIN 17100	A 283 B+C A 570 36
CuSn5Zn5Pb5-C	CC491K	DIN EN 1982	G-CuSn5ZnPb	2.1096.01	DIN 1705	B 505 C83600
CuZn39Pb1Al-C	CC754S	DIN EN 1982	GK-CuZn37Pb	2.0340.02	DIN 1709	-



W. Baelz & Sohn GmbH & Co.

Koepffstraße 5
74076 Heilbronn
Deutschland
Tel.: +49 7131 1500-0
mail@baelz.de
www.baelz.de

Baelz GmbH

Wildpretmarkt 2-4
1010 Wien
Österreich
Tel.: +43 664 5172626
wien@baelz.at
www.baelz.de

Baelz Automatic SARL

16, av. des Morillons
95146 Garges-lès-Gonesse
France
Tel.: +33 1 34 45 00 70
nousecrite@baelz.fr
www.baelz.fr

Baelz Heat Automation Equipments (Beijing) Co., Ltd.

Huateng Tower Unit 2008
Jia 302 3rd Area of Jinsong Chaoyang District
100021 Beijing
China
china@baelz.de
Tel +86 10 872160-08

Baelz North America LLC.

4875 Deen Road
Marietta, Georgia - 30066
USA
Tel.: +1 844 2235962
sales@baelzna.com
www.baelzna.com